

VOL. 5 ELEVATOR PRODUCTS CATALOG

ADA TELEPHONES ALARM BELLS BARRICADES BATTERIES BRAILLE TAGS CABLE CLIMBERS CABLE OILERS
CAPACITORS CAR LANTERNS CAR STATIONS CAR TOP INSPECTION STATIONS CARBON BRUSHES CERTIFICATE
FRAMES COMPENSATING CABLE CONTACT KITS CONTROL RELAYS DAMPENING DEVICES DIGITAL MULTIMETERS
DOOR EDGES DOOR GIBS DOOR KEYS DOOR MOTORS DOOR OPERATOR REPAIR PARTS DOOR OPERATORS DRIP
RINGS DUCT ELEVATOR CABLES EMERGENCY LIGHTING ESCALATOR BRUSH GUIDES ESCALATOR ROLLERS FALSE
CARS FANS FLOOR PROTECTION FUSES GFCI DEVICES GREASES GROOVED COUPLINGS GUIDE SHOES GUIDE
WHEEL ROLLERS HALL STATIONS HOISTING EQUIPMENT HOISTWAY CABLE HYDRAULIC INSTALLATION TOOLS
INSPECTION STATIONS ISOLATION COUPLINGS KELLEMS GRIPS KEY KEEPERS LADDERS LEDS LIGHT BULBS
LIGHTING FIXTURES LIMIT SWITCHES LOCKOUT/TAGOUT DEVICES LUBRICANTS MOTOR GENERATOR FILTERS
MOTOR STARTERS MOTORS MUFFLERS MULTIMETERS OIL TRANSFER PUMPS OPEN RELAYS PACKINGS PENDANT
STATIONS PHASE MONITORS PIANO WIRE PIT LADDERS PIT PADS PIT SWITCHES PORTABLE FILTRATION SYSTEMS
POWER SUPPLIES POWER TOOLS PRESSURE GAUGES PUSHBUTTONS RAIL BRACKETS RAIL SHIMS RELAY BASES
RELAYS RESISTORS ROLLER GUIDES ROLLERS SAFETY EQUIPMENT SAW BLADES SCAVENGER PUMPS SELECTOR
TAPES SHACKLES SIGNS SOLID STATE STARTERS SUBMERSIBLE MOTORS TACH GENERATORS TANK HEATERS
TEST WEIGHT CARTS TIMERS TOOLS TRAVELING CABLE VALVES VICTAULIC FITTINGS WEDGE SOCKETS WIRE
MESH CABLE GRIPS WIRE ROPE WIREWAY ADA TELEPHONES ALARM BELLS BARRICADES BATTERIES BRAILLE
TAGS CABLE CLIMBERS CABLE OILERS CAPACITORS CAR LANTERNS CAR STATIONS CAR TOP INSPECTION STATIONS
CARBON BRUSHES CERTIFICATE FRAMES COMPENSATING CABLE CONTACT KITS CONTROL RELAYS DAMPENING
DEVICES DIGITAL MULTIMETERS DOOR EDGES DOOR GIBS DOOR KEYS DOOR MOTORS DOOR OPERATOR REPAIR
PARTS DOOR OPERATORS DRIP RINGS DUCT ELEVATOR CABLES EMERGENCY LIGHTING ESCALATOR BRUSH GUIDES
ESCALATOR ROLLERS FALSE CARS FANS FLOOR PROTECTION FUSES GFCI DEVICES GREASES GROOVED COUPLINGS
GUIDE SHOES GUIDE WHEEL ROLLERS HALL STATIONS HOISTING EQUIPMENT HOISTWAY CABLE HYDRAULIC
INSTALLATION TOOLS INSPECTION STATIONS ISOLATION COUPLINGS KELLEMS GRIPS KEY KEEPERS LADDERS
LEDS LIGHT BULBS LIGHTING FIXTURES LIMIT SWITCHES TAGOUT/LOCKOUT DEVICES LUBRICANTS MOTOR
GENERATOR FILTERS MOTOR STARTERS MOTORS MUFFLERS MULTIMETERS OIL TRANSFER PUMPS OPEN RELAYS
PACKINGS PENDANT STATIONS PHASE MONITORS PIANO WIRE PIT LADDERS PIT PADS PIT SWITCHES PORTABLE
FILTRATION SYSTEMS POWER SUPPLIES POWER TOOLS PRESSURE GAUGES PUSHBUTTONS RAIL BRACKETS
RAIL SHIMS RELAY BASES RELAYS RESISTORS ROLLER GUIDES ROLLERS
SAFETY EQUIPMENT SAW BLADES SCAVENGER PUMPS SELECTOR TAPES
SHACKLES SIGNS SOLID STATE STARTERS SUBMERSIBLE MOTORS TACH GEN-
ERATORS TANK HEATERS TEST WEIGHT CARTS TIMERS TOOLS TRAVELING



CED ELEVATOR & ELECTRICAL



© 2010 CED Elevator Supply Division. All rights reserved.
No part of this catalog may be reproduced without the permission of CED.

Consolidated Electrical Distributors (CED) is a multi-billion-dollar family-owned international wholesale distributor, founded in 1957. We are known for being the low-cost provider in the markets we enter, as well as providing custom products and services to meet the needs of our customers in these specific markets.

CED Elevator & Electrical was formed in May 1999, by joining CED-Long Beach in California and All-Phase Electric Supply in Tucson, AZ and South Windsor, CT. Later, as demand for our service increased, Grand Prairie, TX was opened in 2012. In 2017, CED Elevator & Electrical opened our newest location in Columbia, Maryland to service the Mid-Atlantic.

Our initial task was to investigate, evaluate and implement the “best practices” of each location. We currently service the modernization, construction, OEM, and the service and repair segments of the elevator marketplace. A list of some of our “value added” services is available on request. Our vision is to offer a national source to the elevator industry of premier parts and services at consistent and competitive prices.

After three years of meticulous research by our knowledgeable staff, we have assembled, under one cover, over 10,000 items you want and need every day. We have formed strategic relationships with premier vendors of choice to bring you our competitive advantage – “ONE STOP SHOPPING” for all your elevator parts needs.

When calling any of our four distribution centers, you have our assurances that we will work tirelessly everyday to earn your business and will strive to continuously bring to the elevator marketplace new and innovative products as they become available.

— The Staff of
CED Elevator & Electrical

CUSTOM PRODUCTS..... & VALUE-ADDED SERVICES

↓
**And a range of
Value-Added Services
including...**

Kitting
Connectorization
Custom Assemblies
Fullfillment Services
Logistics Management
Value Engineering

Call for Details...
(866) CED-ELEV • (866) 233-3538
www.cedelevator.com

↓
***CED offers
Custom Products
to suit most new and
existing applications
including...***

Jacks
Pump Units
Cab & Interiors
Entrances & Doors
Platform & Slings
Handrails
Pit Ladders
Communication / Intercom Systems
Cable Assembly / Harnesses
Cab Pads
Acrylic Signs
Braille Tags
Top of Car Handrails

TABLE OF CONTENTS

Batteries	1	Mechanical Piping Systems	17
Cable & Installation Hardware	2	Motors	18
Contactors, Starters, Relays & Timers ..	3	Motor Control & Distribution	19
Door Operators & Parts/GAL Replacement		Motor Generator Filters	20
Parts & Components	4	Mufflers & Couplings	21
Electrical & Industrial Products	5	Packings & Seals	22
Fans & Heaters	6	Peelle Parts Guide	23
Controllers, Fixtures, Doors, Edges		Rail Installation & Alignment	24
& Pump Units	7	Safety Equipment	25
Fuses	8	Scavenger Pumps	26
General Purpose	9	Signs & Braille Tags	27
Hoisting Equipment & Supplies	10	Telephones & Cabinets	28
Hydraulic Installation Tools	11	Test & Measuring Equipment	29
Inspection, Fire & Signaling Devices ..	12	Tools	30
Keys & Key Keepers	13	Wire & Wire Rope Products	31
Lamps & LEDs	14	Wireway & Fittings	32
Lighting Fixtures	15	Data Forms & Order Forms	33
Lubricants & Functional Fluids	16	Index	34



BATTERIES

1

In this Section

Sealed Lead-Acid Batteries	1.2
Alkaline Batteries	1.3
Rechargeable Alkaline Batteries	1.3
Battery Cross Reference	1.4

Commonly Used Elevator Batteries

Sealed Lead-Acid Batteries

ZEUS Catalog Number	Description	Power-Sonic Catalog Number	ZEUS Catalog Number	Description	Power-Sonic Catalog Number
PC1.3-6F1	6V 1.3AH BATTERY	PS-612	PC7.2-12F2	12V 7.2AH BATTERY	PS-1270
PC3.4-6F1	6V 3.4AH BATTERY	PS-630	PC9-12S F1	12V 9AH BATTERY	PS-1290
PC4.5-6F1	6V 4.5AH BATTERY	PS-640	PC9-12S F2	12V 9AH BATTERY	PS-1290
PC4.5-6XB	F1 6V 4.5AH BATTERY	PS-640	PC12-12F2	12V 12AH BATTERY	PS-12120
PC7-6F1	6V 7AH BATTERY	PS-670	PC18-12NB	12V 18AH BATTERY	PS-12180
PC12-6F1	6V 12AH BATTERY	PS-6100	PC22-12NB	12V 22AH BATTERY	PS-12200
PC12-6XBF1	6V 12AH BATTERY	PS-6100	PC26-12NB	12V 26AH BATTERY	PS-12260
PC12-6TFP	6V 12AH BATTERY	PS-6120FP	PC33-12NB	12V 33AH BATTERY	PS-12330
PC1.3-12F1	12V 1.3AH BATTERY	PS-1212	PC40-12NB	12V 40AH BATTERY	PS-12400
PC3.4-12F1	12V 3.4AH BATTERY	PS-1230	PC55-12NB	12V 55AH BATTERY	PS-12550
PC5-12F1	12V 5AH BATTERY	PS-1250	PC70-12NB	12V 70AH BATTERY	PS-12750
PC7-12F1	12V 7AH BATTERY	PS-1270	PC100-12NB	12V 100AH BATTERY	PS-121000
PC7-12F2	12V 7AH BATTERY	PS-1270			

*Additional sizes available upon request.

Battery Packs & Button Cells

Part Number	Nominal Voltage	Nominal Capacity Ah	Length	Height	Description	Terminals
D/5	4.8	4.0	3.75	2.5	(5) D cells stacked 2 on 3	wire leads
21EL005	4.8	2.2	5.75	1.25 dia	(4) 1/2 D cells stacked end to end	wire leads
JBS EA113AA541H0	6	150 mAh	3.42	.68 dia	(5) 1/3 AA cells stacked end to end	solder tabs
BR23AT2SP	3	1200 mAh	1.319	.669 dia	Panasonic Lithium	solder tabs
357	1.55	155 mAh			11.6mm dia x 5.42mm Button cell	n/a
CR2430	3	270 mAh			24mm dia x 3.0mm Button cell	n/a
CR123A	3	1550 mAh	1.35	.067 dia	Lithium	button top
BR23AT2SP-WLP	3	1200 mAh	17mm	33.5mm	Lithium	solder tabs
CR2032	3	240 mAh	.697	.126	Coin cell	n/a

Commercial Part Number	Also Avail.	AMP Hours	Voltage	Dimensions:
0802-0016	10	6	6	5.38 x 3.50 x 2.94 / 132 x 89 x 73
0819-0013	2.5	6	6	4.38 x 1.75 x 2.75 / 110 x 45 x 69
RB640	4.5	6	6	2.76 x 1.86 x 4.25 / 70 x 47 x 108
NP7-6	7	6	6	5.95 x 1.30 x 3.94 / 151 x 33 x 100
0859-0024	8	6	6	5.38 x 2.06 x 3.94 / 135 x 52 x 100
NP8.5-6	8	6	6	3.86 x 2.20 x 4.65 / 98 x 56 x 118
RB6100	10	6	6	5.95 x 2.00 x 3.86 / 151 x 51 x 98
NP12-6	12	6	6	5.95 x 1.97 x 3.98 / 151 x 50 x 101
NP12-6P	12	6	6	5.95 x 1.97 x 3.98 / 151 x 50 x 101
NP2.3-12	2.3	12	12	7.01 x 1.38 x 2.64 / 178 x 35 x 67
NP2.6-12	2.6	12	12	5.28 x 2.64 x 2.60 / 134 x 67 x 66
PS1229	2.9	12	12	7.00 x 1.38 x 2.60 / 178 x 35 x 66
NP4-12	4	12	12	3.54 x 2.76 x 4.21 / 90 x 70 x 107
NP7-12	7	12	12	5.95 x 2.56 x 3.94 / 151 x 65 x 100
NP12-12T	12	12	12	5.94 x 2.56 x 3.86 / 151 x 65 x 98
GA31462001	14	12	12	5.94 x 2.56 x 3.86 / 151 x 65 x 98
NP24-12T	24	12	12	6.54 x 6.89 x 4.92 / 166 x 175 x 125
NP24-12B	24	12	12	6.54 x 6.89 x 4.92 / 166 x 175 x 125

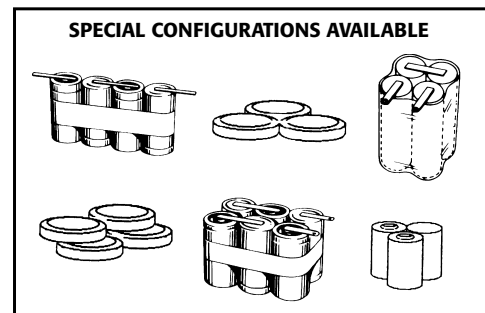

Questions? Answers at...
(866) CED-ELEV • (866) 233-3538
www.cedlevator.com

Alkaline Batteries

Alkaline Batteries

Here is a new generation of alkaline batteries that protect the environment by having a mercury-free formula. Reformulated for better performance, these batteries are reliable and safe to use, because they are guaranteed not to leak. No other battery in the industry is more powerful.

Part Number	Description
AL-D	Size D, 6-pack
AL-C	Size C, 6-pack
AL-AA	Size AA, 4-pack
AL-AAA	Size AAA, 4-pack
AL-9V	9-volt, 6-pack



RAY-O-VAC

Rechargeable Alkaline

Part Number	Description
7132	Size D Renewal
7142	Size C Renewal
7154	Size AA Renewal
7244	Size AAA Renewal
PS1	Renewal 4-Pos. Charger, AA or AAA Batteries
PS2	Renewal Kit-PS3 w/ (4) D, (2) C, (4) AAA, (4) AA Batteries

Questions? Answers at...
(866) CED-ELEV • (866) 233-3538
www.cedelevator.com

Battery Cross Reference

Battery Equivalents Shown By Row / Items in Bold are Stock Supported Drop Ship Items

Powercell	Powersonic	CSB	Panasonic	Energys (old Yuasa)	Interstate	GS/ Portalac	Kung Long	MK East Penn	Haze	Universal	Other	Union	BB Battery
PC1.3-6	PS-612	GP613	LC-R01R3P	NP1.2-6		PE6V1.2	WP1.2-6	ES1.2-6	HZS6-1.3	UB613	RB612	MX-06012	BP1.2-6
PC3.4-6F1	PS-630	GP633	LC-R063R4P	NP3-6		PE6V3A	WP3.4-6			UB634	LS16V30, RB630		
PC4-6	PS-640	GP645 NP5-6	LC-RB064P	NP4-6, NP4.5-6, NP5-6		PE6-4	WP4-6, WP4.5-6	ES4-6	HZS6-5	UB645	RB640	MX-06040	BP4-6, BP4.5-6
PC7-6F1	PS-670	GP672	LC-R067R2P	NP7-6		PE6V6.5	WP7-6	ES7-6	HZS6-7.2	UB670	RB670	MX-06070	BP8-6H
PC8.5-6	PS-682			NP8.5-6		PE6V8	WP13-6			UB685	RB682		BP8-6V
PC12-6F1		GP6120	LC-R0612P1	NP12-6 , NP10-6	SLA0955	PE6V10, PE6V12	WP12-6	ES10-6, ES12-6	HZS6-10, HZS6-12	UB6120	RB6100	MC-06100, MX-06120	BP10-6, BP12-6
PC12-6TFP	PS-6120	GH6120					WP13-6		HZS6-14	UB6120	RB6120, RB695		BP13-6WH
PC1.3-12	PS-1212	GP1213	LC-R121R3PU	NP1.2-12		PE12V1.2	WP1.2-12	ES1.2-12	HZS12-1.3	UB1213	RB1212	MX-12012	BP1.2-12
PC2.2-12	PS-1220	GP1222	LC-R122R2P	NP2.3-12		PE12V1.9	WP1.9-12	ES1.9-12	HZS12-2.2	UB1222	RB1220	MX-12020	BP2.3-12
	PS-1223	GH1223S	LC-SA122R3EU	NP2.3-12			WP2.3-12			UB1223A	RB1223		
	PS-1229					PE12V2.7	WP2.9-12T		HZS12-2.9	UB1229T	RB1229		BP3-12
				NP2.6-12									
PC3.4-12F1	PS-1230		LC-R123R4P					ES3-12	HZS12-3.3	UB1234	RB1230		BP3.6-12
PC4.5-12	PS-1242	GP1245	LC-RB124P	NP4-12	SLA1050, SLA1055	PX12050	WP4-12	ES4-12	HZS12-5	UB1250	RB1242	MX-12040	BP4.5-12
	PS-1250F2	GP1250	LC-R125P	NPH5-12		PE12V5	WP5-12	ES5-12		UB1250	RB1252		BP5-12
PC7-12F1	PS-1270	GP1272	LC-R127R2P	NP7-12	SLA1075, SLA1079	PE12V7, PX12072	WP7-12 WP7.2-12	ES7-12	HZS12-7.5	UB1280	RB1270	MX-12070	BP7-12 BP7.5-12, BP8-12
PC9-12S	PS1282L					PE12V9, PX12090	WP8-12		HZS12-9	UB1290			HR9-12
PC12-12F2	PS-12120	GP12120	LC-RA1212P	NP12-12T	SLA1104, SLA1105	PE12V12	WP12-12	ES12-12	HZS12-12	UB12120	RB12120	MX-12120	BP12-12
GA31462001											CF12V14L, CFM12V125L		
PC17-12	PS-12180	GP12170	LC-RD1217P	NP18-12	SLA1116	PE12V15, PE12V17	WP17-12	ES17-12	HZB12-18, HZS12-15F	UB12180	RB12180-F2	MX-12170	BP17-12
PC26-12NB	PS-12260	GP12260		NP24-12B	SLA1146	PE12V24A, PE12-23	WP24-12	ES26-12	HZS12-26F	UB12260	RB12260-NB	MX-12240	BP26-12
PC33-12NB	PS-12330	GP12340	LC-LA1233P	NP33-12	SLA1156		U1-34	U-1/SLA	HZB12-33, HZS12-35F	UB12350	RB12330	MX-12310	BP33-12F
	PS12400	GP12400	LC-X1242P	NP38-12		PE12V40A, PE12-40	WP38-12, U1-38	ES40-12	HZB12-44	UB12400	RB12400	MX-12400	BP40-12
PC55-12NB	PS-12550			NP55-12	SLA1165		WP50-12		HZB12-55	UB12550	RB12550		

Questions? Answers at...
(866) CED-ELEV • (866) 233-3538
www.cedlevator.com

CABLE & INSTALLATION HARDWARE

2

In this Section

Product Specifications

Traveling Cable	
Type ETT-JC (Jute Core)	2.2-3
Type ETT-SC (Steel Center Core)	2.4-5
Type ETT-C (Communications)	2.6-7
Shielded Pairs	2.7
Hoistway Cable	
Stranded Conductor	2.8-9
Stationary Wiring Shielded Pairs	2.10
Compensating Cable	2.11

Cable Technical Information

Shielded Pairs	2.7
Coaxial	2.12
Steel Center Core	2.12
Color Code Chart	2.12
Metric Cross-Reference	2.12

Accessories

Compensating Cable Installation Kits & Damping Devices.	2.13
Cable Hanging Support Bracket	2.13
Kellems Grips, Tinned Bronze	2.14
Kellems Grips, Stainless Steel	2.15

Safety Devices & Tools

Square Mesh Safety Cloth	2.16
Hoistway Guard Systems	2.16
Cable & Wire Cutting Tools.	2.17

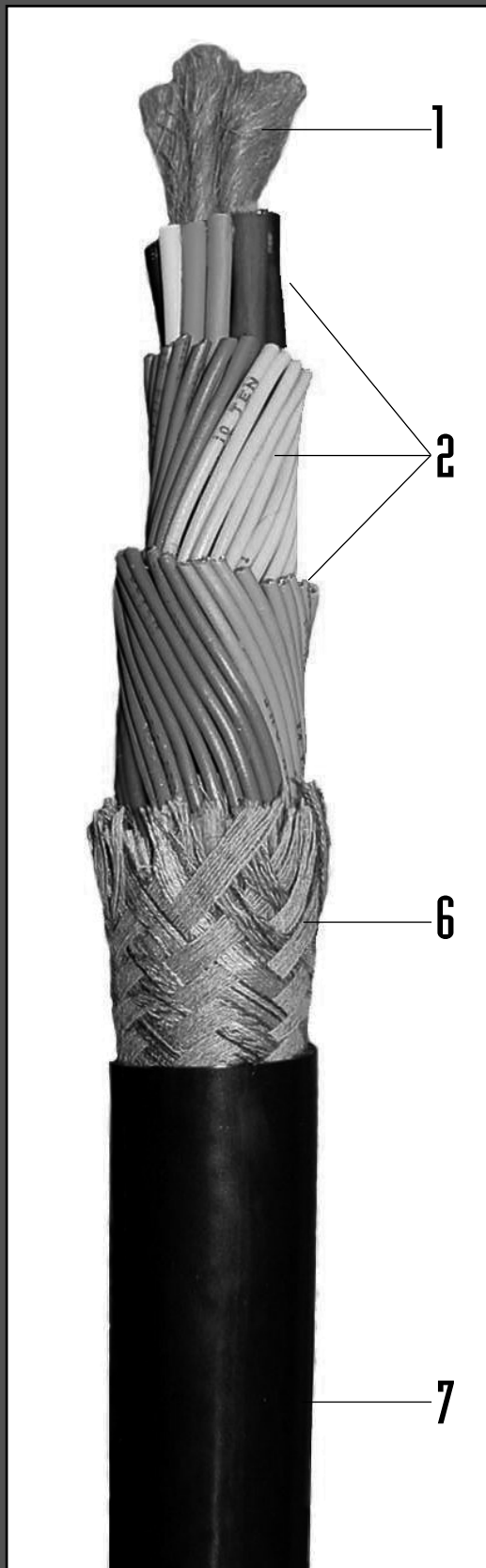

Elevator Traveling Cable Type ETT-JC (Jute Core)

Type ETT-JC (Jute Center Core) Traveling cables are designed for installations in elevators, dumbwaiters, personnel and material hoists. The cables are used for suspended lengths of under 200 feet (61 meters) as specified by the NEC, UL, CSA, and Canadian Electrical Codes.

Construction

1. Center Jute Core

Fibrous-plyed jute center core, insulated conductors are cabled around.

2. Insulated Conductors

Soft-annealed, bunched stranded, bare copper per ASTM Standards B3 and B174. The conductors are insulated with flame retardant 60°C polyvinyl chloride and are rated at 300 volts in accordance with the requirements of UL 62, CSA C22.2 No. 49 and the appropriate articles of the NEC and Canadian Electrical codes. Each conductor is color and number-coded for easy identification.

3. Shielded Pairs (optional, not shown)

Two insulated No. 20 AWG soft-drawn bare copper conductors, PVC insulated, twisted with a bare drain wire. The laminated polyester and aluminum foil tape creates 100% shield coverage. The assembly has an overall colored PVC jacket and rated 300V.

4. Coaxial Cable (optional, not shown)

RG-6, 75 ohm and 300V rated coaxial cable.

5. Fillers (not shown)

Fibrous-plyed jute fillers to provide the cable a circular cross section, enhance torsion stability, and cushion the construction during flexing.

6. Braid

A tightly woven braid of cotton, rayon, or equivalent applied over the core to help maintain core shape, torsion balance and add mechanical strength.

7. Jacket

An overall jacket of polyvinyl chloride provides a smooth, flexible, abrasion-resistant covering complying with the flame test requirements UL 1581 and is CSA FT-1 flame rated.

Questions? Answers at...
(866) CED-ELEV • (866) 233-3538
www.cedlevator.com

Elevator Traveling Cable Type ETT-JC (Jute Core)

Specifications Type ETT-JC (Jute Core)

Part Number	Size and Number of Components			Outside Diameter		Weight	
	14 AWG (2.08mm ²)	18 AWG (.82mm ²)	20 AWG Shld Pair 2x(.51mm ²)	inches	mm	lbs./Mft	kg/km
TCJ0414	4			0.48	12.2	132	196
TCJ0418		4		0.34	8.4	69	103
TCJ0618SPL		6		0.43	10.9	96	143
TCJ1018		10		0.54	13.7	163	243
TCJ1618		16		0.64	16.3	219	326
TCJ2018		20		0.71	18	295	439
TCJ2418		24		0.73	18.5	304	452
TCJ3018		30		0.83	21	386	574
TCJ4018		40		0.92	23.4	475	707
TCJC27	3	20	2	0.92	31.2	707	1052
TCJC33SPL	3	22	4	1.23	31.2	707	1052
TCJC37	4	31	1	1.15	29.2	700	1042
TCJC38W	12	18	4	1.22	31	814	1211
TCJC45	4	39	1	0.99	25.1	639	951
TCJC45D	4	31	5	1.27	32.4	853	1269
TCJC51	4	45	1	1.20	30.5	757	1126
TCJC55D	4	41	5	1.39	35.3	917	1364
TCJC57	6	45	3	1.39	35.3	943	1403
TCJC59	4	49	3	1.27	32.2	912	1357
TCJC60	4	54	1	1.26	32.0	785	1168
TCJC66	4	56	3	1.33	33.8	945	1406
TCJC73	6	61	3	1.41	35.8	1076	1601
TCJC76		66	5	1.42	36.1	1017	1513
TCJC79SPL	7	64	4	1.45	36.8	1165	1734
TCJC86	4	76	3	1.49	35.3	1128	1678
TCJC96		86	5	1.42	36.2	1134	1687

The data herein is approximate and subject to normal manufacturing tolerances.
These specifications subject to change without notice.

(1) NEC Article 620-41 allows for unsupported lengths of up to 200 feet (61 meters) when travelling cables are suspended from the supports by means that automatically tighten around the cable when tension is increased.

- IDEAL LOOP IS 30X DIAMETER OF CABLE
- MINIMUM IS 25X DIAMETER OF CABLE
- IDEAL BEND/WRAP IS 15X DIAMETER

Questions? Answers at...
(866) CED-ELEV • (866) 233-3538
www.cedlevator.com

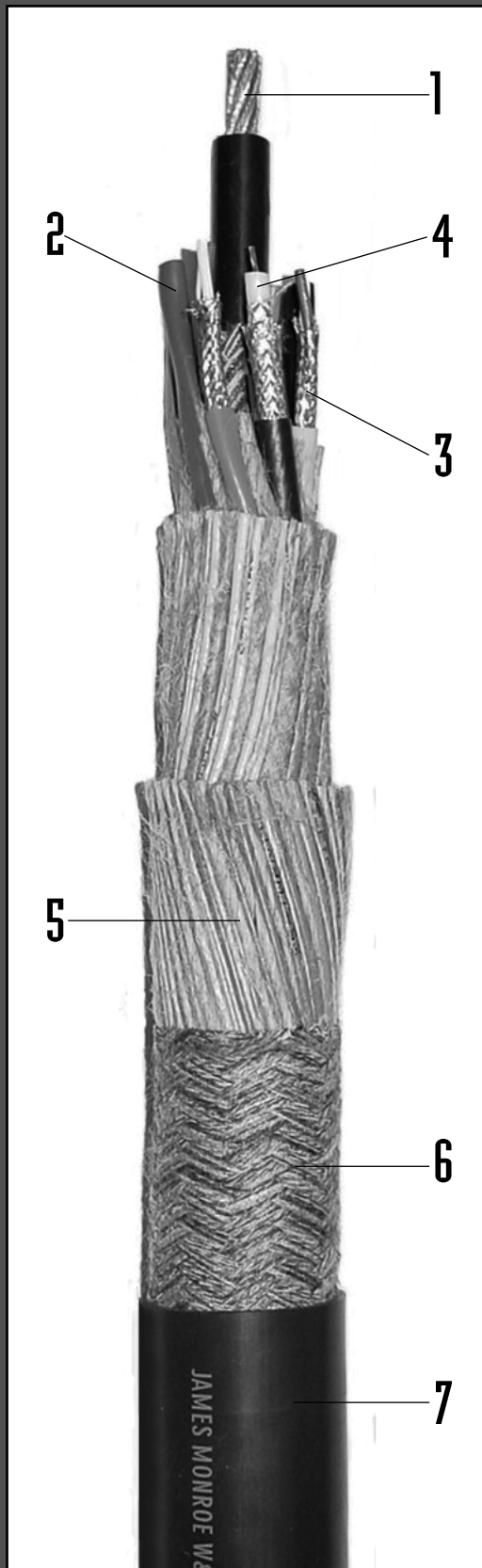

Elevator Traveling Cable

Type ETT-SC (Steel Center Core)

Type ETT-SC (Steel Center Core) Traveling cables are designed for installations in elevators, dumbwaiters, personnel, and material hoists. They are recommended for suspended lengths of over 200 feet (61 meters) as specified by the NEC and Canadian Electrical Codes.

Construction

1. Center Steel Support Cable

Flexible, performance rated, galvanized steel wire rope support strand, manufactured to Military Specification MIL-W-83420. The steel core has 60C flame-retardant polyvinyl chloride insulation and a reinforcing tightly woven braid of cotton or rayon.

2. Insulated Conductors

Soft-annealed, bunched stranded, bare copper per ASTM Standards B3 and B174. The conductors are insulated with flame retardant 60°C polyvinyl chloride and are rated at 300 volts in accordance with the requirements of UL 62, CSA C22.2 No. 49 and the appropriate articles of the NEC and Canadian Electrical codes. Each conductor is color and number-coded for easy identification.

3. Shielded Pairs (optional)

Two insulated No. 20 AWG soft-drawn bare copper conductors, PVC insulated, twisted with a bare drain wire. The laminated polyester and aluminum foil tape creates 100% shield coverage. The assembly has an overall colored PVC jacket and rated 300V.

4. Coaxial Cable (optional)

RG-6, 75 ohm and 300V rated coaxial cable.

5. Fillers

Fibrous-plyed jute fillers to provide the cable a circular cross-section, enhance torsion stability, and cushion the construction during flexing.

6. Braid

A tightly woven braid of cotton, rayon, or equivalent applied over the core to help maintain core shape, torsion balance and add mechanical strength.

7. Jacket

An overall jacket of polyvinyl chloride provides a smooth, flexible, abrasion-resistant covering complying with the flame test requirements UL 1581 and is CSA FT-1 flame rated.

Questions? Answers at...
 (866) CED-ELEV • (866) 233-3538
www.cedlevator.com

Elevator Traveling Cable Type ETT-SC (Steel Center Core)



Specifications Type ETT-SC (Steel Center Core)

Part Number	Size and Number of Components				Outside Diameter		Weight		Maximum Hanging Length		Steel Core Diameter	
	14 AWG (2.08mm ²)	18 AWG (.82mm ²)	20 AWG Shld Pair 2x(.51mm ²)	Coax 22 AWG (.36mm ²)	inches	mm	lbs./Mft	kg/km	feet	meters	inches	mm
TCS0414	4				0.56	14.4	182	271	900	274	3/32	2.4
TCS0814	8				0.68	17.3	300	446	900	274	1/8	3.2
TCS1514	15				0.91	23.1	493	734	900	274	1/8	3.2
TCS0618		6			0.49	12.4	124	185	900	274	3/32	2.4
TCS1018		10			0.56	14.2	195	290	861	262	3/32	2.4
TCS2018		20			0.71	18.2	314	467	804	245	3/32	2.4
TCS3018		30			0.82	20.8	436	649	900	274	1/8	3.2
TCS4018		40			0.92	23.4	513	763	874	266	1/8	3.2
TCS4518		45			0.93	23.6	576	857	900	274	1/8	3.2
TCS7518SPL		75			1.19	30.2	906	1348	773	236	1/8	3.2
TC SX05	3			2	1.09	27.7	549	817	900	274	5/32	4.0
TC SX14			6	2	1.10	27.9	583	868	900	274	5/32	4.0
TC SX18			8	2	1.38	25.4	483	719	900	274	5/32	4.0
TC SC20		14	3		0.94	24.0	438	652	612	187	3/32	2.4
TC SC27	4	21	1		0.95	24.1	529	787	900	274	5/32	4.0
TC SX28			13	2	1.34	34.0	903	1344	776	237	5/32	4.0
TC SX36	17		8	3	1.61	40.8	1419	2112	900	274	1/4	6.4
TC SC37	4	31	1		1.15	29.2	745	1109	900	274	5/32	4.0
TC SC44	14	24	3		1.33	33.8	929	1382	753	230	5/32	4.0
TC SC45D	4	31	5		1.27	32.3	931	1385	776	237	5/32	4.0
TC SC51	4	45	1		1.16	29.5	797	1240	878	268	5/32	4.0
TC SX53	4	45	1	2	1.25	31.7	754	1122	711	217	5/32	4.0
TC SC56	6	48	1		1.24	31.5	878	1307	826	252	5/32	4.0
TC SX57	4	40	6	1	1.50	38.1	1104	1643	612	187	5/32	4.0
TC SC59	4	49	3		1.22	31.0	666	991	791	241	5/32	4.0
TC SC60	7	27	13		1.54	39.1	1590	2366	900	274	1/4	6.4
TC SX61	7	27	13	1	1.64	41.6	1385	2061	900	274	1/4	6.4
TC SC64	22	30	6		1.61	40.9	1425	2120	900	274	1/4	6.4
TC SC71	6	61	2		1.42	36.1	1249	1859	614	187	5/32	4.0
TC SC74	20	38	8		1.50	38.1	1478	2199	491	150	5/32	4.0
TC SX750	20	38	8	1	1.54	39.1	1590	2366	900	274	1/4	6.4
TC SC75	4	69	1		1.34	34.0	1090	1622	663	202	5/32	4.0
TC SX77	4	69	1	2	1.48	37.6	1141	1698	532	162	5/32	4.0
TC SX77S	4	60	6	1	1.51	38.4	1392	2071	900	274	1/4	6.4
TC SC81	8	59	7		1.55	39.4	1340	1994	524	160	5/32	4.0
TC SC90	6	80	2		1.47	37.3	1355	2016	555	169	5/32	4.0
TC SC94	12	70	6		1.65	41.9	1613	2400	900	274	1/4	6.4
TC SC96		86	5		1.42	36.1	1213	1805	576	176	5/32	4.0
TC SX48HI	6	25	8	1	1.387	35.23	1000	1488	700	213	5/32	4.0
TC SX48LO	6	25	8	1	1.48	25.9	1132	1684	700	213	1/4	6.4
TC SC18FO (W/ 6 FIBER OPTICS)			6		1.12	36.1	428	637	900	274	5/32	4.0

The data herein is approximate and subject to normal manufacturing tolerances. These specifications subject to change without notice.

Questions? Answers at...
(866) CED-ELEV • (866) 233-3538
www.cedlevator.com

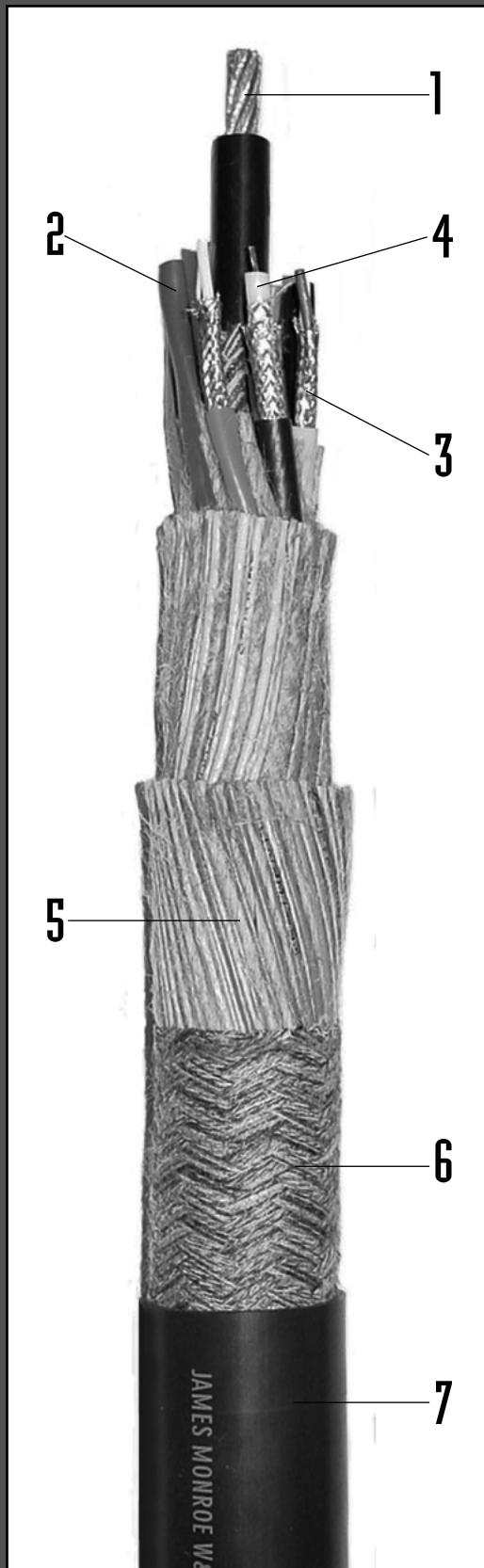

Elevator Traveling Cable Type ETT-C (Communications)

Type ETT-C (Communications Steel Center Core) Traveling cables are designed to complement existing or new communications cable installation and designed to track with other cables within the hoistway.

Construction

1. Center Steel Support Cable

Flexible, performance rated, galvanized steel wire rope support strand, manufactured to Military Specification MIL-W-83420. The steel core has polyvinyl chloride insulation and a reinforcing tightly woven braid of cotton.

2. Insulated Conductors (optional)

Soft-annealed, bunched stranded, bare copper per ASTM Standards B3 and B174. The conductors are insulated with flame retardant 60°C polyvinyl chloride and are rated at 300 volts in accordance with the requirements of UL 62, CSA C22.2 No. 49 and the appropriate articles of the NEC and Canadian Electrical codes. Each conductor is color- and number-coded for easy identification.

3. Shielded Pairs

Two insulated No. 20 AWG soft-drawn bare copper conductors, PVC insulated, twisted with a bare drain wire. The laminated polyester and aluminum foil tape creates 100% shield coverage. The assembly has an overall colored PVC jacket and rated 300V.

4. Coaxial Cable

RG-6, 75 ohm and 300V rated coaxial cable.

5. Fillers

Fibrous-plyed jute fillers to provide the cable a circular cross section, enhance torsion stability, and cushion the construction during flexing.

6. Braid

A tightly woven braid of cotton, rayon, or equivalent is applied over the core to help maintain core shape, torsion balance and add mechanical strength.

7. Jacket

An overall jacket of polyvinyl chloride provides a smooth, flexible, abrasion-resistant covering complying with the flame test requirements UL 1581 and is CSA FT-1 flame rated.

Questions? Answers at...
 (866) CED-ELEV • (866) 233-3538
www.cedlevator.com

Type ETT-C (Communications) Shielded Pairs

Specifications Type ETT-C (Communications)

Steel Core

Part Number	Size and Number of Components			Outside Diameter		Weight		Maximum Hanging Length		Steel Core Diameter	
	18 AWG Sh Pair (0.8mm ²)	20 AWG Sh Pair 2x(.51mm ²)	Coax 20 AWG (.36mm ²)	inches	mm	lbs./Mft	kg/km	feet	meters	inches	mm
TCSCC0220SH		2		0.77	19.6	200	298	900	274	3/32	2.4
TCSCC0420SH		4		0.81	20.5	324	482	900	274	1/8	3.2
TCSCC0620SH		6		0.83	21.2	382	521.1	900	274	1/8	3.2
TCSCC0820SH		8		1.02	25.9	547	814	900	274	5/32	4.0

The data herein is approximate and subject to normal manufacturing tolerances. These specifications subject to change without notice.

Shielded Pairs

Two insulated No. 20 AWG soft-annealed, bare copper conductors are twisted with an uninsulated drain wire. The laminated polyester and aluminum foil tape creates a 100% shield coverage. The assembly is covered with an overall colored PVC jacket.

Conductors: No. 20 AWG (10/.010") soft bare copper (.51 mm²–10/.254 mm)

Nominal D.C. Resistance: 10.4 ohms/1000 ft. (34.1 ohms/Km)

Nominal Capacitance:
 Between conductors: 40 pF/ft. (131 pF/m)
 Between 1 conductor and other conductor connected to shield: 68 pF/ft. (223 pF/m)

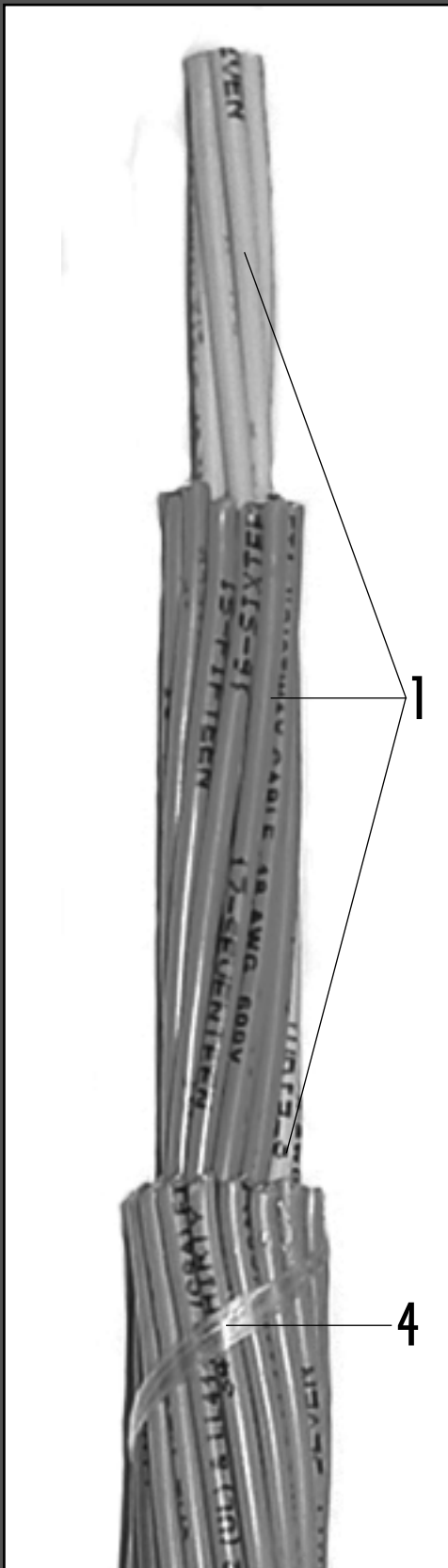

Elevator Hoistway Cable

600V

600V Hoistway cables permit faster and easier interconnection of hoistway control and signaling devices. The insulated, identified conductors, cabled together and bound with a strong spiral binder for quick removal for breakout connections.

Construction

1. Insulated Conductors

Soft-drawn, solid or stranded, bare copper per ASTM Standards B3 and B174. The conductors are insulated with flame retardant 60°C polyvinyl chloride and are rated at 600 volts in accordance with the requirements of UL 62, CSA C22.2 No. 49 and the appropriate articles of the NEC and Canadian Electrical codes. Each conductor is color and number-coded for easy identification.

2. Shielded Pairs (optional, not shown)

Two insulated No. 20 AWG soft-drawn bare copper conductors, PVC insulated, twisted with a bare drain wire. The laminated polyester and aluminum foil tape creates 100% shield coverage. The assembly has an overall colored PVC jacket and rated 300V.

3. Coaxial Cable (optional, not shown)

RG-6, 75 ohm and 300V rated coaxial cable.

4. Binder

High-strength synthetic fiber applied over the core to help maintain core shape, torsion balance and add mechanical strength.

5. Jacket (Optional, not shown)

An optional flame retardant polyvinyl chloride (PVC) jacket is available upon request and in accordance with UL 1084 and CSA FT-1.

Questions? Answers at...
 (866) CED-ELEV • (866) 233-3538
www.cedlevator.com

Elevator Hoistway Cable 600V

Stranded Hoistway—600V

Part Number	Size and Number of Components				Outside Diameter		Weight	
	14 AWG (2.08mm ²)	18 AWG (.82mm ²)	20 AWG Shld Pair 2x(.51mm ²)	COAX	inches	mm	lbs./Mft	kg/km
HC0314	3				0.29	4.6	59	88
HC0814SPL	8				0.42	11.4	158	228
HC1414	14				0.60	15.2	222	330
HC0418		4			0.25	6.4	39	58
HC0718		7			0.35	8.1	68	101
HC1018		10			0.42	10.7	97	144
HC1418		14			0.46	11.7	135	201
HC1918		19			0.53	13.5	184	274
HC2418		24			0.63	16.0	232	345
HC3018		30			0.67	17.1	291	433
HC3718		37			0.74	18.7	358	533
HC3718SPL		37			0.74	18.7	358	553
HC4218		42			0.84	21.3	407	606
HC6118		61			0.95	24.0	591	879
HCC39	4	35			0.82	20.7	418	622
HCC42	14	24	2		0.96	24.4	599	891
HCC49	4	45			0.92	23.4	515	766
HCC57	4	40	6	1	1.05	26.7	606	902
HCC62	4	58			1.02	25.9	641	954
HCC71	6	61	2		1.14	28.9	786	1170

The data herein is approximate and subject to normal manufacturing tolerances. These specifications are subject to change without notice.

*Cables with SPL designation have a special numbering sequence and/or conductor color arrangement:

HC0814SPL: non-standard conductor colors: #1/green; #2-#4/white; #5-#8/black

HC2118SPL: conductors are numbered 32 to 52

HC3718SPL: conductors are numbered 38 to 74

Stationary Wiring Shielded Pairs

Audio and Communication

300V Audio systems requiring circuit isolation, data control, and process control computer systems.

Construction

Single and Multi-paired, individually shielded per UL 2464, AWM, CL2 and CSA 300V 80C

Insulated Conductors:

Composed of 20 AWG stranded tinned copper, insulated with 80°C semi-rigid polyvinyl chloride, shielded with polyester/aluminum tape for 100% coverage over each pair, 22awg stranded tinned copper drain wire under the shield

Jacket:

Outer sheath is a chrome polyvinyl chloride (PVC) that provides a smooth, wear-resistant surface.

Stationary Wiring Shielded Pairs

300 Volt/Jacketed/for Audio and Data Communications

Part Number	Number of Components		Outside Diameter		Weight	
	20 AWG PR 2x(.51mm ²)		inches	mm	lbs./Mft	kg/km
M13141	1		0.191	4.9	22	33
M13142	2		0.223	5.7	34	51
M13143	3		0.297	7.5	50	74
M13144	4		0.330	8.4	66	98
M13146	6		0.394	10	91	135
M13149	9		0.459	11.4	130	193
M13152	12		0.517	13.1	165	246

Color Codes

- 1 Pair = Red/White
- 2 Pair = Black/White
- 3 Pair = Black/Green
- 4 Pair = Black/Blue
- 5 Pair = Black/Yellow
- 6 Pair = Black/Brown
- 7 Pair = Black/Orange
- 8 Pair = Red/White
- 9 Pair = Red/Green
- 10 Pair = Red/Blue
- 11 Pair = Red/Yellow
- 12 Pair = Red/Brown
- 13 Pair = Red/Orange
- 14 Pair = Green/White
- 15 Pair = Green/Blue

Compensating Cable

Compensating Cable is designed to reduce sway and provide a dampening effect to provide for smooth operation at temperatures between -15°C to +60°C. For use in the US, in elevators with rated speeds of 700 ft/min (3.56 m/sec) or less.

Construction

1. Chain

Low-carbon, electrically-welded proof coil chain. Each link is proof tested at two times the working load limit.

2. Inner Insulation (not shown)

Polyvinyl chloride insulation (PVC) extruded to form a round cross-section.

3. Jacket

A 60°C flame-retardant polyvinyl chloride (PVC) jacket designed to reduce oxidation, weathering, chemical and flame resistant.

Pre-stripped Compensating Cable is available.
Call CED for details.

Compensating Cable

Part Number	Cable Weight lb./ft. • kg/m	Cable Nom. O.D. inches • mm	Max. Hang Length feet • meters	Rec. Nom. Loop Width inches • mm
CC10	1.0 • 1.5	1.250 • 31.8	600 • 183	24 • 610
CC15	1.5 • 2.2	1.415 • 35.9	600 • 183	24 • 610
CC20	2.0 • 3.0	1.650 • 41.9	600 • 183	26 • 660

* Other sizes available upon request

CED can help you determine which size of Compensating Cable to use. Call us and have the following information ready:

- 1) Number of hoist ropes per car
- 2) Outer diameter of the hoist ropes
- 3) Stranding of the hoist ropes
(i.e. 8 x 19, 8 x 25...)
- 4) Car roping (i.e. 1:1, 2:1, other...)
- 5) Number of cables per car
- 6) Length of cable needed



Coaxial

Inner Conductor: No. 20 AWG
(6 strands of .010" tinned copper around
1 strand of .010" tinned copper-covered steel)

Nominal D.C. Resistance: 16.2 ohms/1000 ft.
(53 ohms/Km)

Dielectric: Cellular polypropylene

Nominal Impedance: 75 ohms

Nominal Capacitance: 18 pF/ft. (59 pF/m)

Nominal Velocity of Propagation: 78%

Shield: 85% coverage copper over a laminated
polyester and aluminum foil for 100% coverage

Nominal D.C. Resistance:
8.3 ohms/1000 ft. (27 ohms/Km)

Nominal Attenuation:

MHz	dB/100 ft.	dB/100 m
1	0.4	1.3
5	0.8	2.6
10	1.0	3.3
50	2.1	6.9
100	3.0	9.8

Steel Core for Elevator Traveling Cable

The steel support cables utilized in elevator traveling cables are flexible or extra flexible constructions specifically designed and selected for their high strength, resistance to fatigue and minimum stretch characteristics.

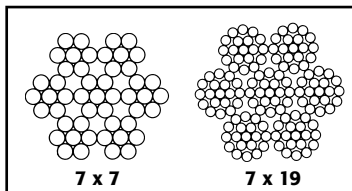

Manufactured to U.S. military specification MIL-W-83420, the individual wires are fully preformed and galvanized to provide maximum service life.

Inches	Diameter		Construction	Breaking Strength		Weight	
	Dec. In.	mm		lbs.	kg	lbs/Mft	kg/km
3/32	.0938	2.381	7x7	920	417	16	24
1/8	.1250	3.175	7x19	2000	907	29	43
5/32	.1563	3.969	7x19	2800	1270	45	67
3/16	.1875	4.763	7x19	4200	1905	65	97
1/4	.2500	6.350	7x19	7000	3175	110	164
3/8	.3750	9.525	7x19	14400	6532	243	362

Elevator Cable Technical Information

Color Code Chart

Gauge	Cond. Number	Color	Pr. Color
14 AWG	1	Black	N/A
	2	White	N/A
	3	Green	N/A
	4-10	Lavender	N/A
	11-20	Orange	N/A
16 AWG	1-10	Yellow	N/A
	or 11-20	Orange	N/A
18 AWG	21-30	Tan	N/A
	or 31-40	Blue	N/A
20 AWG	41-50	Red	N/A
	51-60	Gray	N/A
	61-70	Black	N/A
	71-80	Pink	N/A
	81-90	Brown	N/A
	91-100	Purple	N/A
Shielded Pairs	1	Blue	Red-White
	2	Purple	Red-White
	3	Black	Red-White
	4	Orange	Red-White
	5	Yellow	Red-White
	6	White	Red-White
	7	Brown	Red-White
	8	Green	Red-White
	9	Blue	Black-White
	10	Purple	Black-White
	11	Black	Black-White
	12	Orange	Black-White
	13	Yellow	Black-White
	14	White	Black-White
	15	Brown	Black-White
	16	Green	Black-White

Coaxial			
1	Black	N/A	
2	Black/White	N/A	

Metric Cross-Reference

AWG	Wire Size		Stranding	
	mm2	#/Diam. in.	#/Diam. mm	
14	2.080	41/.010"	41/.254	
16	1.310	26/.010"	26/.254	
18	0.823	16/.010"	16/.254	
20	0.519	10/.010"	10/.254	
22	0.348	7/.010"	7/.254	

Questions? Answers at...
(866) CED-ELEV • (866) 233-3538
www.cedlevator.com

Cable Installation Kits, Damping Devices

Compensating Cable Installation Kits

Each installation hardware kit includes:

2 Support Brackets (includes grade 8 nut, bolts, heavy duty cable TIE, lockwashers and hardened washers), 1 U-bolt (includes nuts and washers), 1 S-hook, 1 heavy duty grip and electrical tape

For safe and economical installation, when used as recommended, this system will provide you with safe operation of your compensating cable. An installation guide is provided with each kit.

Part Number	For Use on Cable	S-hook Part Number	Grip Part Number	3/4" Electrical Tape Part Number
CC10KIT	CC10	SH1	024-20-1504	MMM 33+
CC15KIT	CC15	SH3	024-20-1470	MMM 33+
CC20KIT	CC20	SH3	024-20-1510	MMM 33+
CC25KIT	CC25	SH6	024-20-1510	MMM 33+
CC30KIT	CC30	SH6	024-20-1499	MMM 33+
CC35KIT	CC35	SH6	024-20-1499	MMM 33+
CC40KIT	CC40	SH6	024-20-1542	MMM 33+

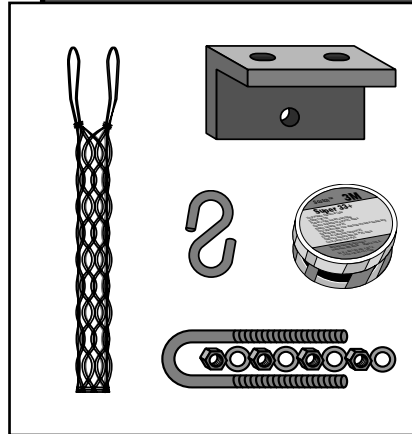

SteadyRoller™ Damping Device Kit

Compact, maintenance-free damping device with self-lubricating, free-spinning rollers for elevator compensating cable. The device has four sturdy, vibration-resistant corner posts and a support bracket that keeps the cable tracking smoothly without pinching, and provides the most protection against wear.

Part Number **APK0008** SteadyRoller



PhlexGrip™ Cable Hanging Support Bracket

Compact, maintenance-free damping device with self-lubricating, free-spinning rollers for elevator compensating cable. The device has four sturdy, vibration-resistant corner posts and a support bracket that keeps the cable tracking smoothly without pinching, and provides the most protection against wear.

Part Number **1SBKT 5/32**

Traveling Cable Support Bracket for 5/32 Steel Cable



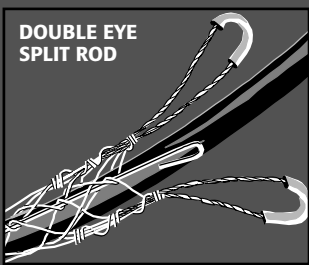
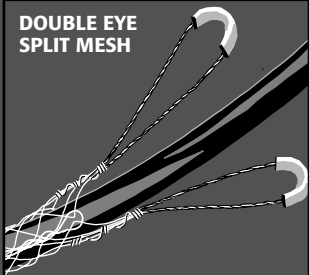
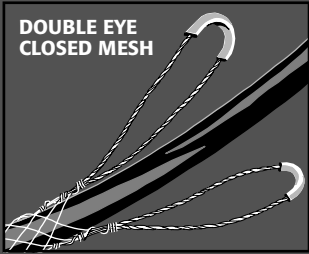
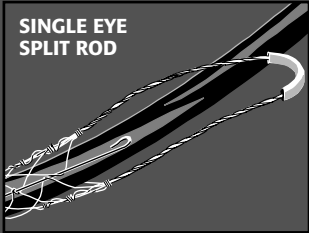
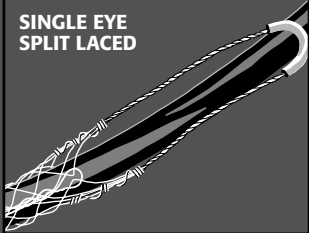
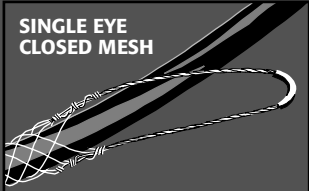

Kellems® Grips—Tinned Bronze

Single Eye Design/Single Weave—Closed Mesh & Split Rod

Part Number Closed Mesh	Part Number Split Laced	Cable Dia. Range inches • cm	Approx. Breaking Wt. lbs • kg	Eye Length inches • cm	Nom. Mesh Length inches • cm
022-01-013	022-02-013	.50 to .62 • 1.27 to 1.57	530 • 240	7 • 17.8	10 • 25.4
022-01-014	022-02-014	.63 to .74 • 1.60 to 1.88	790 • 358	8 • 20.3	10 • 25.4
022-01-015	022-02-015	.75 to .99 • 1.91 to 2.51	1020 • 463	8 • 20.3	13 • 33.0
022-01-017	022-02-017	1.00 to 1.24 • 2.54 to 3.15	1610 • 730	9 • 22.9	14 • 35.6
022-01-018	022-02-018	1.25 to 1.49 • 3.18 to 3.78	1610 • 730	10 • 25.4	15 • 38.1
022-01-019	022-02-019	1.50 to 1.74 • 3.81 to 4.42	1610 • 730	12 • 30.5	17 • 43.2
022-01-020	022-02-020	1.75 to 1.99 • 4.45 to 5.05	2150 • 975	14 • 35.6	19 • 48.3

Single Eye Design/Single Weave—Split Rod

Part Number	Cable Dia. Range inches • cm	Approx. Breaking Wt. lbs • kg	Eye Length inches • cm	Nom. Mesh Length inches • cm
022-03-013	.50 to .62 • 1.27 to 1.57	530 • 240	7 • 17.8	8.5 • 21.6
022-03-014	.63 to .74 • 1.60 to 1.88	790 • 358	8 • 20.3	8.5 • 21.6
022-03-015	.75 to .99 • 1.91 to 2.51	1020 • 463	8 • 20.3	10.5 • 26.7
022-03-017	1.00 to 1.24 • 2.54 to 3.15	1610 • 730	9 • 22.9	12.5 • 31.7
022-03-018	1.25 to 1.49 • 3.18 to 3.78	1610 • 730	10 • 25.4	14.5 • 36.8
022-03-019	1.50 to 1.74 • 3.81 to 4.42	1610 • 730	12 • 30.5	15.5 • 39.4
022-03-020	1.75 to 1.99 • 4.45 to 5.05	2150 • 975	14 • 35.6	16.5 • 41.9

Double Eye Design/Single Weave—Closed Mesh & Split Laced

Part Number Closed Mesh	Part Number Split Laced	Cable Dia. Range inches • cm	Approx. Breaking Wt. lbs • kg	Eye Length inches • cm	Nom. Mesh Length inches • cm
022-01-001	022-02-001	.50 to .62 • 1.27 to 1.57	530 • 240	4 • 10.2	10 • 25.4
022-01-002	022-02-002	.63 to .74 • 1.60 to 1.88	530 • 240	4 • 10.2	10 • 25.4
022-01-003	022-02-003	.75 to .99 • 1.91 to 2.51	1020 • 463	4 • 10.2	13 • 33.0
022-01-005	022-02-005	1.00 to 1.24 • 2.54 to 3.15	1610 • 730	5 • 12.7	14 • 35.6
022-01-006	022-02-006	1.25 to 1.49 • 3.18 to 3.78	1610 • 730	5 • 12.7	15 • 38.1
022-01-007	022-02-007	1.50 to 1.74 • 3.81 to 4.42	1610 • 730	5 • 12.7	17 • 43.2
022-01-008	022-02-008	1.75 to 1.99 • 4.45 to 5.05	2150 • 975	6 • 15.2	19 • 48.3

Double Eye Design/Single Weave—Split Rod

Part Number	Cable Dia. Range inches • cm	Approx. Breaking Wt. lbs • kg	Eye Length inches • cm	Nom. Mesh Length inches • cm
022-03-001	.50 to .62 • 1.27 to 1.57	790 • 358	4 • 10.2	8.5 • 21.6
022-03-002	.63 to .74 • 1.60 to 1.88	790 • 358	4 • 10.2	8.5 • 21.6
022-03-003	.75 to .99 • 1.91 to 2.51	1020 • 463	4 • 10.2	10.5 • 26.7
022-03-005	1.00 to 1.24 • 2.54 to 3.15	1610 • 730	5 • 12.7	12.5 • 31.7
022-03-006	1.25 to 1.49 • 3.18 to 3.78	1610 • 730	5 • 12.7	14.5 • 36.8
022-03-007	1.50 to 1.74 • 3.81 to 4.42	1610 • 730	5 • 12.7	15.5 • 39.4
022-03-008	1.75 to 1.99 • 4.45 to 5.05	2150 • 975	6 • 15.2	16.5 • 41.9

Component Specifications

These grips are intended for low rise installations only! Listed breaking strengths should not be loaded more than 25% to ensure a four-to-one safety factor. To maintain original grip set, the base of all grips should be secured with vinyl tape.

Questions? Answers at...
(866) CED-ELEV • (866) 233-3538
www.cedlevator.com

Kellems® Grips—Stainless Steel



Single Eye Design/Single Weave/Split Rod

Part Number	Cable Dia. Range inches • cm	Approx. Breaking Wt. lbs • kg	Eye Length inches • cm	Nom. Mesh Length inches • cm
024-03-014	.63 to .74 • 1.60 to 1.88	2000 • 908	8 • 20.3	8.5 • 21.6
024-03-015	.75 to .99 • 1.91 to 2.51	2050 • 930	8 • 20.3	10.5 • 26.7
024-03-017	1.00 to 1.24 • 2.54 to 3.15	2650 • 1202	9 • 22.9	12.5 • 31.7
024-03-018	1.25 to 1.49 • 3.18 to 3.78	4500 • 2041	10 • 25.4	14.5 • 36.8
024-03-019	1.50 to 1.74 • 3.81 to 4.42	4500 • 2041	12 • 30.5	15.5 • 39.4

Double Eye Design/Double Weave/Closed Mesh

Part Number	Cable Dia. Range inches • cm	Approx. Breaking Wt. lbs • kg	Eye Length inches • cm	Nom. Mesh Length inches • cm
024-20-1504	1.00 to 1.24 • 2.54 to 3.15	6000 • 2722	12 • 30.5	14 • 35.6
024-20-1470	1.25 to 1.49 • 3.18 to 3.78	8200 • 3720	12 • 30.5	15 • 38.1
024-20-1510	1.50 to 1.74 • 3.81 to 4.42	8300 • 3765	12 • 30.5	17 • 43.2
024-20-1499	1.75 to 1.99 • 4.45 to 5.05	15000 • 6804	12 • 30.5	19 • 48.3
024-20-1542	2.00 to 2.50 • 5.08 to 6.35	15000 • 6804	12 • 30.5	22 • 55.9

Double Eye Design/Double Weave/Split Laced

Part Number	Cable Dia. Range inches • cm	Approx. Breaking Wt. lbs • kg	Eye Length inches • cm	Nom. Mesh Length inches • cm
024-20-1284	.75 to .99 • 1.91 to 2.51	3100 • 1406	4 • 10.2	13 • 33.0
024-20-1285	1.00 to 1.24 • 2.54 to 3.15	4000 • 1814	4 • 10.2	14 • 35.6
024-20-1286	1.25 to 1.49 • 3.18 to 3.78	4000 • 1814	4 • 10.2	15 • 38.1
024-20-1287	1.50 to 1.74 • 3.81 to 4.42	4000 • 1814	4 • 10.2	17 • 43.2
024-20-1500	1.75 to 2.00 • 4.45 to 5.08	11000 • 4990	12 • 30.5	19 • 48.3

Double Eye Design/Single Weave/Split Rod

Part Number	Cable Dia. Range inches • cm	Approx. Breaking Wt. lbs • kg	Eye Length inches • cm	Nom. Mesh Length inches • cm
024-03-005	1.00 to 1.24 • 2.54 to 3.15	2650 • 1202	5 • 12.7	12.5 • 31.7
024-03-006	1.25 to 1.49 • 3.18 to 3.78	4500 • 2041	5 • 12.7	14.5 • 36.8
024-03-007	1.50 to 1.74 • 3.81 to 4.42	4500 • 2041	5 • 12.7	15.5 • 39.4

Component Specifications

These grips are intended for mid- and high-rise installations, and could be used as the primary hanging method for cables up to 200' (61 meters) in travel. Installations of over 40 stories should utilize the heavy duty double-weave grips for back-up purposes ONLY and not as the primary hanger. To maintain original grip set, the base of all grips should be secured with vinyl tape.

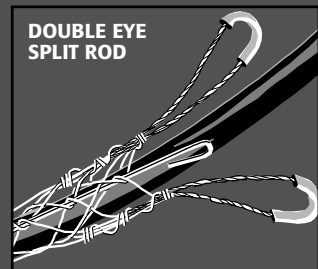
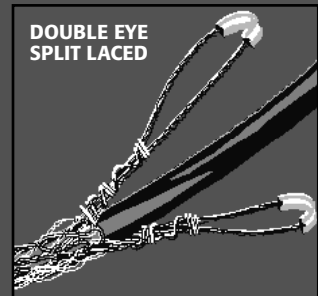
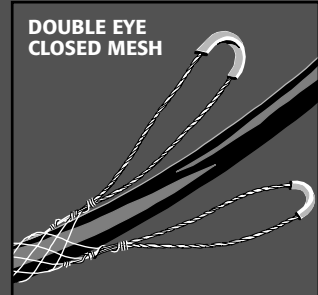
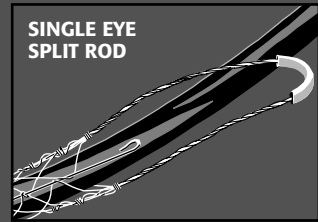

Questions? Answers at...
 (866) CED-ELEV • (866) 233-3538
www.cedlevator.com

Barclays California Code of Regulations

(applies to 1970–August 8, 1997)

2.(c) Guarding of Counterweights in a Multiple-Elevator Hoistway

(1) Where counterweights are located between elevators in a hoistway having more than one elevator, the counterweight shall be guarded for the entire height of the hoistway. The guard shall extend at least 6 inches horizontally beyond each counterweight rail. The guard shall be made from wire-mesh material equal to or stronger than .048-inch diameter wire with openings not exceeding 1/2-inch, securely fastened to keep the guard taut and plumb.

(2) The guarding of counterweights required in Section 3013(c)(1) shall be accomplished within three years of the effective date of this regulation. (Title 24, Part 7, Section 7–3013.)

OSHA Regulations require the installation of screening between adjacent elevator hoistways to protect workers from injury.

The National Elevator Industry's Field Employee Safety Handbook, Section 8.3, "Hoistway Screening," requires that, "When an elevator is operating in a multiple hoistway, and construction or modernization work is to be performed, in an adjacent position of that multiple hoistway, that portion of the elevator hoistway where the work is to be performed, shall be fully separated."

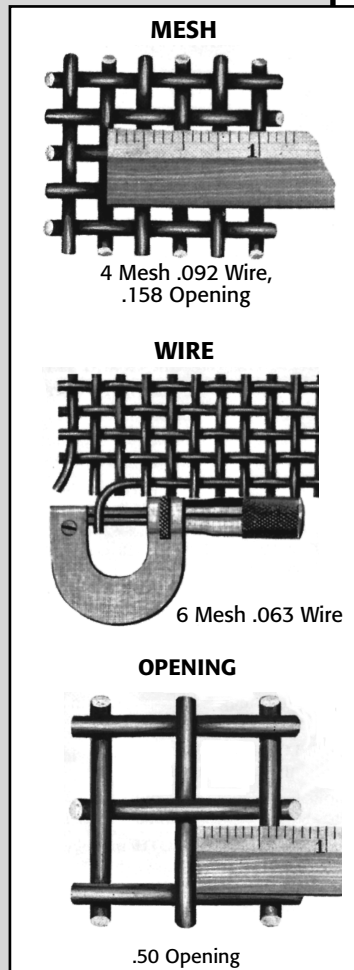

Hoistway Safety Netting & Guard System

Square Mesh Wire Cloth

- Galvanized, Hot-Dipped after Welded
- Mesh: 1/2" x 1/2" (center to center)
- .063" diameter wire
- Rolls are 100 feet long and are available in widths of 18, 24, 30, 36, 48, 60 and 72 inches.

Specifications

Mesh

Number of openings per lineal inch. Measured from the center of wires. The number of openings precedes the word "Mesh."

Wire

The diameter of wire (in decimals) used in weaving cloth.

Opening

The size of clear opening between parallel wires. For a given mesh, the space is determined by the diameter of wire used.

PearlWeave Hoistway Safety Netting

PearlWeave netting, when installed vertically inside elevator hoistways, provides protection equivalent to that of wire mesh. It replaces screening behind traveling cables, protects counterweight frames, and most important, protects workers working inside of one hoistway from straying into the adjacent hoistway or the area between counterweight rails, thereby preventing serious injury, and even loss of life.

PearlWeave safety netting products are lightweight, durable and easier to use than traditional wire meshes, while exceeding their strength characteristics. Our chemical- and mildew-resistant products, are also flame retardant, and if burned, will not emit toxins into the hoistway.

Available in 48in. x 150ft. rolls

Hoistway Guard Systems

Hoistway guard systems are used to prevent round and flat traveling cable from striking obstructions in the hoistway and from crossing over into adjoining hoistways. Their use may extend the life span and prevent possible interference of your installed elevator cables.

Our guarding systems are available in two sizes, each containing 100ft x 1.5ft of 1/2"x 1/2" wire mesh, installation hardware, and detailed installation instructions.

Part Number	Description
HGS	Hardware, mesh and base mounting kit
HGS-EXT	Hardware, mesh and extension mounting kit (used to extend HGS an additional 100ft)

Questions? Answers at...
 (866) CED-ELEV • (866) 233-3538
 www.cedlevator.com

Cable & Wire Cutting Tools

Super Peeler

The Cadillac of cable stripping tools! Easy to calibrate and use, this unique cable "peeler" allows you to precisely score round traveling cable jackets for fast removal without nicking the conductors underneath. Just a turn of the dial adjusts the spring-loaded blade from 20 to 70 mils (0.5 to 1.8 mm).

Part Number	Description	Standard Packaging
BP1A	For cable dia. 0.75 to 1.25 in (19 to 32 mm)	1
BP2A	For cable dia. 1.25 to 2.00 in (32 to 51 mm)	1
34230	Replacement blade for either Super Peeler	1

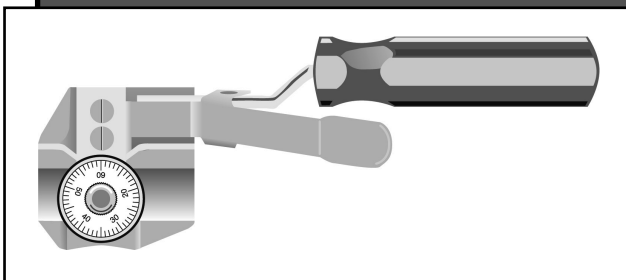

Roto-Peeler

An easy-to-use blade that allows you to lock in the required cutting depth as to cleanly strip away the jacket, yet leave the individual conductor insulation undisturbed. The blade also can be positioned to allow circular, spiral and longitudinal cutting of the jacket. Designed for cable from 0.75 to 1.58 in (19 to 40 mm) in diameter.

Part Number	Description	Standard Packaging
1903	Roto-Peeler	1

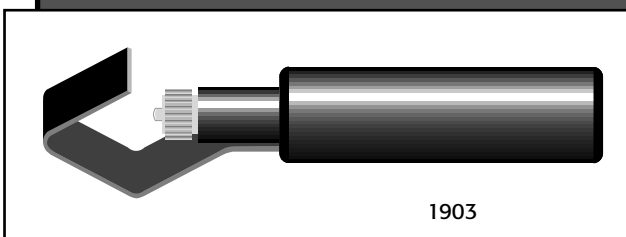

Sock Slicer

Part Number	Description	Standard Packaging
Sock Slicer	Rotary Cutter for Traveler Sock	1



Steel Core Cutters

High-leverage cutters with Swiss-made carbide steel blades that make quick work of the steel reinforcement cable in traveling cables. Plastic-coated handles for comfort and grip. Blades lock in a closed position for better fit in a toolbelt.

Part Number	Description	Standard Packaging
63016	Steel Core Cutters	1
63050	9-1/2" Aircord & Cable Cutter (AKA Cadillacs)	

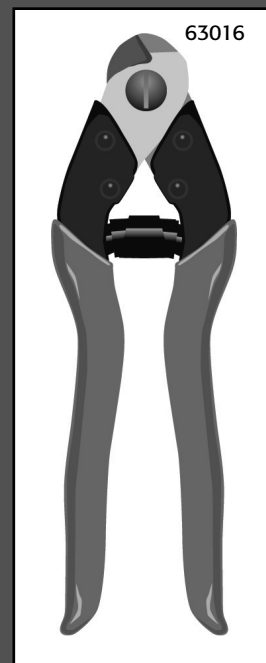

Questions? Answers at...
 (866) CED-ELEV • (866) 233-3538
www.cedelevator.com

CONTACTORS, STARTERS, RELAYS & TIMERS

3

In this Section

Sprecher + Schuh Control	
AC Contactors	3.2-4
Overload Relays	3.5
PCEC Soft Starters	3.6
CS7 Control Relays	3.7
CA8 Contactors and CS8 Control Relays	3.8
Schneider/Telemecanique Control	
AC Contactors	3.9-3.10
Overload Relays	3.11
Control Relays	3.12
General Electric Control	
3-Pole Reversing Contactors	3.14
Control Relays	3.15
Siemens Control	
AC Contactors	3.16-17
Control Relays	3.18
Class 40 Contactors	3.19
Elevator Soft Starter	3.20
ABB Control	
AC Contactors & Overload Relays	3.23-25
DC Contactors	3.26
Definite Purpose Contactors	
Schneider Electric	3.27
General Purpose Relays	
Open Power Relays	3.28-29
Ice Cube Relays	3.30
Minature Relays	3.31
Blade Base Relays	3.33
Relay Bases	3.34
Misc & Special Purpose Relays	3.35
Phase Monitoring Relays	3.36
Timing Relays	3.37

Sprecher & Schuh 3-Pole Contactors

CONTACTORS, STARTERS, RELAYS & TIMERS

Part Number* AC Operated	DC Operated	Nema Equivalents	Maximum Horsepower Ratings				Maximum Inductive			
			1-phase 50/60 Hz		3-PHASE 50/60 Hz		Current (Amps)	Aux		
			115/120V	230/240V	200/208V	220/240V	460/480V	575/600V	N/O	N/C
CA7-9-10-*	CA7-9E-10-*	Size 00	0.5	1.5	2	2	5	7.5	9	1 0
CA7-9-01-*	CA7-9E-01-*	"	0.5	1.5	2	2	5	7.5	9	0 1
CA7-12-10-*	CA7-12E-10-*	"	0.5	2	3	3	7.5	10	12	1 0
CA7-12-01-*	CA7-12E-01-*	"	0.5	2	3	3	7.5	10	12	0 1
CA7-16-10-*	CA7-16E-10-*	SIZE 0	1	3	5	5	10	15	16	1 0
CA7-16-01-*	CA7-16E-01-*	"	1	3	5	5	10	15	16	0 1
CA7-23-10*	CA7-23E-10*	SIZE 1	2	3	5	7.5	15	15	23	1 0
CA7-23-10*	CA7-23E-10*	"	2	3	5	7.5	15	15	23	1 0
CA7-30-00-*	CA7-30E-00-*	"	2	5	7.5	10	20	25	30	0 0
CA7-37-00-*	CA7-37E-00-*	"	3	5	10	10	25	30	37	0 0
CA7-43-00-*	CA7-43E-00-*	SIZE 2	3	7.5	10	15	30	30	43	0 0
CA7-60-00-*	CA7-60D-00-*	"	5	10	15	20	40	50	60	0 0
CA7-72-00-*	CA7-72D-00-*	"	5	15	20	25	50	60	72	0 0
CA7-85-00-*	CA7-85D-00-*	SIZE 3	7.5	15	25	30	60	60	85	0 0
CA7-97-00-*	CA7-97-00-*	"	7.5	15	30	30	75	75	95	1 1
CA6-115-EI-11-*	CA6-115-EI-11-*	"	10	25	40	40	75	100	110	1 1
CA6-140-EI-11-*	CA6-140-EI-11-*	SIZE 4	15	30	40	50	100	125	140	1 1
CA6-180-EI-11-*	CA6-180-EI-11-*	"		40	50	60	150	150	180	1 1
CA6-210-EI-11-*	CA6-210-EI-11-*	"		50	60	75	150	200	210	1 1
CA6-250-EI-11-*	CA6-250-EI-11-*	SIZE 5			75	100	200	250	250	1 1
CA6-300-EI-11-*	CA6-300-EI-11-*	"			100	125	250	300	300	1 1
CA6-420-EI-11-*	CA6-420-EI-11-*	"			150	175	350	400	420	1 1
CA6-630-EI-11-*	CA6-630-EI-11-*	SIZE 6			200	250	500	600	630	1 1
CA6-860-EI-11-*	CA6-860-EI-11-*	SIZE 7			250	300	600	700	860	1 1

*Please add coil voltage when ordering.

** For additional accessory info call and speak with a salesperson.

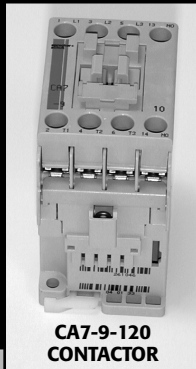

CA7-9-120 CONTACTOR

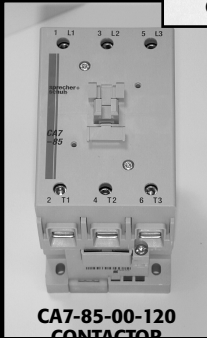

CA7-85-00-120 CONTACTOR

Part Number	N.O.	N.C.	Mount
CS7-PV-10	1	0	Front
CS7-PV-01	0	1	Front
CS7-PV-11	1	1	Front
CS7-PV-20	2	0	Front
CS7-PV-02	0	2	Front
CS7-PV-22	2	2	Front
CS7-PV-13	1	3	Front
CS7-PV-31	3	1	Front
CS7-PV-40	4	0	Front
CS7-PV-04	0	4	Front
CA7-PA-10	1	0	Side
CA7-PA-01	0	1	Side
CA7-PA-20	2	0	Side
CA7-PA-02	0	2	Side
CA7-PA-11	1	1	Side
CA7-PA-L11	1EM	1LB	Side

CA6 Aux Blocks

Part Number	N.O.	N.C.	Mount
CA6-S1-11	1	1	Inside left or right
CA6-S2-11	1	1	Outside left or right
CA6-S1-L11	1	1LB	Inside left or right
CA6-S1-20	2	0	Inside left or right
CA6-S2-20	2	0	Outside left or right

CS7 CONTACTORS

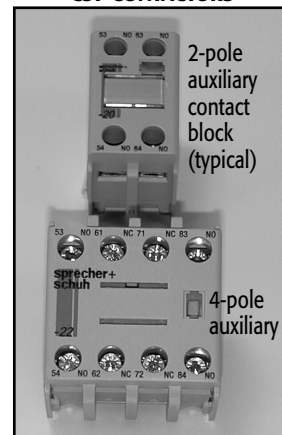

2-pole auxiliary contact block (typical)

4-pole auxiliary

CA7 CONTACTORS

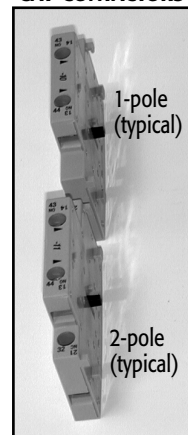

1-pole (typical)

2-pole (typical)

Questions? Answers at...
(866) CED-ELEV • (866) 233-3538
www.cedlevator.com

Sprecher & Schuh Mechanically Interlocked Contactors

CA7 Mechanically & Electrically Interlocked Contactors

Part Number* AC Operated	DC Operated	Maximum Inductive Current Nema Equivalents (3 Wire)	Amps	3-Phase 50/60 Hz										Aux	
				Line Connected - 3 Wire				Delta Connected - 6 Wire							
				1-phase 50/60 Hz	Reversing Contactor	Remove the load side poer buss for wye-delta use		Supplied as a 3 wire reversing contactor							
CAU7-9-22-*	CAU7-9E-22-*	Size 00	9	0.5	1.5	2	2	5	7.5	5	5	10	10	2	2
CAU7-12-22-*	CAU7-12E-22-*	"	12	0.5	2	3	3	7.5	10	5	7.5	15	15	2	2
CAU7-16-22-*	CAU7-16E-22-*	SIZE 0	16	1	3	5	5	10	15	7.5	10	20	20	2	2
CAU7-23-22*	CAU7-23E-22*	SIZE 1	23	2	3	5	7.5	15	15	7.5	10	25	25	2	2
CAU7-30-22-*	CAU7-30E-22-*	"	30	2	5	7.5	10	20	25	10	15	30	30	2	2
CAU7-37-22-*	CAU7-37E-22-*	"	37	3	5	10	10	25	30	15	20	40	40	2	2
CAU7-43-22-*	CAU7-43E-22-*	SIZE 2	43	3	7.5	10	15	30	30	20	25	50	50	2	2
CAU7-60-22-*	CAU7-60D-22-*	"	60	5	10	15	20	40	50	30	40	75	75	2	2
CAU7-72-22-*	CAU7-72D-22-*	"	72	5	15	20	25	50	60	40	50	100	100	2	2
CAU7-85-22-*	CAU7-85D-22-*	SIZE 3	85	7.5	15	25	30	60	60	50	60	125	125	2	2
CAU7-97-22-*	CAU7-97-22-*	"	97	7.5	15	30	30	75	75	50	60	125	125	2	2
CAU6-115-EI-22-*	CAU6-115-EI-22-*	"	110	10	25	40	40	75	100	SEE PCEC SOFT STARTER SECTION				2	2
CAU6-140-EI-22-*	CAU6-140-EI-22-*	SIZE 4	140	15	30	40	50	100	125					2	2
CAU6-180-EI-22-*	CAU6-180-EI-22-*	"	180	40	50	60	150	150	2					2	
CAU6-210-EI-22-*	CAU6-210-EI-22-*	"	210	50	60	75	150	200	2					2	
CAU6-250-EI-22-*	CAU6-250-EI-22-*	SIZE 5	250	75	100	200	250	2	2						
CAU6-300-EI-22-*	CAU6-300-EI-22-*	"	300	100	125	250	300	2	2						
CAU6-420-EI-22-*	CAU6-420-EI-22-*	"	420	150	175	350	400	2	2						
CAU6-630-EI-22-*	CAU6-630-EI-22-*	SIZE 6	630	200	250	500	600	2	2						
CAU6-860-EI-22-*	CAU6-860-EI-22-*	SIZE 7	860	250	300	600	700	2	2						

REVERSING CONTACTORS

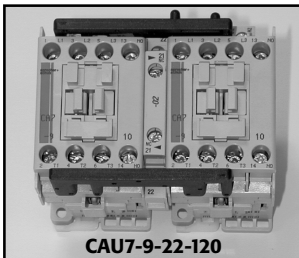

CAU7-9-22-120

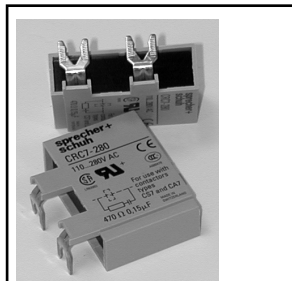

Surge Suppressors
Limits coil switching transients.
• Plug-in, coil mounted
• Suitable for all CS7 contactors

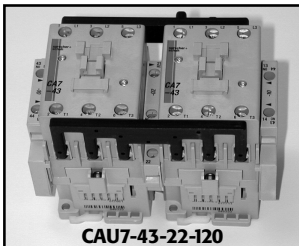

CAU7-43-22-120

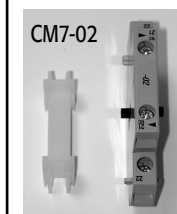

Mechanical/Electrical Interlocks
• Common to all CA7 contactors; interlocks different contactor sizes
• Mechanical and electrical interlocking possible in one module by means of integrated auxiliary contacts
• Dovetail (CA7-S9) connector included (9mm)

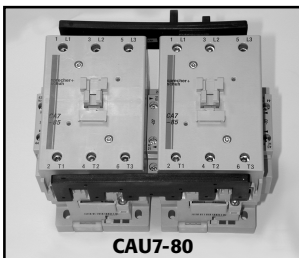

CAU7-80

Part Number	Type	Voltage Range
CRC7-48	RC Module	24-48vac
CRC7-280	RC Module	110-280vac
CRC7-480	RC Module	380-480vac
CRD7-250	Diode Module	12-240vdc
CRV7-55	Varistor Module	12-55vac 12-77vdc
CRV7-136	Varistor Module	56-136vac 78-180vdc
CRV7-277	Varistor Module	137-277vac 181-350vdc
CRV7-575	Varistor Module	278-575vac

Questions? Answers at...
(866) CED-ELEV • (866) 233-3538
www.cedlevator.com

**CA7-16-M40
CONTACTOR**

Sprecher & Schuh 4-Pole Contactors

Part Number*	Maximum Horsepower Ratings							Maximum Inductive Current (Amps)	Contact Configuration	
	AC Operated	DC Operated	1-phase 50/60 Hz		3-PHASE 50/60 Hz				Main Pole	
			115/120V	230/240V	200/208V	220/240V	460/480V		575/600V	N/O
CA7-9-M40*	CA7-9E-M40*	0.5	1.5	2	2	5	7.5	9	4	0
CA7-9-M31*	CA7-9E-M31*	0.5	1.5	2	2	5	7.5	9	3	1
CA7-9-M22*	CA7-9E-M22*	0.5	1.5	2	2	5	7.5	9	2	2
CA7-12-M40*	CA7-12E-M40*	0.5	2	3	3	7.5	10	12	4	0
CA7-12-M31*	CA7-12E-M31*	0.5	2	3	3	7.5	10	12	3	1
CA7-12-M22*	CA7-12E-M22*	0.5	2	3	3	7.5	10	12	2	2
CA7-16-M40*	CA7-16E-M40*	1	3	5	5	10	15	16	4	0
CA7-16-M31*	CA7-16E-M31*	1	3	5	5	10	15	16	3	1
CA7-16-M22*	CA7-16E-M22*	1	3	5	5	10	15	16	2	2
CA7-23-M40*	CA7-23E-M40*	2	3	5	7.5	15	15	23	4	0
CA7-23-M31*	CA7-23E-M31*	2	3	5	7.5	15	15	23	3	1
CA7-23-M22*	CA7-23E-M22*	2	3	5	7.5	15	15	23	2	2
CA7-40-M40*	CA7-40E-M40*	3	5	10	10	25	30	37	4	0
CA7-40-M22*	CA7-40E-M22*	3	5	10	10	25	15	37	2	2
CA7-90-M40*		7.5	15	25	30	60	50	85	4	0
CA7-90-M22*		7.5	15	25	30	50	20	95	2	2

Wye-Delta Contactors

Part Number*		Inductive Current Rating Amps	Maximum Horsepower Ratings				Electrical Interlock (Aux)	
100 ... 250VAC Operated	250 ... 500VDC Operated		3-PHASE 50/60 Hz				N/O	N/C
			220V	230V	460V	575V		
CA9Y2-116-22- EI-120W-LW	CA9Y2-116-22- EI-480W-LW	54	15	20	40	50	2	2
CA9Y2-146-22- EI-120W-LW	CA9Y2-146-22- EI-480W-LW	54	15	20	40	50	2	2
CA9Y2-190-22- EI-120W-LW	CA9Y2-190-22- EI-480W-LW	77	20	25	60	75	2	2
CA9Y2-205-22- EI-120W-LW	CA9Y2-205-22- EI-480W-LW	99	30	30	75	100	2	2
CA9Y2-265-22- EI-120W-LW	CA9Y2-265-22- EI-480W-LW	125	40	40	100	125	2	2
CA9Y2-305-22- EI-120W-LW	CA9Y2-305-22- EI-480W-LW	149	40	50	100	150	2	2
CA9Y2-370-22- EI-120W-LW	CA9Y2-370-22- EI-480W-LW	156	50	60	125	150	2	2

Questions? Answers at...
(866) CED-ELEV • (866) 233-3538
www.cedlevator.com

Sprecher & Schuh Overload Relays

Electronic Overload Relays

Adjustable trip class 10, 15, 20 & 30

Part Number	Adjustable Trip Range (Amps)	For Use with Contactors
CEP7-EECB	1 to 5	CA7-9 to CA7-23
CEP7-EEDB	3.2 to 16	CA7-9 to CA7-23
CEP7-EEEB	5.4 to 27	CA7-9 to CA7-23
CEP7-EEED	5.4 to 27	CA7-30 to CA7-43
CEP7-EEFD	9 to 45	CA7-30 to CA7-43
CEP7-EEFE	9 to 45	CA7-60 to CA7-85
CEP7-EEGE	18 to 90	CA7-60 to CA7-85
CEP7-EEJF	40 to 200	CA6-95 to CA6-180

*Additional sizes available

Panel Mount Adapters

Part Number	Fits Overload Type
CEP7-EPB	CEP7-EE...B
CEP7-EPD	CEP7-EE...D
CEP7-EPE	CEP7-EE...E
CT7N-37-P-A	CT7N-23...37

Thermal Overload Relays

Adjustable trip class 10

Part Number	Adjustable Trip Range (Amps)	For Use with Contactors
CT7N-23-B75	5.5 to 7.5	CA7-9 to CA7-23
CT7N-23-C10	7.2 to 10	CA7-9 to CA7-23
CT7N-23-C12	9 to 12.5	CA7-12 to CA7-23
CT7N-23-C16	11.3 to 16	CA7-16 to CA7-23
CT7N-23-C20	15 to 20	CA7-16 to CA7-23
CT7N-23-C25	21 to 25	CA7-16 to CA7-23
CT7N-37-C25	21 to 25	CA7-30 to CA7-37
CT7N-37-C30	24.5 to 30	CA7-30 to CA7-37
CT7N-37-C36	29 to 36	CA7-30 to CA7-37
CT7N-37-C38	33 to 38	CA7-37
CT7N-85-C47P	35 to 47	Separately mounted
CT7N-43-C25	17 to 25	CA7-43
CT7N-43-C36	24.5 to 36	CA7-43
CT7N-43-C47	35 to 47	CA7-43
CT7N-85-C47	35 to 47	CA7-60 to CA7-85
CT7N-85-C60	45 to 60	CA7-60 to CA7-85
CT7N-85-C60P	45 to 60	Separately mounted
CT7N-85-C75	58 to 75	CA7-85
CT7N-85-C75P	58 to 75	Separately mounted
CT7N-85-C90	72 to 90	CA7-85
CT7N-85-C90P	72 to 90	Separately mounted

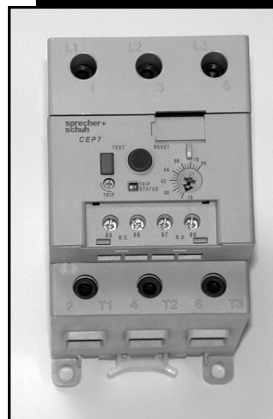
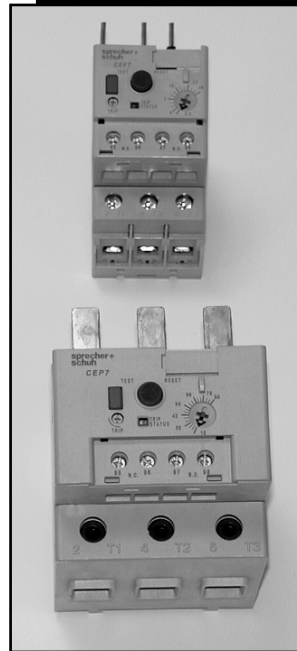

CONTACTORS, STARTERS, RELAYS & TIMERS

Questions? Answers at...
(866) CED-ELEV • (866) 233-3538
www.cedelevator.com

Sprecher & Schuh PCEC Hydraulic Elevator Softstarters



Thinking of replacing that old mechanical contactor with a softstarter but are concerned about it fitting... The PCEC is much smaller than other commonly used softstarters. It's the ideal wye-delta contactor replacement because it typically fits within the existing contactor footprint. The PCEC is supplied mounted to a back panel but the components will also snap on a DIN rail.

Diagnostics:

- Overload
- Over temp protection
- Phase reversal
- Phase loss/open Load
- Phase imbalance
- Shorted SCR
- Test overload

Features:

- Selectable overload class, 10, 15, 20, off
- Phase imbalance selectivity
- LED diagnostic & run display
- ½-sec "hold-in" display
- "Up-to-speed" contact

Part Number 120VAC Control Voltage	DELTA Connected (6 Wire) H.P. Ratings 3-PHASE 50/60 Hz				Overload Range (Amps)	LINE Connected (3 Wire) H.P. Ratings 3-PHASE 50/60 Hz				Overload Range (Amps)
	208V	240V	480V	575V		208V	240V	480V	575V	
PCEC-032-600V-120V	10	10	15	30	10.9...32.9	5	5	10	15	6.3...19
PCEC-051-600V-120V	15	15	30	40	17.3...51.9	7.5	10	20	25	10...30
PCEC-064-600V-120V	20	20	40	60	21...64	10	10	25	30	12.3...37
PCEC-074-600V-120V	20	25	50	60	25...74	10	15	30	40	14.3...43
PCEC-104-600V-120V	30	40	75	100	84.6...104	15	20	40	50	20...60
PCEC-147-600V-120V	40	50	100	150	50...147	25	30	60	75	28.3...85
PCEC-234-600V-120V	60	75	150	150	59...234	40	50	100	100	34...135

PCEC Assembly	PCE Controller Only	PCE Fans	Fault Contactor Coils*		
			Fault Contactor	120vac	208 - 240vac
PCEC-032-600V-120V	PCEC-032-600V		CA7-37-00-120		
PCEC-051-600V-120V	PCEC-051-600V	PCV-064	CA7-37-00-120	TC473	TC296
PCEC-064-600V-120V	PCEC-064-600V	(optional)	CA7-37-00-120		
PCEC-074-600V-120V	PCEC-074-600V		CA7-43-00-120	TD473	TD296
PCEC-104-600V-120V	PCEC-104-600V	PCV-147	CA7-60-00-120	TE473	TE296
PCEC-147-600V-120V	PCEC-147-600V		CA7-85-00-120	TE473	TE296
PCEC-234-600V-120V	PCEC-234-600V	PCV-234	CA6-180-EI-11-120	CA6-TGE865	CA6-TGE866

* The PCE controller's control voltage operating range is 100-240vac. The coil voltage of the fault contactor determines the control voltage of the PCEC assembly.

Dimensions

Controller Sizes	Units	Width	Height	Depth	Approx. Weight
32 / 51 / 64	mm inch	178 7.01	144 5.67	115.7 4.56	4 lbs
74 / 104 / 147	mm inch	240 9.45	225 8.86	147.9 5.82	14 lbs
234	mm inch	362 14.25	515 20.28	216.4 8.52	51 lbs

Part Number	N.O.	N.C.
PCS-PA-10	1	0
PCS-PA-01	0	1
PCS-PA-11	1	1

Questions? Answers at...
(866) CED-ELEV • (866) 233-3538
www.cedlevator.com

Sprecher & Schuh CS7 Control Relays

CS7 Control Relays

10 amp a/c, 5 amp d/c continuous

Part Number*		Contacts	
AC Operated	DC Operated	N/O	N/C
CS7-22E-*	CS7E-22E-*	2	2
CS7-31E-*	CS7E-31E-*	3	1
CS7-40E-*	CS7E-40E-*	4	0
CS7-04E-*	CS7E-04E-*	0	4*

Please add coil voltage when ordering.

CS7 Master Control Relays

20 amp a/c, 5 amp d/c continuous

Part Number*		Contacts	
AC Operated	DC Operated	N/O	N/C
CS7-M22E-*	CS7E-M22E-*	2	2
CS7-M31E-*	CS7E-M31E-*	3	1
CS7-M40E-*	CS7E-M40E-*	4	0
CS7-M04E-*	CS7E-M04E-*	0	4

*Please add coil voltage when ordering.

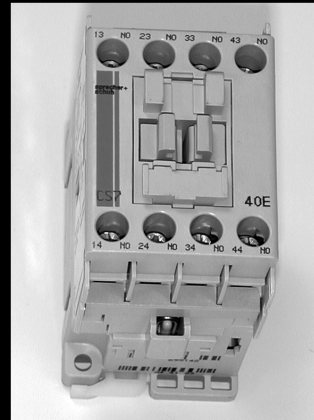

CS7 AUX B

Aux Blocks

Part Number	N.O.	N.C.	Mount
CS7-PV-10	1	0	Front
CS7-PV-01	0	1	Front
CS7-PV-11	1	1	Front
CS7-PV-20	2	0	Front
CS7-PV-02	0	2	Front
CS7-PV-22	2	2	Front
CS7-PV-13	1	3	Front
CS7-PV-31	3	1	Front
CS7-PV-40	4	0	Front
CS7-PV-04	0	4	Front
CA7-PA-10	1	0	Side
CA7-PA-01	0	1	Side
CA7-PA-20	2	0	Side
CA7-PA-02	0	2	Side
CA7-PA-11	1	1	Side
CA7-PA-L11	1EM	1LB	Side

*Additional types available.

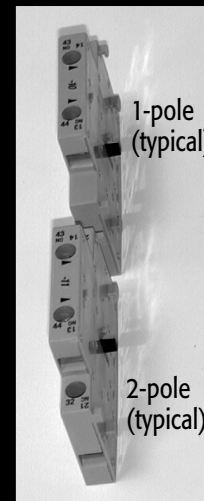
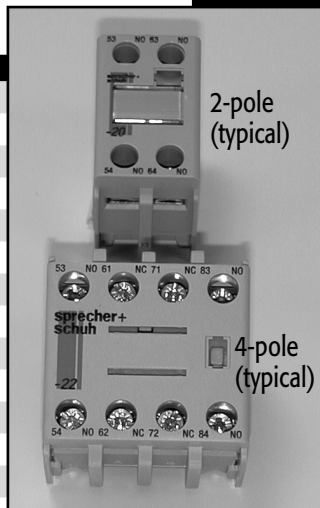

CA7 Surge Suppressors

Part Number	Type	Voltage Range
CRC7-48	RC Module	24-48vac
CRC7-280	RC Module	110-280vac
CRC7-480	RC Module	380-480vac
CRD7-250	Diode Module	12-240vdc
CRV7-55	Varistor Module	12-55vac 12-77vdc
CRV7-136	Varistor Module	56-136vac 78-180vdc
CRV7-277	Varistor Module	137-277vac 181-350vdc
CRV7-575	Varistor Module	278-575vac

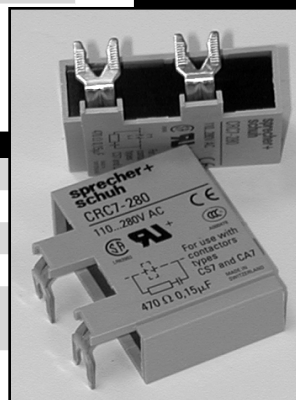

Pneumatic Timing Modules

Part Number	Type	Time Range
CZE7-30	On-Delay	0.1 to 3 s
CZE7-180	On-Delay	1.8 to 180 s
CZA7-30	Off-Delay	0.1 to 3 s
CZA7-180	Off-Delay	1.8 to 180

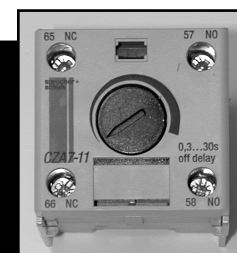

Questions? Answers at...
(866) CED-ELEV • (866) 233-3538
www.cedelevator.com

Sprecher & Schuh CA8 & CS8 Contactors & Relays

CA8 Contactors

Part Number*		Maximum Horsepower Ratings						Maximum Inductive		
AC Operated	DC Operated	1-phase 50/60 Hz		3-PHASE 50/60 Hz				Current (Amps)	Aux	
		115/120V	230/240V	200/208V	220/240V	460/480V	575/600V		N/O	N/C
CA8-9-10-*	CA8-9C-10-*	0.5	1.5	2	2	5	5	9	1	0
CA8-9-01-*	CA8-9C-01-*	0.5	1.5	2	2	5	5	9	0	1
CA8-12-10-*	CA8-12C-10-*	0.75	2	3	3	7.5	7.5	12	1	0
CA8-12-01-*	CA8-12C-01-*	0.75	2	3	3	7.5	7.5	12	0	1

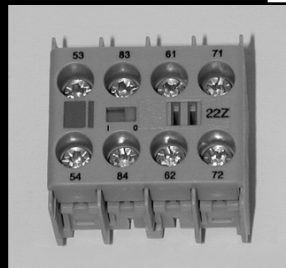
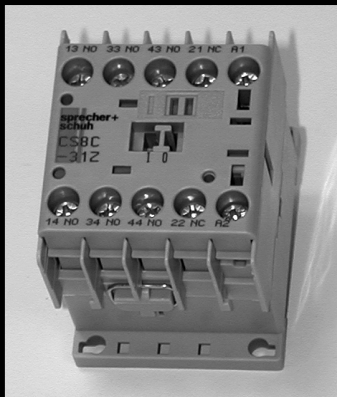

CS8 Control Relays

Part Number*		Contacts	
AC Operated	DC Operated	N/O	N/C
CS8-40E-*	CS8C-40E-*	4	0
CS8-31Z-*	CS8C-31Z-*	3	1
CS8-22Z-*	CS8C-22Z-*	2	2

*Please add coil voltage when ordering.

Aux Blocks

Part Number	N.O.	N.C.
CS8-P02	0	2
CS8-P20	2	0
CS8-P11	1	1
CS8-P04	0	4
CS8-P22	2	2
CS8-P40	4	0

*Additional types available.

CS8 Surge Suppressor modules

Part Number	Link Type	Voltage
CRC8-50	RC	24 - 48VAC
CRC8-240	RC	110 - 280VAC
CRC8-480	RC	380 - 480VAC
CRD8-250	Diode	12 - 250VDC
CRV8-55	Varistor	12-55VAC/12-77VDC
CRV8-136	Varistor	56-136VAC/78-180VDC
CRV8-277	Varistor	137-277VAC/181-250VDC

Questions? Answers at...
 (866) CED-ELEV • (866) 233-3538
www.cedlevator.com

Telemacanique 3-Pole AC Contactors

Part Number*	Nema Equivalents	Max Inductive Current (Amps)	Maximum Horsepower Ratings							Aux	
			1-phase 50/60 Hz		3-phase 50/60 Hz			N/O	N/C		
			115/120V	230/240V	200/208V	220/240V	460/480V	575/600V			
LC1D09*	Size 00	9	0.5	1	2	2	5	7.5	1	1	
LC1D12*	"	12	1	2	3	3	7.5	10	1	1	
LC1D18*	Size 0	18	1	3	5	5	10	15	1	1	
LC1D25*	Size 1	25	2	3	7.5	7.5	15	20	1	1	
LC1D32*	"	32	2	5	10	10	20	30	1	1	
LC1D40*	"	40	3	5	10	10	30	30	1	1	
LC1D50*	Size 2	50	3	7.5	15	15	40	40	1	1	
LC1D65*	"	65	5	10	20	20	50	50	1	1	
LC1D80*	"	80	7.5	15	25	30	60	60	1	1	
LC1D115*	Size 3	115	-	-	30	40	75	100	0	0	
LC1D150*	Size 4	150	-	-	40	50	100	125	0	0	

*Please add coil voltage code when ordering.

Coil Voltage Codes

AC Volts (50/60 Hz)	24	42	48	110	115	120	127	208	220	230	240	277	380	400	415	440	480	575	600
LC1D09 to D32	B7	D7	E7	F7	FE7	G7	FC7	LE7	M7	P7	U7	W7	Q7	V7	N7	R7	T7	SC7	X7
LC1D40 to D150*	B7	D7	E7	F7	FE7	G7		L6	M7	P7	U7	W6	Q7	V7	N7	R7	T6	S6	X6

*with built-in surge suppression

DC Volts

Part Numbers	5	12	20	24	36	48	60	72	96	110	125	220	250	440
LP1D09 to D80			JD	BD	CD	ED	ND	SD	FD	GD	MD	UD	RD	
LP1D115 to D150*				BD	ED	ND	SD	FD	GD	MD	UD	RD		

*with built-in surge suppression

Auxiliary Contacts

Part Number	N.O.	N.C.	Mount
LADN10	1	0	Front
LADN01	0	1	Front
LADN11	1	1	Front
LADN20	2	0	Front
LADN02	0	2	Front
LADN22	2	2	Front
LADN13	1	3	Front
LADN31	3	1	Front
LADN40	4	0	Front
LADN04	0	4	Front
LAD8N11	1	1	Side
LAD8N20	2	0	Side
LAD8N02	0	2	Side

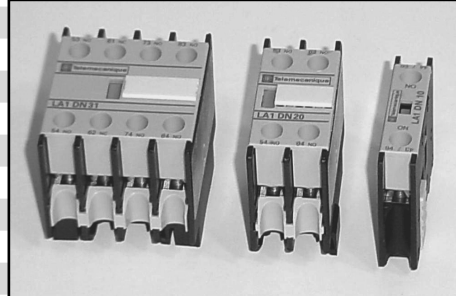

Questions? Answers at...
(866) CED-ELEV • (866) 233-3538
www.cedelevator.com

Telemecanique 3-Pole AC Reversing Contactors & Interlock Kits

Part Number*	Nema Equivalents	Max Inductive Current (Amps)	Maximum Horsepower Ratings							
			1-phase 50/60 Hz		3-phase 50/60 Hz				Aux	
			115/120V	230/240V	200/208V	220/240V	460/480V	575/600V	N/O	N/C
LC2D09*	Size 00	9	0.5	1	2	2	5	7.5	2	4
LC2D12*	"	12	1	2	3	3	7.5	10	2	4
LC2D18*	Size 0	18	1	3	5	5	10	15	2	4
LC2D25*	Size 1	25	2	3	7.5	7.5	15	20	2	4
LC2D32*	"	32	2	5	10	10	20	30	2	4
LC2D40*	"	40	3	5	10	10	30	30	2	4
LC2D50*	Size 2	50	3	7.5	15	15	40	40	2	4
LC2D65*	"	65	5	10	20	20	50	50	2	4
LC2D80*	"	80	7.5	15	25	30	60	60	2	4
LC2D115*	Size 3	115	-	-	30	40	75	100	0	0
LC2D150*	Size 4	150	-	-	40	50	100	125	0	0

*Please add coil voltage code when ordering.
See page 4.2 for selection table.



Interlock Kits for Field Assembly

Mechanical Interlock	Power Bus	
Part Number	Part Number	Used on Contactors
LAD9R1V	Included	LC1D09 to D38
LA9DR4002	LA9D6569	LC1D40 to D65
LA9DR4002	LA9D8069	LC1D80
LA9D11502	LA9D11569	LC1D115 to D150

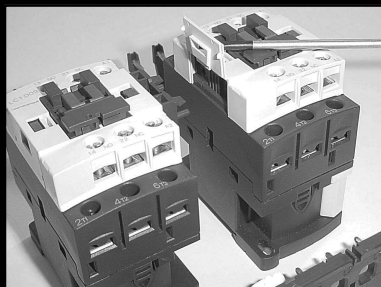
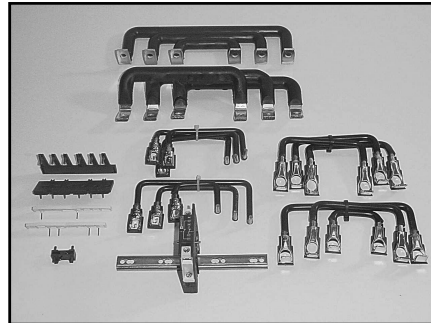

REMOVE SIDE COVER AND ATTACH INTERLOCK

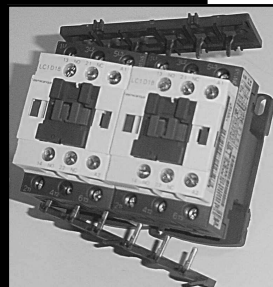

ATTACH POWER BUS

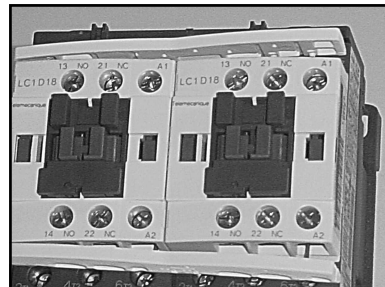

ATTACH CONTROL CIRCUIT BUS

Questions? Answers at...
 (866) CED-ELEV • (866) 233-3538
www.cedlevator.com

Telemecanique Overload Relays

Class 10 Bi-Metallic Overloads [2-10 sec. Trip]

Part Number*	Adjustable Trip Range (Amps)	For Use with Contactors
LRD01	0.10 to 0.16	D09 to D32
LRD02	0.16 to 0.25	D09 to D32
LRD03	0.25 to 0.40	D09 to D32
LRD04	0.40 to 0.63	D09 to D32
LRD05	0.63 to 1	D09 to D32
LRD06	1 to 1.7	D09 to D32
LRD07	1.6 to 2.5	D09 to D32
LRD08	2.5 to 4	D09 to D32
LRD10	4 to 6	D09 to D32
LRD12	5.5 to 8	D09 to D32
LRD14	7 to 10	D09 to D32
LRD16	9 to 13	D12 to D32
LRD21	12 to 18	D18 to D32
LRD22	16 to 24	D25 to D32
LRD32	23 to 32	D25 to D32
LRD3322	17 to 25	D40 to D80
LRD3353	23 to 32	D40 to D80
LRD3355	30 to 40	D40 to D80
LRD3357	37 to 50	D40 to D80
LRD3359	48 to 65	D50 to D80
LRD3361	55 to 70	D50 to D80
LRD3363	55 to 70	D65 to D80
LRD4365	63 to 80	D115 to D150
LRD4367	95 to 120	D115 to D150
LRD4369	110 to 140	D150

Class 20 Bi-Metallic Overloads [6-20 sec. Trip]

Part Number*	Adjustable Trip Range (Amps)	For Use with Contactors
LRD1508	2.5 to 4	D09 to D32
LRD1510	4 to 6	D09 to D32
LRD1512	5.5 to 8	D09 to D32
LRD1514	7 to 10	D09 to D32
LRD1516	9 to 13	D12 to D32
LRD1521	12 to 18	D18 to D32
LRD1522	17 to 25	D25 to D32
LR2D2553	23 to 32	D25 to D32
LR2D3522	17 to 25	D40 to D80
LR2D3553	23 to 32	D40 to D80
LR2D3555	30 to 40	D40 to D80
LR2D3557	37 to 50	D50 to D80
LR2D3559	48 to 65	D50 to D80
LR2D3561	55 to 70	D50 to D80
LR2D3563	63 to 80	D80
LR9D5567	60 to 100	D115 to D150
LR9D5569	90 to 150	D115 to D150



Panel Mount Adaptors

Part Number*	Fits Overload Type
LAD7B10	LRD01 to D35
LAD7B105	LRD15
LA7D1064	LR2D1
LA7D2064	LR2D2
LA7D3064	LR2D3

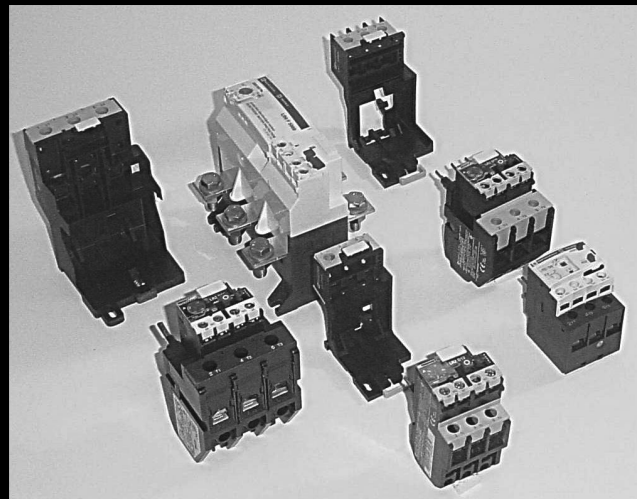

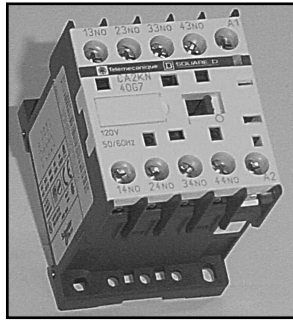

H-Line Relays

Part Number*	N.O.	N.C.	Coil Type
CA2KN40*	4	0	AC
CA2KN31*	3	1	AC
CA2KN22*	2	2	AC
CA3KN40*	4	0	DC
CA3KN31*	3	1	DC
CA3KN22*	2	2	DC

*Please add coil voltage code when ordering.

Auxiliary Contacts

Part Number*	N.O.	N.C.
LA1KN11	1	1
LA1KN20	2	0
LA1KN02	0	2
LA1KN22	2	2
LA1KN13	1	3
LA1KN31	3	1
LA1KN40	4	0
LA1KN04	0	4

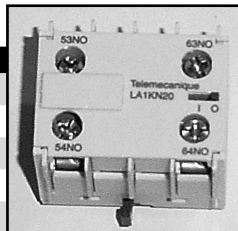

Electronic Timing Modules

Part Number	Voltage	Contacts
LA2KT2E	24 to 48 V AC/DC	1 x SPST
LA2KT2U	110 to 240 V AC	1 x SPST

AC 50/60 Hz	12	24	48	120	208	240	277	480	600		
Code	J7	B7	E7	G7	LE7	U7	W7	T7	X7		
DC	12	24	36	48	60	72	110	125	220	250	440
Code	JD	BD	CD	ED	ND	SD	FD	GD	MD	UD	RD

Telemecanique D-Line & K-Line Control Relays

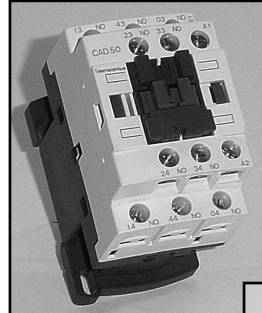

D-Line Relays

Part Number*	N.O.	N.C.
CAD50*	5	0
CAD32*	3	2

*Please add coil voltage code when ordering.

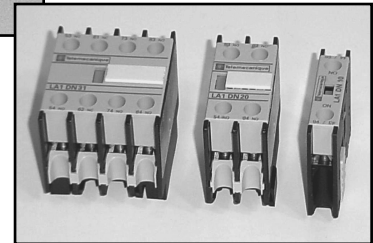

Auxiliary Contacts

Part Number	N.O.	N.C.	Mount
LADN10	1	0	Front
LADN01	0	1	Front
LADN11	1	1	Front
LADN20	2	0	Front
LADN02	0	2	Front
LADN22	2	2	Front
LADN13	1	3	Front
LADN31	3	1	Front
LADN40	4	0	Front
LADN04	0	4	Front
LAD8N11	1	1	Side
LAD8N20	2	0	Side
LAD8N02	0	2	Side

Pneumatic Timer Attachments

Part Number	Type	Time Range
LADT0	On-Delay	0.1 to 3 s
LADT2	On-Delay	0.1 to 30 s
LADT4	On-Delay	10 to 180 s
LADR0	Off-Delay	0.1 to 3 s
LADR2	Off-Delay	0.1 to 30 s
LADR4	Off-Delay	10 to 180 s

General Electric 3-Pole AC Contactors

CONTACTORS, STARTERS, RELAYS & TIMERS

Series C-2000 Non-Reversing Three Pole Contactors

Part Number*	Nema Equivalents	Maximum Horsepower Ratings			500V	Maximum Inductive (Amps)	Aux	
		200/230V	3-phase 50/60 Hz 380/400V	415/440V			N/O	N/C
CL00A310T*	Size 00	3	5.5	5.5	7.5	9	1	0
CL00A301T*	"	3	5.5	5.5	7.5	9	0	1
CL01A310T*	"	4	7.5	7.5	10	12	1	0
CL01A301T*	"	4	7.5	7.5	10	12	0	1
CL02A310T*	SIZE 0	5.5	10	10	13.5	18	1	0
CL02A301T*	"	5.5	10	10	13.5	18	0	1
CL03A310M*	SIZE 1	10	16	16	20	25	1	0
CL03A301M*	"	10	16	16	20	25	0	1
CL04A310M-*	"	12	22	22	25	32	1	0
CL04A301M*	"	12	22	22	25	32	0	1
CL45A310M*	SIZE 2	15	25	30	34	40	1	0
CL06A311M*	"	20	30	34	40	50	1	1
CL07A311M*	"	25	40	50	55	65	1	1
CL08A311M*	"	30	50	60	60	80	1	1
CL09A311M*	SIZE 3	34	60	68	75	95	1	1
CL10A311M*	"	40	75	75	88	110	1	1
CK75CA311*	SIZE 4	60	100	108	135	150	1	1
CK08CA311*	"	75	125	135	150	185	1	1
CK85BA311*	"	88	150	170	180	205	1	1

*Please add



Series C-2000 Aux Blocks

Part Number	N.O.	N.C.	Mount
BCLF10	1	0	Front
BCLF01	0	1	Front
BCLL11	1	1	Side
BCLL20	2	0	Side
BRLL20	2	0	Side, CK contactors
BRLL11	1	1	Side, CK contactors
BRLL02	0	2	Side, CK contactors

Voltage	Suffix
110 - 127	J
220 - 250	N
380 - 415	U
440 - 500	Y



Part Number	Type
BELA02	Mechanical / Electrical interlock, sizes CL00 - CL10
BTLF30C	Pneumatic timer attachment, on-delay 0.1 - 30 sec.
BTLF30D	Pneumatic timer attachment, off-delay 0.1 - 30 sec.
BSLV3G	Varistor surge suppressor module, 24 - 48V AC/DC
BSLV3K	Varistor surge suppressor module, 50 - 127V AC/DC
BSLV3R	Varistor surge suppressor module, 130 - 250V AC/DC

Questions? Answers at...
(866) CED-ELEV • (866) 233-3538
www.cedelevator.com

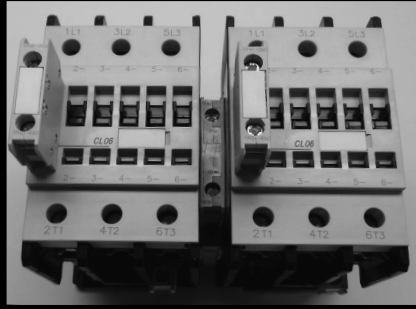

General Electric Reversing Contactors & Overload Relays

Series C-2000 Reversing Contactors

Part Number* AC Operated	Nema Equivalents	Maximum Horsepower Ratings				Maximum Inductive		Aux	
		220V	3-phase 50/60 Hz		575V	(Amps)	N/O	N/C	
LDR00A*	Size 00	3	3	5	7.5	10	2	2	
LDR01A*	"	3	3	7.5	10	13.8	2	2	
LDR02A*	SIZE 0	5	5	10	15	17.5	2	2	
LDR25A*	SIZE 1	5	7.5	15	15	22	2	2	
LDR04A*	"	10	10	20	25	32	2	2	
LDR45A*	"	10	10	25	25	34	2	2	
LER06A*	SIZE 2	15	15	30	40	48	2	2	
LER07A*	"	20	20	40	50	62	2	2	
LER08A*	"	20	25	50	60	68	2	2	
LER09A*	"	25	30	60	75	80	2	2	
LER10A*	SIZE 3	30	40	75	75	96	2	2	
KAR75C*	SIZE 4	40	50	100	100	140	2	2	

*Please add coil voltage code when ordering.

Part Number	Adjustable Trip Range		For Use with Contactors
	Type		
RT1N	8 to 12		CL00, CL01, CL02, CL25, CL04, CL45
RT1P	10 to 16		CL00, CL01, CL02, CL25, CL04, CL45
RT2B	14.5 to 19		CL06, CL07, CL08, CL09, CL10
RT2D	24 to 32		CL06, CL07, CL08, CL09, CL10
RT2E	30 to 43		CL06, CL07, CL08, CL09, CL10
RT2G	42 to 55		CL06, CL07, CL08, CL09, CL10
RT2H	54 to 65		CL07, CL08, CL09, CL10
RT2J	64 to 82		CL08, CL09, CL10
RT2L	78 to 97		CL10
RT2M	90 to 110		CL10

Coil Suffix

Voltage	Suffix
110 - 127	J
220 - 250	N
380 - 415	U
440 - 500	Y

Panel Mount Adapters

Part Number	Fits Overload Type
RTXP	RT1
RT2XP	RT2

Questions? Answers at...
(866) CED-ELEV • (866) 233-3538
www.cedlevator.com

General Electric Control Relays

Series C-2000 Control Relays - 10 amp a/c, 5 amp d/c continuous

Part Number		N/O	N/C
AC Operated	DC Operated		
RL4RA022T*	RL4RD022T*	2	2
RL4RA031T*	RL4RD031T*	3	1
RL4RA040T*	RL4RD040T*	4	0
RL4RA004T*	RL4RD004T*	0	4

*Please add coil voltage suffix when ordering.

Coil Suffix

Part Number	AC	DC
24	1	
48	F	
120	J	
208	L	
240	S	
480	U	
12		B
24		D
48		G
125		K
250		T



Series C-2000 Aux Blocks

Part Number	N/O	N/C	Mount
BCLF10	1	0	Front
BCLF01	0	1	Front
BCLL11	1	1	Side
BCLL20	2	0	Side
BRLL20	2	0	Side, CK contactors
BRLL11	1	1	Side, CK contactors
BRLL02	0	2	Side, CK contactors

*Please add coil voltage suffix when ordering.



Series C-2000 Accessories

Part Number	Type
BELA02	Mechanical / Electrical interlock, sizes CL00 - CL10
BTLF30C	Pneumatic timer attachment, on-delay 0.1 - 30 sec.
BTLF30D	Pneumatic timer attachment, off-delay 0.1 - 30 sec.
BSLV3G	Varistor surge suppressor module, 24 - 48V AC/DC
BSLV3K	Varistor surge suppressor module, 50 - 127V AC/DC
BSLV3R	Varistor surge suppressor module, 130 - 250V AC/DC

Questions? Answers at...
(866) CED-ELEV • (866) 233-3538
www.cedelevator.com



Siemens 3-Pole AC Contactors

Contactors

Part Number*	AC Operated	DC Operated	Nema Equivalents	Maximum Horsepower Ratings				Maximum		
				3-phase 50/60 Hz				Inductive (Amps)	Aux	
				200/230V	380/400V	415/440V	500V		N/O	N/C
3RT2016-1A_1	3RT2016-1B_1	Size 00	"	2	3	5	7.5	9	0	0
3RT2024-1A_1	3RT2024-1B_0	"	"	3	3	7.5	10	12	0	0
3RT2025-1A_0	3RT2025-1B_0	Size 0	"	5	5	10	15	17	0	0
3RT2026-1A_0	3RT2026-1B_0	Size 1	"	7.5	7.5	15	20	25	0	0
3RT2027-1A_0	3RT2027-1B_0	"	"	10	10	20	25	32	0	0
3RT2028-1A_0	3RT2028-1B_0	"	"	10	10	25	25	38	0	0
3RT2035-1A_0	3RT2035-1B_0	"	"	10	15	30	40	40	0	0
3RT2036-1A_0	3RT2036-1B_0	Size 2	"	15	15	40	50	50	0	0
3RT2044-1A_0	3RT2044-1B_0	"	"	20	25	50	60	65	0	0
3RT2045-1A_0	3RT2045-1B_0	"	"	25	30	60	75	80	0	0
3RT2046-1A_0	3RT2046-1B_0	Size 3	"	30	30	75	100	95	0	0
3RT1054-6A*6	3RT1054-6A_6	"	"	40	50	100	125	115	2	2
3RT1055-6A*6	3RT1055-6A_6	Size 4	"	50	60	125	150	150	2	2

Coil Suffix 3RT1054 & 56

Voltage	AC/DC Suffix
23 - 26	B3
110 - 127	F3
220 - 240	P3
440 - 480	R3
575 - 600	T3

Coil Suffix 3RT1026 - 46 (Other Voltages Available)

Voltage	AC	DC
24	C2	B4
110		F4
120	K6	
240	P6	
480	V6	
600	T6	

Questions? Answers at...
 (866) CED-ELEV • (866) 233-3538
www.cedlevator.com

Siemens Reversing Contactors

Sirius Reversing Contactors



Part Number*	Nema	Maximum Inductive Current Amps	Maximum Horsepower Ratings				Aux	
			Equivalents	200/208V	220/240V	3-phase 50/60 Hz	460/480V	575/600V
3RA2323-8XB30-1A*	Size 00	9	3	3	5	7.5	2	2
3RA2324-8XB30-1A*	"	12	3	3	7.5	10	2	2
3RA2325-8XB30-1A*	Size 0	17	5	5	10	15	2	2
3RA2326-8XB30-1A*	Size 1	25	5	7.5	15	15	2	2
3RA2334-8XB30-1A*	"	32	10	10	20	25	2	2
3RA2335-8XB30-1A*	"	40	10	10	25	25	2	2
3RA2344-8XB30-1A*	Size 2	65	15	15	30	40	2	2
3RA2345-8XB30-1A*	"	80	20	20	40	50	2	2
3RA2346-8XB30-1A*	Size 3	95	20	25	50	60	2	2

*Please add coil voltage code when ordering.



SIDE MOUNT AUX

Solid State Overload Relays - Class 10/20, Auto/Manual Reset

Voltage	Adjustable Trip Range (Amps)	Direct mount with Contactors
	3RB3123-4SB0	
3RB3123-4QB0	6 to 25	S0
3RB3133-4UW1	12.5 to 50	S2
3RB3143-4EB0	25 to 100	S3 with busbar
3RU2926-3AA001	S0	Separate Mount Adapter
3RU2936-3AA001	S2	Separate Mount Adapter
3RU2926-3AA001	S3	Separate Mount Adapter

Part Number	N/O	N/C	Mount
3RH2911-1HA11	1	1	Front, sizes S0-S2
3RH2911-1HA22	2	2	Front, sizes S0-S2
3RH2911-1HA31	3	1	Front, sizes S0-S2
3RH2911-1HA22	2	2	Front, sizes S0-S12
3RH2921-1DA20	2	0	Side, sizes S0-S2
3RH2921-1DA11	1	1	Side, sizes S0-S2
3RH2921-1EA11	1	1	Side, sizes S3-S12

*Additional types available.



Questions? Answers at...
(866) CED-ELEV • (866) 233-3538
www.cedelevator.com



Siemens Control Relays

Sirius Control Relays - 10 amp

Part Number	N/O	N/C
3RH2122-1__0	2	2
3RH2131-1__0	3	1
3RH2140-1__0	4	0

*Please add coil voltage suffix when ordering.

Coil Suffix

Voltage	AC
110-120	K6
220-240	P6

Sirius Control Relay Aux I

Part Number
3RH1911-1GA40
3RH1911-1GA31
3RH1911-1GA22
3RH1911-1GA13
3RH1911-1GA04

Class 40 Heavy Duty Contactors

Part Number*	Nema Sizes	Max Inductive Current (Amps)	Maximum Horsepower Ratings 3-phase 50/60 Hz			
			200/208V	220/240V	460/480V	575/600V
40BG32A	Size 00	9	1½	1½	2	2
40CP32A	Size 0	18	3	3	5	5
40DP32A	Size 1	27	7½	7½	10	10
40EP32A	Size 1¾	40	10	10	15	15
40FP32A	Size 2	45	10	15	25	25
40GP32A	Size 2½	60	15	20	30	30
40HP32A	Size 3	90	20	30	50	50
40IP32A	Size 3½	115	30	40	75	75
40JG32A	Size 4	135	40	50	100	100
40KG32A	Size 4½	210	50	75	150	150
40LG32A	Size 5	270	75	100	200	200
40MG32A	Size 6	540	150	200	400	400
40NG32A	Size 7	810		300	600	600
40PG32A	Size 8	1215		450	900	900

*Please add coil voltage code when ordering.

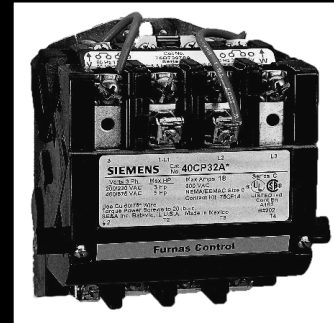

CONTACTORS, STARTERS, RELAYS & TIMERS

ESP200 Electronic Overload Relays

Part Number	Adjustable Trip Range (Amps)
48ATC3S00	3 to 20
48ATE3S00	10 to 40
48BTG3S00	25 to 100
48BTH3S00	50 to 200

*Additional sizes available

Coil Voltage Codes

AC Volts	Code
24 Separate Control	J
120 Separate Control	F
110-120 / 220-240	A
200-208	D
220-240	G
277	L
220-240 / 440-480	C
440-480	H
550-600	E



Questions? Answers at...
(866) CED-ELEV • (866) 233-3538
www.cedelevator.com

Siemens Hydraulic Elevator Starters



Part Number 120VAC Control Voltage	LINE Connected 200 - 460V H.P. Ratings			Rated Current (Amps)	Overload Range (Amps)	Current Limit Range (Amps)
	200V	230V	460V			
	72GG34AFP		5			
72HG34AFP	5	7.5	15	22	8...30	28...103
72JG34AFP	7.5	10	20	28	10...39	36...135
72KG34AFP	7.5	10	25	35	13...49	45...166
72LG34AFP	10	15	30	42	15...57	53...196
72MG34AFP	15	20	40	55	20...75	70...257
72NG34AFP	20	25	50	68	24...93	87...319
72PG34AFP	25	30	60	80	29...112	104...382
72RG32AFP	40	50		130	48...181	168...618

Part Number 120VAC Control Voltage	LINE Connected 460 - 575V H.P. Ratings		Rated Current (Amps)	Overload Range (Amps)	Current Limit Range (Amps)
	460V	575V			
	72XG34AFP	10			
72XG34AFP	15	20	22	8...30	28...103
72XG34AFP	20	25	28	10...39	36...135
72XG34AFP	25	30	35	13...49	45...166
72XG34AFP	30	40	42	15...57	53...196
72XG34AFP	40	50	55	20...75	70...257
72XG34AFP	50	60	68	24...93	87...319
72XG34AFP	60	75	80	29...112	104...382

Part Number 120VAC Control Voltage	DELTA Connected 200 - 460V H.P. Ratings			Rated Current (Amps)	Overload Range (Amps)	Current Limit Range (Amps)
	200V	230V	460V			
	72EG34AFP	5	7.5			
72GG34AFP	7.5	10	25	35	12...44	41...148
72HG34AFP	10	15	30	42	14...53	49...179
72JG34AFP	15	20	40	55	18...69	64...234
72KG34AFP	20	25	50	68	22...85	79...289
72LG34AFP	25	30	60	80	26...100	93...340
72MG34AFP	30	40	75	105	35...131	121...447
72NG34AFP	40	50	100	130	43...163	151...553
72PG34AFP	50	60	125	156	52...196	181...663
72RG32AFP	75	100		252	83...315	292...1071

Part Number 120VAC Control Voltage	DELTA Connected 460 - 575V H.P.		Rated Current (Amps)	Overload Ratings (Amps)	Current Limit Range (Amps)
	460V	575V			
	72XG34AFP	15			
72XG34AFP	25	30	35	12...44	41...148
72XG34AFP	30	40	42	14...53	49...179
72XG34AFP	40	50	55	18...69	64...234
72XG34AFP	50	60	68	22...85	79...289
72XG34AFP	60	75	80	26...100	93...340
72XG34AFP	75	100	105	35...131	121...447
72XG34AFP	100	125	130	43...163	151...553
72XG34AFP	125	150	156	52...196	181...663

Questions? Answers at...
(866) CED-ELEV • (866) 233-3538
www.cedlevator.com

CED Contactor Cross Reference Table



CONTACTORS, STARTERS, RELAYS & TIMERS

NEW Sprecher & Schuh "CA7" #	Obsolete Sprecher & Schuh "CA3" #	Obsolete G.E. Spectra 700 & CA5F #	G.E. 2000 Series #	Obsolete Siemens World Series #	Siemens Sirius Series #
CA7-9-10-120	CA3-9-10-120-N0	1 N.O. & 1 N.C. Aux Blocks as Listed	CL00A311TJ	3TF4022-0A	No Aux Blocks as Listed
CA7-9-10-120	CA3-9-10-120-N0	CR7CAA	CL00A311TJ	3TF4022-0AK6	3RT1023-1AK60
CA7-9-01-120	CA3-9-01-120-N0	CR7CAA	CL00A311TJ	3TF4022-0AK6	3RT1023-1AK60
CA7-9-10-220W	CA3-9-10-208-N0	CR7CAE	CL00A311TL	3TF4022-0AM2	3RT1023-1AM20
CA7-9-01-220W	CA3-9-01-208-N0	CR7CAE	CL00A311TL	3TF4022-0AM2	3RT1023-1AM20
CA7-9-10-220W	CA3-9-10-220-N0	CR7CAB	CL00A311TS	3TF4022-0AP6	3RT1023-1AN20
CA7-9-01-220W	CA3-9-01-220-N0	CR7CAB	CL00A311TS	3TF4022-0AP6	3RT1023-1AN20
CA7-9-10-480	CA3-9-10-480-N0	CR7CAC	CL00A311TU	3TF4022-0AV0	3RT1023-1AV60
CA7-9-01-480	CA3-9-01-480-N0	CR7CAC	CL00A311TU	3TF4022-0AV0	3RT1023-1AV60
CA7-12-10-120	CA3-12-10-120-N0	CR7CBA	CL01A311TJ	3TF4122-0AK6	3RT1024-1AK60
CA7-12-01-120	CA3-12-01-120-N0	CR7CBA	CL01A311TJ	3TF4122-0AK6	3RT1024-1AK60
CA7-12-10-220W	CA3-12-10-208-N0	CR7CBE	CL01A311TL	3TF4122-0AM2	3RT1024-1AM20
CA7-12-01-220W	CA3-12-01-208-N0	CR7CBE	CL01A311TL	3TF4122-0AM2	3RT1024-1AM20
CA7-12-10-220W	CA3-12-10-220-N0	CR7CBB	CL01A311TS	3TF4122-0AP6	3RT1024-1AN20
CA7-12-01-220W	CA3-12-01-220-N0	CR7CBB	CL01A311TS	3TF4122-0AP6	3RT1024-1AN20
CA7-12-10-480	CA3-12-10-480-N0	CR7CBC	CL01A311TU	3TF4122-0AV0	3RT1024-1AV60
CA7-12-01-480	CA3-12-01-480-N0	CR7CBC	CL01A311TU	3TF4122-0AV0	3RT1024-1AV60
CA7-16-10-120	CA3-16-10-120-N0	CR7CCA	CL02A311TJ	3TF4222-0AK6	3RT1025-1AK60
CA7-16-01-120	CA3-16-01-120-N0	CR7CCA	CL02A311TJ	3TF4222-0AK6	3RT1025-1AK60
CA7-16-10-220W	CA3-16-10-208-N0	CR7CCE	CL02A311TL	3TF4222-0AM2	3RT1025-1AM20
CA7-16-01-220W	CA3-16-01-208-N0	CR7CCE	CL02A311TL	3TF4222-0AM2	3RT1025-1AM20
CA7-16-10-220W	CA3-16-10-220-N0	CR7CCB	CL02A311TS	3TF4222-0AP6	3RT1025-1AN20
CA7-16-01-220W	CA3-16-01-220-N0	CR7CCB	CL02A311TS	3TF4222-0AP6	3RT1025-1AN20
CA7-16-10-480	CA3-16-10-480-N0	CR7CCC	CL02A311TU	3TF4222-0AV0	3RT1025-1AV60
CA7-16-01-480	CA3-16-01-480-N0	CR7CCC	CL02A311TU	3TF4222-0AV0	3RT1025-1AV60
CA7-23-10-120	CA3-23-10-120-N0	CR7CEA	CL25A311TJ	3TF4322-0AK6	3RT1026-1AK60
CA7-23-01-120	CA3-23-01-120-N0	CR7CEA	CL25A311TJ	3TF4322-0AK6	3RT1026-1AK60
CA7-23-10-220W	CA3-23-10-208-N0	CR7CEE	CL25A311TL	3TF4322-0AM2	3RT1026-1AM20
CA7-23-01-220W	CA3-23-01-208-N0	CR7CEE	CL25A311TL	3TF4322-0AM2	3RT1026-1AM20
CA7-23-10-220W	CA3-23-10-220-N0	CR7CEB	CL25A311TS	3TF4322-0AP6	3RT1026-1AN20
CA7-23-01-220W	CA3-23-01-220-N0	CR7CEB	CL25A311TS	3TF4322-0AP6	3RT1026-1AN20
CA7-23-10-480	CA3-23-10-480-N0	CR7CEC	CL25A311TU	3TF4322-0AV0	3RT1026-1AV60
CA7-23-01-480	CA3-23-01-480-N0	CR7CEC	CL25A311TU	3TF4322-0AV0	3RT1026-1AV60
CA7-30-00-120	CA3-30-10-120-N0	CR7CFA	CL04A311MJ*	3TF4422-0AK6	3RT1033-1AK60
CA7-30-00-120	CA3-30-01-120-N0	CR7CFA	CL04A311MJ*	3TF4422-0AK6	3RT1033-1AK60
CA7-30-00-220W	CA3-30-10-208-N0	CR7CFE	CL04A311ML*	3TF4422-0AM2	3RT1033-1AM20
CA7-30-00-220W	CA3-30-01-208-N0	CR7CFE	CL04A311ML*	3TF4422-0AM2	3RT1033-1AM20
CA7-30-00-220W	CA3-30-10-220-N0	CR7CFB	CL04A311MS*	3TF4422-0AP6	3RT1033-1AN20
CA7-30-00-220W	CA3-30-01-220-N0	CR7CFB	CL04A311MS*	3TF4422-0AP6	3RT1033-1AN20
CA7-30-00-480	CA3-30-10-480-N0	CR7CFC	CL04A311MU*	3TF4422-0AV0	3RT1033-1AV60
CA7-30-00-480	CA3-30-01-480-N0	CR7CFC	CL04A311MU*	3TF4422-0AV0	3RT1033-1AV60
CA7-37-00-120	CA3-37-120-N0	CR7CGA	CL45A311MJ*	3TF4522-0AK6	3RT1034-1AK60
CA7-37-00-220W	CA3-37-208-N0	CR7CGE	CL45A311ML*	3TF4522-0AM2	3RT1034-1AM20
CA7-37-00-220W	CA3-37-220-N0	CR7CGB	CL45A311MS*	3TF4522-0AP6	3RT1034-1AN20
CA7-37-00-480	CA3-37-480-N0	CR7CGC	CL45A311MU*	3TF4522-0AV0	3RT1034-1AV60
CA7-43-00-120	CA3-43-120-N0	CR7CHA	CL06A311MJ*	3TF4622-0AK6	3RT1035-1AK60
CA7-43-00-220W	CA3-43-208-N0	CR7CHE	CL06A311ML*	3TF4622-0AM2	3RT1035-1AM20
CA7-43-00-220W	CA3-43-220-N0	CR7CHB	CL06A311MS*	3TF4622-0AP6	3RT1035-1AN20
CA7-43-00-480	CA3-43-480-N0	CR7CHC	CL06A311MU*	3TF4622-0AV0	3RT1035-1AV60
CA7-60-00-120	CA3-60-120-N0	CR7CJA	CL07A311MJ*	3TF4722-0AK6	3RT1036-1AK60
CA7-60-00-220W	CA3-60-208-N0	CR7CJE	CL07A311ML*	3TF4722-0AM2	3RT1036-1AM20
CA7-60-00-220W	CA3-60-220-N0	CR7CJB	CL07A311MS*	3TF4722-0AP6	3RT1036-1AN20
CA7-60-00-480	CA3-60-480-N0	CR7CJC	CL07A311MU*	3TF4722-0AV0	3RT1036-1AV60
CA7-72-00-120	CA3-72-120-N0	CR7CKA	CL08A311MJ		3RT1044-1AK60
CA7-72-00-220W	CA3-72-208-N0	CR7CKE	CL08A311ML		3RT1044-1AM20
CA7-72-00-220W	CA3-72-220-N0	CR7CKB	CL08A311MS		3RT1044-1AN20
CA7-72-00-480	CA3-72-480-N0	CR7CKC	CL08A311MU		3RT1044-1AV60
CA7-85-00-120			CL09A311MJ	3TF4822-0AK6	3RT1045-1AK60
CA7-85-00-220W			CL09A311ML	3TF4822-0AM2	3RT1045-1AM20
CA7-85-00-220W			CL09A311MS	3TF4822-0AP6	3RT1045-1AN20
CA7-85-00-480			CL09A311MU	3TF4822-0AV0	3RT1045-1AV60
CA6-105-EI-11-120	CA1-60-120-N0	CA5F2A22110B	CL10A311MJ	3TF5022-0AK6	
CA6-105-EI-11-208	CA1-60-208-N0	CA5F2A22208S	CL10A311ML	3TF5022-0AM2	
CA6-105-EI-11-220	CA1-60-220-N0	CA5F2A22220B	CL10A311MS	3TF5022-0AP6	
CA6-105-EI-11-480	CA1-60-480-N0	CA5F2A22480S	CL10A311MU	3TF5022-0AV0	
CA6-140-EI-11-120	CA1-100-120-N0	CA5F3A22110B	CK75CE311J	3TF5122-0AK6	3RT1055-6AF36
CA6-140-EI-11-208	CA1-100-208-N0	CA5F3A22208S	CK75CE311L	3TF5122-0AM2	3RT1055-6AM36
CA6-140-EI-11-220	CA1-100-220-N0	CA5F3A22220B	CK75CE311N	3TF5122-0AP6	3RT1055-6AM36
CA6-140-EI-11-480	CA1-100-480-N0	CA5F3A22480S	CK75CE311Y	3TF5122-0AV0	3RT1055-6AR36

Note:
* If you are using an S&S contactor to replace this G.E. contactor in an application where the motor voltage is 208 VAC, go up one size on the S&S contactor.

Questions? Answers at...
(866) CED-ELEV • (866) 233-3538
www.cedelevator.com

CED Contactor Cross Reference Table

NEW Sprecher & Schuh "CA7" #	Cutler-Hammer Freedom Series I.E.C. #	Furnas	Obsolete Telemecanique D-Line #	Telemecanique TeSys #
CA7-9-10-120	No Aux Block as Listed	1 N.O. Aux Block as Listed	LC1D0910-G6	1 N.O. & N.C. Aux Blocks as Listed
CA7-9-10-120	CE15BNS3AB	40BG32AF or (AA)	LC1D0910G6	LC1D09G7
CA7-9-01-120	CE15BNS3AB		LC1D0901G6	LC1D09G7
CA7-9-10-220W	CE15BNS3EB	40BG32AD	LC1D0910L6	LC1D09LE7
CA7-9-01-220W	CE15BNS3EB		LC1D0901L6	LC1D09LE7
CA7-9-10-220W	CE15BNS3BB	40BG32AG or (AA)	LC1D0910M6	LC1D09M7
CA7-9-01-220W	CE15BNS3BB		LC1D0901M6	LC1D09M7
CA7-9-10-480	CE15BNS3CB	40BG32AH	LC1D0910T6	LC1D09T7
CA7-9-01-480	CE15BNS3CB		LC1D0901T6	LC1D09T7
CA7-12-10-120	CE15CNS3AB		LC1D1210G6	LC1D12G7
CA7-12-01-120	CE15CNS3AB		LC1D1201G6	LC1D12G7
CA7-12-10-220W	CE15CNS3EB		LC1D1210L6	LC1D12LE7
CA7-12-01-220W	CE15CNS3EB		LC1D1201L6	LC1D12LE7
CA7-12-10-220W	CE15CNS3BB		LC1D1210M6	LC1D12M7
CA7-12-01-220W	CE15CNS3BB		LC1D1201M6	LC1D12M7
CA7-12-10-480	CE15CNS3CB		LC1D1210T6	LC1D12T7
CA7-12-01-480	CE15CNS3CB		LC1D1201T6	LC1D12T7
CA7-16-10-120	CE15DNS3AB	40CP32AF or (AA)	LC1D1810G6	LC1D18G7
CA7-16-01-120	CE15DNS3AB		LC1D1801G6	LC1D18G7
CA7-16-10-220W	CE15DNS3EB	40CP32AD	LC1D1810L6	LC1D18LE7
CA7-16-01-220W	CE15DNS3EB		LC1D1801L6	LC1D18LE7
CA7-16-10-220W	CE15DNS3BB	40CP32AG or (AA)	LC1D1810M6	LC1D18M7
CA7-16-01-220W	CE15DNS3BB		LC1D1801M6	LC1D18M7
CA7-16-10-480	CE15DNS3CB	40CP32AH	LC1D1810T6	LC1D18T7
CA7-16-01-480	CE15DNS3CB		LC1D1801T6	LC1D18T7
CA7-23-10-120	CE15ENS3AB		LC1D2510G6	LC1D25G7
CA7-23-01-120	CE15ENS3AB		LC1D2501G6	LC1D25G7
CA7-23-10-220W	CE15ENS3EB		LC1D2510L6	LC1D25LE7
CA7-23-01-220W	CE15ENS3EB		LC1D2501L6	LC1D25LE7
CA7-23-10-220W	CE15ENS3BB		LC1D2510M6	LC1D25M7
CA7-23-01-220W	CE15ENS3BB		LC1D2501M6	LC1D25M7
CA7-23-10-480	CE15ENS3CB		LC1D2510T6	LC1D25T7
CA7-23-01-480	CE15ENS3CB		LC1D2501T6	LC1D25T7
CA7-30-00-120	CE15FNS3AB	40DP32AF or (AA)	LC1D3210G6	LC1D32G7
CA7-30-00-120	CE15FNS3AB		LC1D3201G6	LC1D32G7
CA7-30-00-220W	CE15FNS3EB	40DP32AD	LC1D3210L6	LC1D32LE7
CA7-30-00-220W	CE15FNS3EB		LC1D3201L6	LC1D32LE7
CA7-30-00-220W	CE15FNS3BB	40DP32AG or (AA)	LC1D3210M6	LC1D32M7
CA7-30-00-220W	CE15FNS3BB		LC1D3201M6	LC1D32M7
CA7-30-00-480	CE15FNS3CB	40DP32AH	LC1D3210T6	LC1D32T7
CA7-30-00-480	CE15FNS3CB		LC1D3201T6	LC1D32T7
CA7-37-00-120	CE15GNS3AB	40EP32AF or (AA)	LC1D4011G6	LC1D40G7
CA7-37-00-220W	CE15GNS3EB	40EP32AD	LC1D4011L6	LC1D40L7
CA7-37-00-220W	CE15GNS3BB	40EP32AG or (AA)	LC1D4011M6	LC1D40M7
CA7-37-00-480	CE15GNS3CB	40EP32AH	LC1D4011T6	LC1D40T7
CA7-43-00-120	CE15HNS3AB	40FP32AF or (AA)	LC1D5011G6	LC1D50G7
CA7-43-00-220W	CE15HNS3EB	40FP32AD	LC1D5011L6	LC1D50L7
CA7-43-00-220W	CE15HNS3BB	40FP32AG or (AA)	LC1D5011M6	LC1D50M7
CA7-43-00-480	CE15HNS3CB	40FP32AH	LC1D5011T6	LC1D50T7
CA7-60-00-120	CE15JNS3AB	40GP32AF or (AA)	LC1D6511G6	LC1D65G7
CA7-60-00-220W	CE15JNS3EB	40GP32AD	LC1D6511L6	LC1D65L7
CA7-60-00-220W	CE15JNS3BB	40GP32AG or (AA)	LC1D6511M6	LC1D65M7
CA7-60-00-480	CE15JNS3CB	40GP32AH	LC1D6511T6	LC1D65T7
CA7-72-00-120	CE15KNS3AB			
CA7-72-00-220W	CE15KNS3EB			
CA7-72-00-220W	CE15KNS3BB			
CA7-72-00-480	CE15KNS3CB			
CA7-85-00-120	CE15LN3A	40HP32AF or (AA)	LC1D8011G6	LC1D80G7
CA7-85-00-220W	CE15LN3E	40HP32AD	LC1D8011L6	LC1D80L7
CA7-85-00-220W	CE15LN3B	40HP32AG or (AA)	LC1D8011M6	LC1D80M7
CA7-85-00-480	CE15LN3C	40HP32AH	LC1D8011T6	LC1D80T7
CA6-105-EI-11-120	CE15MN3A	40IP32AF or (AA)	LC1F15G6 or LC1D11500G6	LC1D115G7
CA6-105-EI-11-208	CE15MN3E	40IP32AD	LC1F15L6 or LC1D11500L6	LC1D115L7
CA6-105-EI-11-220	CE15MN3B	40IP32AG or (AA)	LC1F15M6 or LC1D11500M6	LC1D115M7
CA6-105-EI-11-480	CE15MN3C	40IP32AH	LC1F15T6 or LC1D11500T6	LC1D115T7
CA6-140-EI-11-120	CE15NN3A	40JG32AF or (AA)	LC1F150G6 or LC1D15000G6	LC1D150G7
CA6-140-EI-11-208	CE15NN3E	40JG32AD	LC1F150L6 or LC1D15000L6	LC1D150L7
CA6-140-EI-11-220	CE15NN3B	40JG32AG or (AA)	LC1F150M6 or LC1D15000M6	LC1D150M7
CA6-140-EI-11-480	CE15NN3C	40JG32AH	LC1F150T6 or LC1D15000T6	LC1D150T7

Notes: If you are using an S&S contactor to replace this G.E. contactor in an application where the motor voltage is 208 VAC, go up one size on the S&S contactor.
Aux block configurations differ slightly between mfrs, but nomenclature is common with 1st character indicating N.O. & 2nd character indicating N.C. See examples to determine part# placement per mfr. Configurations in chart are the most commonly found in elevator systems.

ABB 3-Pole AC/DC Operated Contactors

ABB AF Series 3-Pole Contactors with 100...250V AC/DC electronic coils [other coil voltages available, see table]

Part Number	Maximum Horsepower Ratings 3-Phase 50/60 Hz				Maximum Inductive (Amps)	Aux	
	200/208V	220/240V	440/480V	550/600V		N/O	N/C
AF09-30-10-13	2	2	5	7.5	9	1	0
AF09-30-01-13	2	2	5	7.5	9	0	1
AF12-30-10-13	3	3	7.5	10	12	1	0
AF12-30-01-13	3	3	7.5	10	12	0	1
AF16-30-10-13	5	5	10	15	16	1	0
AF16-30-01-13	5	5	10	15	16	0	1
AF26-30-10-13	7.5	7.5	15	20	26	1	0
AF26-30-01-13	7.5	7.5	15	20	26	0	1
AF30-30-10-13	10	10	20	25	30	1	0
AF30-30-01-13	10	10	20	25	30	0	1
AF38-30-10-13	10	10	20	25	38	1	0
AF38-30-01-13	10	10	20	25	38	0	1
AF40-30-11-13	10	15	30	10	40	1	1
AF52-30-11-13	15	20	40	50	52	1	1
AF65-30-11-13	20	25	50	60	65	1	1
AF80-30-11-13	25	30	60	75	80	1	1
AF96-30-11-13	30	30	60	75	96	1	1
AF116-30-11-13	30	40	75	100	116	1	1
AF146-30-11-13	40	50	100	125	146	1	1
AF190-30-11-13	50	60	125	150	190	1	1
AF205-30-11-13	60	75	150	200	205	1	1
AF265-30-11-13	75	100	200	250	265	1	1
AF305-30-11-13	100	125	250	300	305	1	1
AF370-30-11-13	125	150	300	350	370	1	1
AF400-30-11-13	125	150	350	400	400	1	1
AF460-30-11-13	150	200	400	500	460	1	1
AF580-30-11-13	200	250	500	600	580	1	1

Additional Coil Voltages Available Substitute (13) with one of the following

Voltage Range	Voltage Code
24...60	41
48...130	12
200...500	14



Questions? Answers at...
(866) CED-ELEV • (866) 233-3538
www.cedelevator.com

ABB 4-Pole AC/DC Operated Contactors & Aux Contacts

ABB AF Series 4-Pole Contactors with 100...250V AC/DC electronic coils

[other coil voltages available, see table]

Part Number 2-Pole (2 N.O)	Maximum Horsepower Ratings				Maximum Inductive		Power Poles		Aux	
	200/208V	3-Phase 50/60 Hz		550/600V	(Amps)	N/O	N/C	N/O	N/C	
		220/240V	440/480V							
AF09-40-00-13	2	2	5	7.5	9	4	0	0	0	
AF09-22-00-13	2	2	5	7.5	9	2	2	0	1	
AF16-40-00-13	3	3	7.5	10	12	4	0	1	0	
AF16-22-00-13	5	5	10	15	16	2	2	0	1	
AF26-40-00-13	7.5	7.5	15	20	26	4	0	1	0	
AF26-22-00-13	7.5	7.5	15	20	26	2	2	0	1	
AF38-40-00-13	10	10	20	25	38	4	0	1	0	
AF38-22-00-13	10	10	20	25	38	2	2	0	1	



Additional Coil Voltages Available

Substitute (13) with one of the following

Voltage Range	Voltage Code
24...60	41
48...130	12
200...500	14



Part Number	N/O	N/C	Mount
CA4-10	1	0	Front
CA4-01	0	1	Front
CA4-22E	2	2	Front
CA4-31E	3	1	Front
CA4-40E	4	0	Front
CAL19-11	1	1	Side, AF116...AF370 Contactors
CAL19-11B	1	1	Side (outside mount), AF116...AF370 Contactors
CAL18-11	1	1	Side, AF400...AF2650 Contactors
CAL18-11B	1	1	Side (outside mount), AF400...AF2650 Contactors



ABB AF Series Mechanical Interlocks

Part Number	Type
VM4	Mechanical interlock, AF09...AF48
VM96-4	Mechanical interlock, AF40...AF96

ABB Reversing/Wye-Delta Contactors & Overload Relays

CONTACTORS, STARTERS, RELAYS & TIMERS

ABB AF Series Reversing Contactors with 100...250V AC/DC electronic coils

[other coil voltages available, see table]

Maximum Horsepower Ratings											
Part Number	Inductive Current Rating AC Amps Operated (3-Wire)	Wye-Delta Connected - 6 Wire									
		Line Connected - 3 Wire				* Supplied as a Reversing contactor, remove the load side power connector for wye-delta use				Aux	
		3-Phase 50/60 Hz				3-Phase 50/60 Hz				N/O	N/C
		220V	230V	460V	575V	220V	230V	460V	575V		
AF09R-30-22-13	9	2	2	5	7.5	5	5	10	10	2	2
AF12R-30-22-13	12	3	3	7.5	10	5	7.5	15	15	2	2
AF16R-22-30-13	16	5	5	10	15	7.5	10	20	20	2	2
AF26R-30-22-13	23	7.5	7.5	15	20	7.5	10	25	25	2	2
AF30R-230-22-13	30	10	10	20	25	10	15	30	30	2	2
AF38R-30-22-13	38	10	10	20	25	15	20	40	40	2	2
AF40R-30-22-13	40	10	15	30	10	20	25	50	50	2	2
AF52R-30-22-13	52	15	20	40	50	25	30	60	60	2	2
AF65R-30-22-13	65	20	25	50	60	30	40	75	75	2	2
AF80R-30-22-13	80	25	30	60	75	40	50	100	100	2	2
AF96R-30-22-13	96	30	30	60	75	50	60	125	125	2	2

Additional Coil Voltages Available Substitute (13) with one of the following

Voltage Range	Voltage Code
24...60	41
48...130	12
200...500	14

ABB Electronic Overload Relays - Auto/Manual Reset, Class 10, 20 & 30 selectable trip

Part Number	Adjustable Trip Range (Amps)	For Use with Contactors
EF19-18.9	5.7...18.9	AF09, AF12, AF16, AF26, AF30 & AF38
EF45-30	9...30	AF09, AF12, AF16, AF26, AF30 & AF38
EF45-45	15...45	AF09, AF12, AF16, AF26, AF30 & AF38
EF65-70	25...70	AF40, AF52 & AF65
EF96-100	36...100	AF80 & AF96
EF146-150	54...150	AF116 & AF146
EF205-210	63...210	AF190 & AF205
EF370-380	115...380	AF265, AF305 & AF370

*Additional sizes available



Questions? Answers at...
(866) CED-ELEV • (866) 233-3538
www.cedelevator.com

ABB
DC Drive Contactors



Part Number* 2-Pole (2 N.O)	Part Number* 3-Pole (2N.O.& 1 N.C.)	Maximum Amp Ratings		Thermal	
		Make 300 VDC	Break 160 VDC	Amp Rating 600 VDC	Aux N/O N/C
EHDB220C2P-1L	EHDB220C-1L	450	285	220	1 1
EHDB280C2P-1L	EHDB280C-1L	565	363	280	1 1
EHDB360C2P-1L	EHDB360C-1L	728	472	380	1 1
EHDB520C2P-1L	EHDB520C-1L	1040	680	520	1 1
EHDB650C2P-1L	EHDB650C-1L	1300	850	650	1 1
EHDB800C2P-1L	EHDB800C-1L	1600	1050	800	1 1
EHDB960C2P-1L	EHDB960C-1L	1920	1250	950	1 1

*Please add coil voltage code when ordering.

Coil Voltage Codes

	24	48	110	120	125	208	220	240	277	380	415	440	480	500	600
60 Hz	F	G		1		B	2	2	C			3	4		6
50 Hz	N		1				J			3	4				6
DC	Y	W	P		Q		R					T			



Auxiliary Contacts

Part Number	Terminal Marking	
	N.O.	N.C.
CAL16-11A	1 1	13,14 21,22
CAL16-11B	1 1	43,44 31,32
CAL16-11C	1 1	53,54 61,62
CAL16-11D	1 1	83,84 71,72
CAL16-11E	1* 1*	47,48 35,36

*Late break, early make.

**ABB Type DA 60amp Drive Contactors - for use with solid state drives
2 & 3 Pole - 500V H.O. Ratings with 160V H.C. Dynamic Breaking Rating**

Make 300 VDC	Brake 160 VDC	Maximum Amp Ratings N.C. Contact		Auxiliary Contacts	
		N.O.	N.C.	Included	
				2-Pole (N.O.) Part Number	3-Pole (2 N.O. & 1 N.C.) Part Number
90	55	2	1	DA75-21-21-84	
		1	1	DA75-20-11-84	

DA Series Auxiliary Contacts

Part Number	N.O.	N.C.
CA5-10	1	0
CA5-01	0	1
CAL5-11	1	1

3 Pole - 500V H.O. Ratings with 300V H.C. Dynamic Breaking Rating

Make 300 VDC	Brake 160 VDC	Maximum Amp Ratings N.C. Contact		Auxiliary Contacts	
		N.O.	N.C.	Included	
				3-Pole (2 N.O. & 1 N.C.) Part Number	
90	55	1	1	DA75-21A-11-84	

Definite Purpose Replacement Contactors

CONTACTORS, STARTERS, RELAYS & TIMERS

Item Description	CED Item #	Obsolete Fumas	Figure
DEFINITE PURPOSE CONTACTOR, 2-POLE 20 AMP (30A RESISTIVE), 120VAC COIL	8910DP12V02	41NB20AFM	A
DEFINITE PURPOSE CONTACTOR, 2-POLE 25 AMP (35 A RESISTIVE), 120VAC COIL	8910DPA22V02	42BE35AF	A
DEFINITE PURPOSE CONTACTOR, 3-POLE 25 AMP (35 A RESISTIVE), 120VAC COIL	8910DPA23V02	41NB30AFM	B
DEFINITE PURPOSE CONTACTOR, 4-POLE 25 AMP (35 A RESISTIVE), 120VAC COIL	8910DPA24V02	42BE25AF	C
DEFINITE PURPOSE CONTACTOR, 2-POLE 30 AMP (40 A RESISTIVE), 120VAC COIL	8910DPA32V02	42CE15AF	D
DEFINITE PURPOSE CONTACTOR, 3-POLE 30 AMP (40 A RESISTIVE), 120VAC COIL	8910DPA33V02	42CE35AF	E
DEFINITE PURPOSE CONTACTOR, 3-POLE 30 AMP (40 A RESISTIVE), 208/240V COIL	8910DPA33V09	42CE35AG	E
DEFINITE PURPOSE CONTACTOR, 3-POLE 30 AMP (40 A RESISTIVE), 24VAC COIL	8910DPA33V14	42CE35AJ	E
DEFINITE PURPOSE CONTACTOR, 4-POLE 30 AMP (40 A RESISTIVE), 120VAC COIL	8910DPA34V02	42CE25AF	F
DEFINITE PURPOSE CONTACTOR, 3-POLE 40 AMP (50 A RESISTIVE), 120VAC COIL	8910DPA43V02	42DE35AF	G
DEFINITE PURPOSE CONTACTOR, 3-POLE 40 AMP (50 A RESISTIVE), 208/240V COIL	8910DPA43V09	42DE35AG	G
DEFINITE PURPOSE CONTACTOR, 3-POLE 40 AMP (50 A RESISTIVE), 24VAC COIL	8910DPA43V14	42DE35AJ	G
DEFINITE PURPOSE CONTACTOR, 4-POLE 40 AMP (50 A RESISTIVE), 120VAC COIL	8910DPA44V02		H
DEFINITE PURPOSE CONTACTOR, 3-POLE 50 AMP (62 A RESISTIVE), 24VAC COIL	8910DPA53V02	42EE35AJ	I
DEFINITE PURPOSE CONTACTOR, 3-POLE 60 AMP (75 A RESISTIVE), 120VAC COIL	8910DPA63V02	42FE35AF	J
DEFINITE PURPOSE CONTACTOR, 3-POLE 60 AMP (75 A RESISTIVE), 208/240V COIL	8910DPA63V09	42FE35AG	J

* Additional sizes and coil voltages are available on request

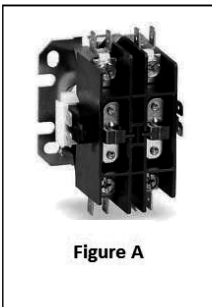

Figure A

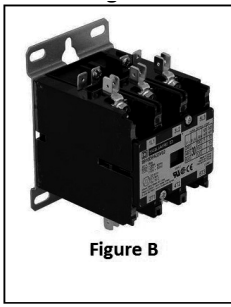

Figure B

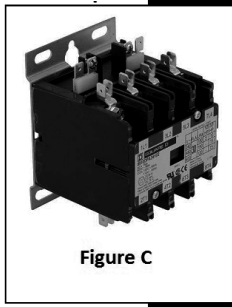

Figure C

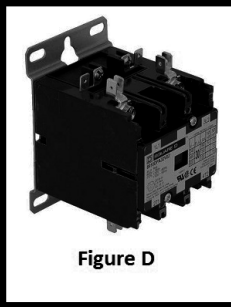

Figure D



Figure E



Figure F

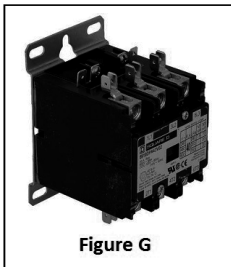

Figure G

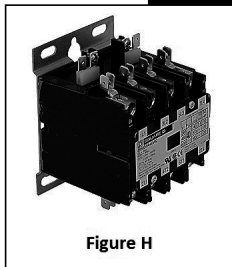

Figure H



Figure I



Figure J

Questions? Answers at...
 (866) CED-ELEV • (866) 233-3538
www.cedelevator.com

RELAY PART NUMBER KEY
OPR 2PDT B 120AC

Relay Type	Contacts	Options	Coil
OPR	2PDT	B	120AC

Relay Part Numbering System & Open Power Relays

Relay Part Numbering System

The relays offered in this catalog are manufactured by a variety of manufacturers including Magnecraft & Struthers-Dunn (MSD), Cyberdyn Systems, Potter & Brumfield, Idec, Line Electric, Square D, and others. The part numbers have been created to simplify ordering. All relays are UL & CSA listed.

Open Power Relay Types

OPR = Open Power Relay

Contact Configuration

2PST = Two Pole Single Throw

2PDT = Two Pole Double Throw

4PDT = Four Pole Double Throw

Options

A = (1) SPDT Aux Contact

B = Magnetic Blowout

Open Power Relays

Please see opposite page for product specifications.

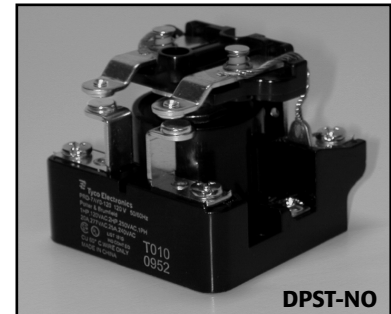
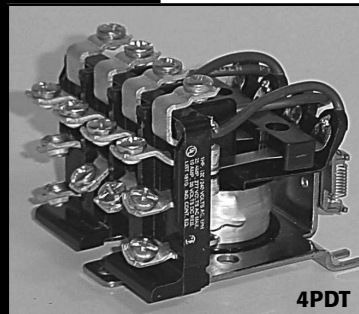
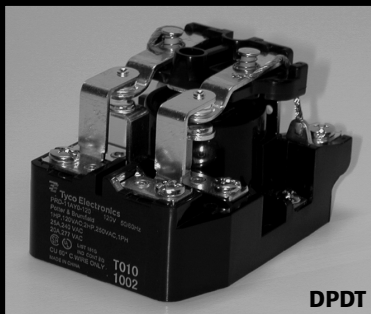

Open Power Relays



Please see opposite page for product representations.

CED Part Number	Dover Number	Dover Print	Mont-gomery	Westing-house	Contacts	Mag. Blowout	Coil Number	PRD Number	PR Number	P&B Number	MSD Number
OPR2PST6AC					DPST-NO		6AC			PRD7AY06	199AX-6
OPR2PST12AC				H3088H03	DPST-NO		12AC			PRD7AY012	199AX-7
OPR2PST24AC					DPST-NO		24AC			PRD7AY024	W199AX-8
OPR2PST120AC	9713256	71979		H3088H013	DPST-NO		120AC	PRD60399	PR2819	PRD7AY0120	W199AX-9
OPR2PSTA120AC	9713104	75320			DPST-NO w/AUX		120AC	PRD60442	PR32741		
OPR2PSTB120AC	9741008, 9715423	71924			DPST-NO	YES	120AC	PRD60440 PR3973	PR3723,	PRD7AH0120	199ABX-9
OPR2PST240AC	9713219, 9713268	71923, 72102	19240	H3088H02, H3088H016	DPST-NO		240AC	PRD60439, PRD11400, PRD60441	PR2710, PR2679, PR2820	PRD7AY0240	W199AX-10
OPR2PSTB240AC				H3088H01	DPST-NO	YES	240AC		PR1881	PRD7AH0240	
OPR2PST12DC			504742-12	H3088H020	DPST-NO		12DC			PRD7DY012	
OPR2PSTBDC	9909151, 9836676, 9776345	126673, 112634			DPST-NO	YES	12DC	PRD60581, PRD60162-1		PRD7DH012	199BX-7
OPR2PST24DC	9768257	76825	504742-024		DPST-NO		24DC	PRD60402	PR7DY024	PRD7DY024	W199X-8
OPR2PSTB24DC	9847054	147054			DPST-NO	YES	24DC	PRD60854	PR7DM, PRD60854	PRD7DH024	
OPR2PST48DC	9772698, 9769020, 9772686	77269, 77268, 76902	504742-048		DPST-NO		48DC	PRD60397	PR80075, PR80076	PRD7DY048	199X-17
OPR2PSTB48DC	9769018	76901	504640-048		DPST-NO	YES	48DC	PRD60396	PR7DM, PR80033	PRD7DH048	199BX-17
OPR2PST110DC				H3088H05, H3088H018, H3088H019	DPST-NO		110DC	PRD60520		PRD7DY0110	199X-9
OPR2PSTB110DC	9740145, 9741185	72104, 72768		H3088H015	DPST-NO	YES	110DC		PR3975	PRD7DH0110	199BX-9
OPR2PDT6AC					DPDT		6AC			PRD11AY06	
OPR2PDT12AC					DPDT		12AC			PRD11AY012	
OPR2PDTB12AC					DPDT	YES	12AC			PRD11AY012	
OPR2PDT24AC			28383, 502868-024		DPDT		24AC		PR2900	PRD11AY024	W199AX-13
OPR2PDTB24AC					DPDT	YES	24AC			PRD11AH024	
OPR2PDT120AC	9713207, 9741082	71922	19238, 55045, 511541, 502868-120	H3088H017	DPDT		120AC	PRD60438	PR2709, PR2678, PR2735	PRD11AY0120	W199AX-14
OPR2PDTA120AC	9755240	75524			DPDT w/AUX		120AC	PRD60444	PR11AL5		
OPR2PDTB120AC			55646, 514198-120		DPDT	YES	120AC			PRD11AH0120	W199ABX-14
OPR2PDT240AC	9713219	22419, 502868-240		H3088H011, H3088H014	DPDT		240AC			PRD11AY0240	
OPR2PDTB240AC				H3088H012	DPDT	YES	240AC			PRD11AH0240	
OPR2PDT12DC					DPDT		12DC			PRD11DY012	
OPR2PDTB12DC	9776357, 9742918	112635, 147053	504646-012		DPDT	YES	12DC	PRD604351, PRD608531		PRD11DH012	199BX-12
OPR2PDT24DC	9705533, 9768269	100555, 76826	502823-024		DPDT		24DC	PRD60403, PRD60401	PR11DY	PRD11DY024	W199X-13
OPR2PDTB24DC	9742920	142920			DPDT	YES	24DC	PRD60807		PRD11DH024	199BX-8
OPR2PDT48DC	9768993	76899	502823-048		DPDT		48DC	PRD60394	PR80032, PR3845	PRD11DY048	199X-18
OPR2PDTB48DC	9769043	76900	511099-048		DPDT	YES	48DC	PRD60395, PRD60394	PR3946	PRD11DH048	199BX-18
OPR2PDT110DC	9713360, 9741124, 9741150	72015, 72765, 72762		H3088H06	DPDT		110DC	PRD60398	PR2959, PR2782, PR27863	PRD11DY0110	W199X-14
OPR2PDTB110DC	9720121, 9809144	109149			DPDT	YES	110DC	PRD60816, PRD60521		PRD11DH0110	W199BX-14
OPR2PDT230DC					DPDT		230DC			PRD11DY0230	
OPR2PDTB230DC					DPDT	YES	230DC			PRD11DH0230	
OPR1PSTB24DC					SPST	YES	24DC				199DBX-3
OPR4PDT24AC			500943-024		4PDT		24AC			PM17AY24	
OPR4PDT120AC			500943-120		4PDT		120AC			PM17AY120	
OPR4PDT208AC			500943-208		4PDT		208AC			PM17AY208	
OPR4PDT240AC	9713050		500943-240		4PDT		240AC			PM17AY240	
OPR4PDT110DC					4PDT		110DC			PM17DY110	

CONTRACTORS, STARTERS, RELAYS & TIMERS

Questions? Answers at...
 (866) CED-ELEV • (866) 233-3538
 www.cedlevator.com

General Purpose Relays

Ice Cube Series

Contact Config	Coil Voltage	Features	OMRON	IDEC	Relpol	Schneider Electric
2PDT	120AC	LED	MY2N-AC-110/120(S)			
2PDT	6DC	LED	MY2N-DC6(S)			
2PDT	12DC		MY2-DC12(S)			
2PDT	12DC	LED	MY2N-DC12(S)			
2PDT	24DC	LED	MY2N-DC24			
2PDT	24DC	Latching	MY2K-US-DC24			
2PDT	48DC	Latching	MY2K-US-DC48			
2PDT	110DC	Latching		RY2KS-U-DC110V		
2PDT	120VAC	Latching	MY2KUSAC120			
4PDT	24DC			RY4S-UDC24V		
4PDT	24AC	LED		RY4S-ULAC24V		
4PDT	120AC	LED		RY4S-UL-AC110/120V		RXM4AB3F7
4PDT	240AC	LED		RY4S-ULAC240V		RXM4AB3P7
4PDT	24DC	LED		RY4S-UL-DC24V		RXM4AB3BD
4PDT	48DC	LED		RY4S-UL-DC48V		
4PDT	110DC	LED	MY4N-DC100/110(S)	RY4S-UL-DC100/110V		RXM4AB3FD
4PDT	24AC	LED & Test Button			R4N-2014-23-5024WTL	
4PDT	120AC	LED & Test Button	MY4IN-AC110/120(S)	RY4S-ULCAC110-120V	R4N-2014-23-5120WTL	
4PDT	240AC	LED & Test Button			R4N-2014-23-5240WTL	
4PDT	24DC	LED & Test Button	MY4IN-DC24(S)	RY4S-ULCDC24V	R4N-2014-23-1024WTL	
4PDT	48DC	LED & Test Button			R4N-2014-23-1048WTL	
4PDT	110DC	LED & Test Button	MY4IN-DC100/110(S)	RY4S-ULCDC100-110V	R4N-2014-23-1110WTL	
4PDT	12AC	LED & Bifurcated Contacts	MY4ZN-AC12(S)			
4PDT	120AC	LED & Bifurcated Contacts	MY4ZN-AC110/120(S)	RU42S-C-A110		RXM4GB3F7
4PDT	240AC	LED & Bifurcated Contacts	MY4ZN-AC220/240(S)			
4PDT	12DC	LED & Bifurcated Contacts	MY4ZN-DC12(S)			
4PDT	24DC	LED & Bifurcated Contacts	MY4ZN-DC24(S)	RU42S-C-D24		
4PDT	24DC	LED, Bifurcated Contacts & Surge Suppressor Diode	MY4ZN-D2-DC24(S)			
4PDT	48DC	LED & Bifurcated Contacts	MY4ZN-DC48(S)			
4PDT	110DC	LED & Bifurcated Contacts		RU42S-C-D110		RXM4GB3FD
4PDT	110DC	LED, Bifurcated Contacts & Surge Suppressor Diode	MY4N-D2-DC100/110(S)			
4PDT	120AC	LED & Test Button Bifurcated Contacts	MY4ZIN-AC110/120(S)			
4PDT	48DC	LED & Test Button Bifurcated Contacts	MY4ZIN-DC48(S)			
BASE			PYF14-AE	SY4S-05		70-461-1

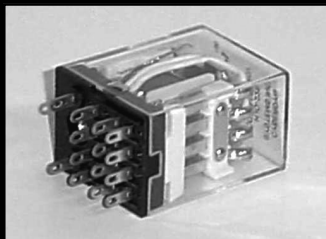

Manufacturer Cross Reference

Manufacturer	Series
Allen-Bradley	700-HC24
Aromat	HC4
Cutler-Hammer	MC4S
Iddec*	RY4S RY42S
Line Electric	SRE
Midtex	156
Omron*	MY4
P&B	KHAU
Square D	8501-RS14(AC) 8501-RSD14(DC)
Struthers-Dunn	C281XDX
Cyberdyn	HJQ22F
Schneider*	RXM

* Stock brands

Questions? Answers at...
 (866) CED-ELEV • (866) 233-3538
www.cedlevator.com

General Purpose Relays

Miniature Series

Contact Config	Coil Voltage	Features	OMRON	IDEC	Schneider Electric
1PDT	12DC	LED & Push Button			
1PDT	24DC	LED		RH1B-ULDC24V	
1PDT	24DC	LED & Push Button			RPM12BD
1PDT	24AC	LED & Push Button			RPM12B7
1PDT	120AC	LED		RH1B-ULAC120V	
1PDT	120AC	LED & Push Button			RPM12F7
1PDT	240AC	LED & Push Button			RPM12P7
1PDT BASE				SH1B-05	
1PDT BASE		Finger Safe Terminals			RPZF1
2PDT	12DC	Suppressor Diode	LY2D-DC12		
2PDT	24DC	Narrow base		RY2S-UDC24V	
2PDT	24DC			RH2B-UDC24V	
2PDT	24DC	LED		RH2B-ULDC24V	RPM23BD
2PDT	24DC	LED & Test Button			RPM22BD
2PDT	12DC	Suppressor Diode	LY2D-DC12		
2PDT	24DC	Suppressor Diode	LY2D-DC24		
2PDT	48DC	LED			RPM23ED
2PDT	110DC	LED		RH2B-UL-DC100/110V	
2PDT	110DC	LED & Test Button			RPM22FD
2PDT	110DC	Suppressor Diode	LY2D-DC100/110		
2PDT	24AC	LED			RPM23B7
2PDT	24AC	LED & Test Button			RPM22B7
2PDT	120AC	Narrow base		RY2S-UAC120V	
2PDT	120AC			RH2B-UAC110-120V	
2PDT	120AC	LED & Test Button			RPM22F7
2PDT	240AC	LED & Test Button			RPM22P7
2PDT	24DC	LED		RH2B-ULDC24V	RPM23BD
2PDT	48DC	LED		RH2B-ULDC48V	RPM23ED
2PDT	110DC	LED		RH2B-ULDC100-110V	RPM23FD
2PDT	24AC	LED		RH2B-ULAC24V	RPM23B7
2PDT	120AC	LED		RH2B-ULAC110-120V	RPM23F7
2PDT	240AC	LED		RH2B-ULAC220-240V	RPM23P7
2PDT BASE				SH2B-05	70-459-1
2PDT BASE		Finger Safe Terminals			RPZF2
3PDT	24DC		LY3-DC24		
3PDT	24DC	LED	LY3N-DC24		
3PDT BASE		Finger Safe Terminals			RPZF3
4PDT	24DC	LED		RH4B-ULDC24V	
4PDT	110DC	LED		RH4B-ULDC110V	
4PDT	110DC	LED & Test Button			RPM41FD
4PDT	120AC		LY4-AC120		RPM42F7
4PDT	120AC	LED	LY4N-AC110/120		RPM43F7
4PDT BASE		Finger Safe Terminals			RPZF4

Manufacturer	Series
Allen-Bradley	700-HF32
Aromat	HL2
Cutler-Hammer	MP2B
Idec	RH2B
Line Electric	SRT
Midtex	258
Omron*	LY2
P&B*	K10
Square D	8501-RS42
Struthers-Dunn	C281XBX
Schneider*	RPM

* Stock brands

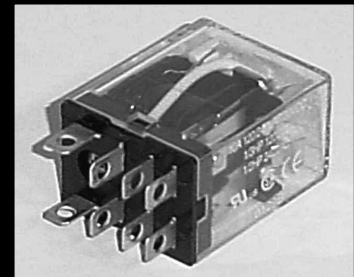

Questions? Answers at...
 (866) CED-ELEV • (866) 233-3538
 www.cedelelevator.com

General Purpose Relays

Blade Based Relays

Contact Config	Coil Voltage	Features	P&B	IDEC	Schneider Electric
2PDT	24DC	Flange Mount case, 20A	KUHP-11D51-24		
2PDT	24DC			RR2BA-UDC24V	
2PDT	48DC	LED			RUMF23ED
2PDT	110DC	LED			RUMF23FD
2PDT	120AC			RR2B-UAC120V	
2PDT	240AC			RR2B-UAC240V	
3PDT	24DC	LED	KUP-14D35-24	RR3B-ULDC24V	RUMF33BD
3PDT	24DC	LED & Test Button		RR3B-ULC-DC24V	
3PDT	48DC		KUP-14D15-48		
3PDT	48DC	LED			RUMF33ED
3PDT	110DC	LED	KUP-14D35-110	RR3B-ULDC110V	RUMF33FD
3PDT	110DC	LED & Test Button	KUP-14D45-110	RR3B-ULC-DC110V	
3PDT	24AC	LED			RUMF33B7
3PDT	120AC		KUP-14A15-120		
3PDT	120AC	LED	KUP-14A35F-120	RR3B-ULAC120V	RUMF33F7
3PDT	120AC	LED & Test Button	KUP-14A45-120	RR3B-ULC-AC120V	
3PDT	240AC	LED		RR3B-ULAC240V	RUMF33P7
3PDT	240AC	LED & Test Button			RUMF32P7
BASE				SR3B-05	70-463-1

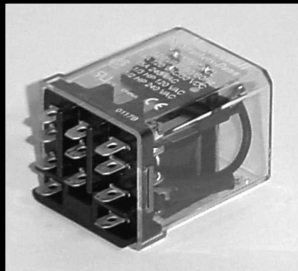

Manufacturer Cross Reference

Manufacturer Series	DPDT	3PDT
Allen-Bradley	700-HB32	700-HB33
Aromat	HP32	HP33
Cutler-Hammer	D5PR2	D5PR3
Idec	RR2B	RR3B
Line Electric	CRH102C	CRH103C
Midtex	157-22	157-23
P&B*	KUP11	KUP14
Square D	8501-KU12	8501-KU13
Struthers-Dunn	A283XBX	A283XCX
Schneider*	RUMF2	RUMF2

* Stock brands

Questions? Answers at...
 (866) CED-ELEV • (866) 233-3538
www.cedlevator.com

General Purpose Relays

Octal Base Series

Contact Config	Coil Voltage	Basic Relay	With LED & Push Button
DPDT	6AC	GPO2PDT6AC	GPO2PDTLPB6AC
DPDT	12AC	GPO2PDT12AC	GPO2PDTLPB12AC
DPDT	24AC	GPO2PDT24AC	GPO2PDTLPB24AC
DPDT	120AC	GPO2PDT120AC	GPO2PDTLPB120AC
DPDT	240AC	GPO2PDT240AC	GPO2PDTLPB240AC
DPDT	6DC	GPO2PDT6DC	GPO2PDTLPB6DC
DPDT	12DC	GPO2PDT12DC	GPO2PDTLPB12DC
DPDT	24DC	GPO2PDT24DC	GPO2PDTLPB24DC
DPDT	48DC	GPO2PDT48DC	GPO2PDTLPB48DC
DPDT	110DC	GPO2PDT110DC	GPO2PDTLPB110DC
3PDT	6AC	GPO3PDT6AC	GPO3PDTLPB6AC
3PDT	12AC	GPO3PDT12AC	GPO3PDTLPB12AC
3PDT	24AC	GPO3PDT24AC	GPO3PDTLPB24AC
3PDT	120AC	GPO3PDT120AC	GPO3PDTLPB120AC
3PDT	240AC	GPO3PDT240AC	GPO3PDTLPB240AC
3PDT	6DC	GPO3PDT6DC	GPO3PDTLPB6DC
3PDT	12DC	GPO3PDT12DC	GPO3PDTLPB12DC
3PDT	24DC	GPO3PDT24DC	GPO3PDTLPB24DC
3PDT	48DC	GPO3PDT48DC	GPO3PDTLPB48DC
3PDT	110DC	GPO3PDT110DC	GPO3PDTLPB110DC

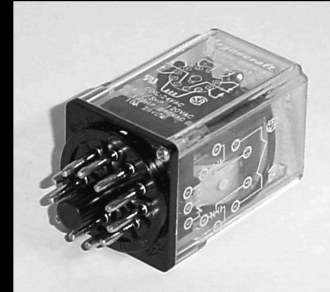

OEM Cross Reference

Part Number	Armor Number	Montgomery Number	Otis Number
GPO1PDT24AC	11350-01		VP-840005
GPO2PDT24DC	11341-01		
GPO1PDT24DC	11344-01		
GPO2PDT6AC	11345-01		
	11347-01		
	12526-01		
GPO2PDT110DC	12574-01		
GPO2PDT240AC	12520-01		
GPO3PDT240AC		502835-240	

Manufacturer Series	DPDT	3PDT
Allen-Bradley	700-HA32	700-HA33
Cutler-Hammer	MR2P	MR3P
Idec	RR2P	RR3PA
Line Electric	MKH2C	MKH3C
Midtex	158-92	
Omron	MK2P	MK3P
P&B	KRPA11	KRPA14
Square D	8501-KP12	8501-KP13
Struthers-Dunn	A314XBX	A314XCX
Schneider*	RUMC2	RUMC3
Finder*	60.12	60.13

* Stock brands

Questions? Answers at...
 (866) CED-ELEV • (866) 233-3538
www.cedelevator.com

Relay Bases

P&B Number	Midtex Number	Omron Number	MSD Number	Idec Number	Custom Connector	Aromat Number	Figure Number
27E305					CM11-LPCB		1
27E1038			70-478-1	RP-78-604	ES35		
27E1039			70-475-1	RP-78-605	ES50		
27E304	670-0013		70-178-1		CM11-PCB		1
27E488	S258-2SL00	PT08	70-401-1	SH2B-51	GR108-SLD		6
27E006	670-0002	PY14	70-378-1	SY4S-51	MR14-SLD		8
27E031	670-0003	PY14	70-379-1	SY4S-61	MR14-PCB		8
27E067	670-0012		70-124-2		CM11-QDC		1
27E043	670-0009		70-124-1	SR3B-51	CM11-SLD		1
27E489	S258-2PC00	PT08-0	70-402-1	SH2B-62	GR108-PCB		6
20C217		PYC-P	16-1197		HDB-4		10
27E023	670-0033	PY08-02	70-402-1		MR08-PCB-1G	HC2-PS-K	8
27E007	670-0014	PY14-02	70-379-1		MR14-PCB-1G	HC4-PS-K	8
27E895	D258-2TS00	PTF08A-E	70-459-1	SH2B-05	GT08-PC		7
27E894	670-0120	PYF14AE	70-461-1	SY4S-05	MT14-PC		9
27E122*	670-0127	PF083A-E	70-464-1	SR2P-06	OT08-PC		4
27E121	670-0125		70-463-1	2R3B-05	SS11-PC		3
		PF083A-E	70-464-1	2R3B-05	OT08-PC		4
27E123	670-0126	PF113A-E	70-465-1	SR3P-06	OT11-PC		5
27E895	D258-2TS00	PYC-A1	16-1197		GT08-PC		7
27E166	670-0120				MT14-PC		9
27E487	S258-2TS00				GR108-PC		6
27E893	D157-3TS00		70-463-1	SR3B-05	ST11-PC		2

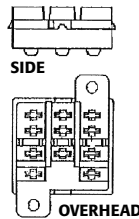

FIGURE 1
Chassis Mount
Square Base

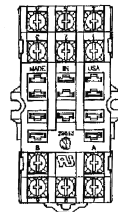

FIGURE 2
Direct or DIN
Rail Mount
Square Base

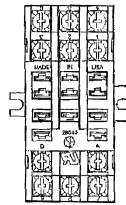

FIGURE 3
Direct Mount
Square Base

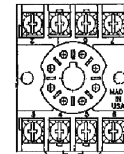

FIGURE 4
8-Pin Direct or DIN
Rail Mount
Octal Base

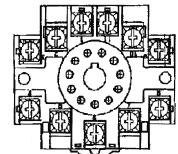

FIGURE 5
11-Pin Direct or DIN
Rail Mount
Octal Base

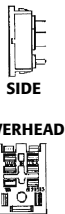

FIGURE 6
Chassis Mount
DPDT
Miniature Base

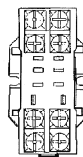

FIGURE 7
Direct or DIN
Rail Mount DPDT
Miniature Base

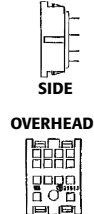

FIGURE 8
Chassis Mount
4PDT
Ice Cube Base



FIGURE 9
Direct or DIN
Rail Mount 4PDT
Ice Cube Base

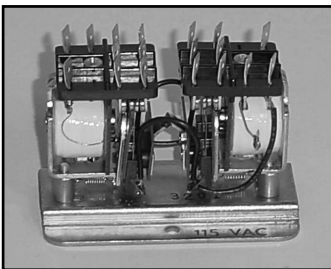

FIGURE 10
Hold Down
Spring Clip

Questions? Answers at...
(866) CED-ELEV • (866) 233-3538
www.cedlevator.com

Miscellaneous & Special Purpose Relays

Manufacturer	Part Number	Description
Line Electric	RL6880	Latching, DPDT Dual 240VAC Coil, Enclosed, Dover 9860095
Line Electric	RL6947	Latching, Dual Coil 115VDC, Open, Dover 9753047, P&B KB1228
Line Electric	1223A120VAC	3PDT, Replaces Guardian 1220-3C-12, A410-361341-01 3PDT, A410-361341-00, A410-361344-00, A410-365633-15
Line Electric	RL5538	Latching, Dual 120VAC Coil, Enclosed
S-D	A275KXX91-120VAC	Reversing Contactor, 120VAC Coils
S-D	A575KXX90-48VDC	Reversing Contactor, 48VDC Coils
Omron	G7J4ATW1AC100120	4N.O. 120 VAAC (Replaces Obsolete Aromat VC15-4A-AC120V)
Omron	G7J3A1BTW1AC100120	3N.O. 1N.C. 120VAC (Replaces Obsolete Aromat VC15-3A1B-AC120V)
Omron	G7J2A2BTW1AC100120	2N.O. 2N.C. 120V w/ P.B. (Replaces Obsolete Aromat VC15-2A2B-AC120V-H8)
Omron	G7J3A1BBW1AC100120	3N.O. 1N.C. 120VAC, Screw Terminals (Replaces obsolete Aromat (VC15S-3A1B-AC120V)
Line Electric	AHTR3A120	3PDT, 120VAC Coil, 1.85k Ohm
Line Electric	AHTR3D110	3PDT, 110VDC Coil, 10k Ohm
Omron	LY2D-DC12	DPDT with Diode Surge Suppression on Coil, Dover 9783295
Omron	LY2D-DC24	DPDT with Diode Surge Suppression on Coil, Dover 9783398
Omron	MY4N-D2-DC100/110(S)	4PDT with Diode Surge Suppression on Coil, Dover 9811060
Omron	MY4N-D2-DC24(S)	4PDT with Diode Surge Suppression on Coil, Dover 9791061
Omron	LY4-AC110/120	4PDT 120AC Coil, 10 AMP
Omron	LY4N-AC110/120	4PDT 120AC Coil w/LED, 10 AMP



OPEN STYLE, DUAL COIL LATCHING

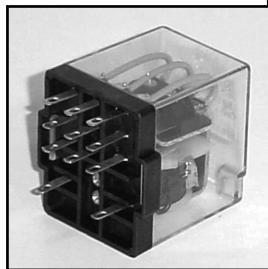

1223A120VAC



VC15 RELAY



4PDT 10AMP RELAY

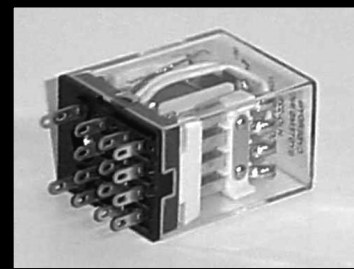
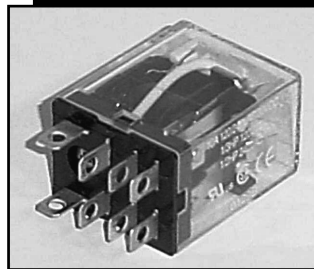
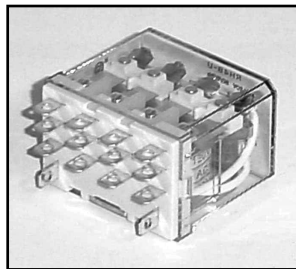
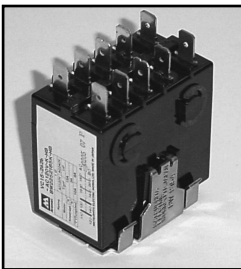

Questions? Answers at...
(866) CED-ELEV • (866) 233-3538
www.cedelevator.com

Phase Monitors - Under Voltage, Over Voltage, Phase Reversal, Loss of Phase

Item	Type	Key Feature	Manufacturer	Part Number	Voltage Range	Contacts
A	plug in, socket mounted	single voltage range	Time Mark	258B	160V - 240V	SPDT
B	plug in, socket mounted	single voltage range	Time Mark	A258B	380V-480V	SPDT
C	plug in, socket mounted	single voltage range	Time Mark	B258B	85V - 120V	SPDT
D	plug in, socket mounted	universal voltage range	Diversifield Electronics	SLU-0201	200V - 500V	SPDT
E	DIN rail mount *	highest level of protection	SSAC	DLMUBRAAA	200V - 480V	SPDT & NO
E	DIN rail mount *	highest level of protection	SSAC	DLMHBRAAA	500V - 600V	SPDT & NO
F	DIN rail mount	narrow package (22.5mm)	Omron	K8AKPM1200240VAC	200V - 240V	2X SPDT
F	DIN rail mount	narrow package (22.5mm)	Omron	K8AKPM2380480VAC	380V - 480V	2X SPDT

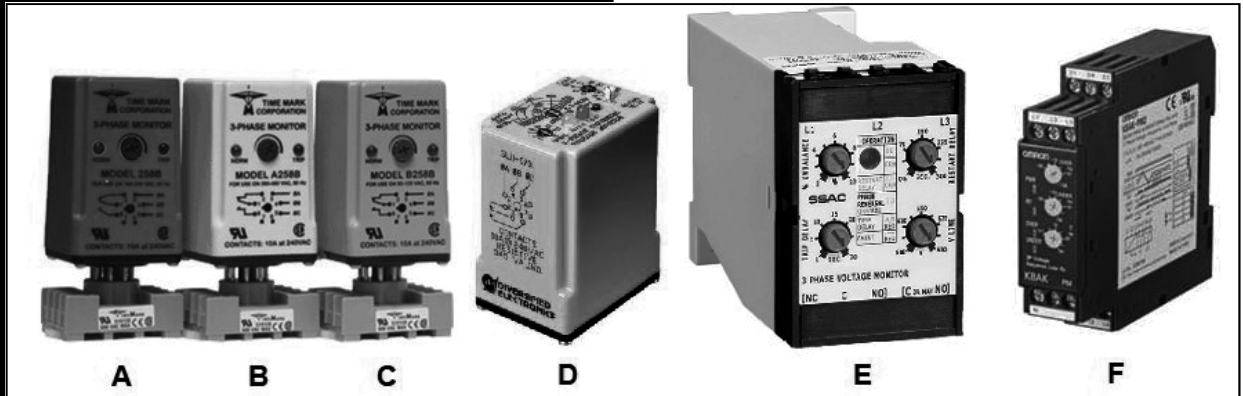

Questions? Answers at...

(866) CED-ELEV • (866) 233-3538
www.cedlevator.com

Timing Relays

Form	Type	Manufacturer	Part #	Voltage range	Function	Timing Range	Controls	Contacts
A	Plug in, 14 pin ice cube	Omron	H3YN2-AC100120	100-120vac	On delay, Interval, Flicker OFF start, Flicker ON	0.1s ~ 10min	knob control & recessed screw pots	DPDT (5 amp)
B	Plug in, 8-pin octal	Diversified Elect	TDT-24-AKA-010	24v ac/dc	True Off delay	0.1s ~ 10s	knob control	DPDT (10 amp)
B	Plug in, 8-pin octal	Diversified Elect	TDT-24-AKA-030	24v ac/dc	True Off delay	0.3s ~ 30s	knob control	DPDT (10 amp)
C	Plug in, 8-pin octal	RK Elect	CCB-115A-2-10S	115vac	On delay	0.1s ~ 10s	knob control	DPDT (10 amp)
C	Plug in, 8-pin octal	RK Elect	CCB-24A-2-10S	24vac	On delay	0.1s ~ 10s	knob control	DPDT (10 amp)
D	Plug in, 8-pin octal	Finder	88.12.0.230.0002	24-230v ac/dc	On delay, On Pulse, w/out signal, Pulse on.. on/off & off operation	0.05s ~ 100hrs	knob control & recessed screw pots	DPDT (8 amp)
E	Plug in, 8-pin octal	SSAC	TRU1	19-264vac 19-30vdc	On delay, Interval & recycling	0.1s ~ 1000s	Knobs, DIP switch & slide switch	DPDT (10 amp)
E	Plug in, 11-pin octal	SSAC	TRU3	19-264vac 19-30vdc	On delay, Off delay, Interval, single shot & recycling	0.1s ~ 1000s	Knobs, DIP switch & slide switch	DPDT (10 amp)
D	Plug in, 11-pin octal	Finder	88.02.0.230.0002	24-230v ac/dc	On delay, Off delay, On Pulse, Fixed Pulse (0.5s), recycle on w/out signal, Pulse on..on/off & off	0.05s ~ 100hrs	knob control & recessed screw pots	DPDT (8 amp)
F	Plug in, 11-pin octal	Omron	H3CA-A	24 - 240vac 12 - 240vdc	On delay, Interval, Signal OFF delay (2 versions), Signal ON/OFF delay (2 versions), Repeat cycle	0.1s ~ 9,999.0hrs	Digital push buttons w/LCD display	SPDT (3 amp)
G	Plug in, 11-Blade	Schneider Electric	TDR-SOXB-120	120v ac/dc	On delay, Interval	0.1s ~ 10hrs	knob control & DIP switches	DPDT (12 amp)
H	DIN rail mounted	ABB	1SVR730010R0200	24-240v ac/dc	On delay, Off delay, Star-Delta, Impulse (on & off), Flasher (on & off)	0.05s ~ 300hrs	recessed screw pots	2x SPDT (4 amp)
H	DIN rail mounted	ABB	1SVR730010R3200	24-240vac 24-48vdc	On delay, Off delay, Star-Delta, Impulse (on & off), Flasher (on & off)	0.05s ~ 300hrs	recessed screw pots	2x SPDT (4 amp)
I	DIN rail mounted	ABB	1SVR730100R3100	24-48vdc 24-240vac	On delay	0.05s ~ 300hrs	recessed screw	SPDT (4 amp)
J	Panel mount, cube type	SSAC	TDU3000A	24-120v ac/dc	On delay	1s ~ 1023s	DIP switches	1NO (1 amp)
J	Panel mount, cube type	SSAC	TDUL3000A	24-120v ac/dc	On delay	1s ~ 102.3s	DIP switches	1NO (1 amp)
K	Panel mount, cube type	Artisan	438USA	19-288v ac/dc	On delay	1s ~ 1024s	DIP switches	1NO (1 amp)
L	Panel mount, cube type	ICM (Omnetics)	MMS110DIZ10A	110vdc	On delay	10s	resistor or external 1NO potentiometer	20mA - 1 amp
L	Panel mount, cube type	ICM (Omnetics)	MMS110D5Z1A	110vdc	On delay	1s	resistor or external 1NO potentiometer	20mA - 1 amp
L	Panel mount, cube type	ICM (Omnetics)	MMS115A5Y1A	115vac	On delay	1s	resistor or external 1NO potentiometer	20mA - 1 amp
L	Panel mount, cube type	ICM (Omnetics)	MMS115A5Z120A	115vac	On delay	120s	resistor or external 1NO potentiometer	20mA - 1 amp
M	Panel mount, cube type	ICM (Omnetics)	MMS115AZ480B	115vac	On delay	480s	resistor or external 1NO potentiometer	20mA - 1 amp
N	Panel mount DIN rail mount	Omron	H5L-A	100-240vac	Programable 24hr x 7days 24 on/off operations	weekly timer 00:00 ~ 23:59 divisible by 1 min	push button	2x SPST-NO

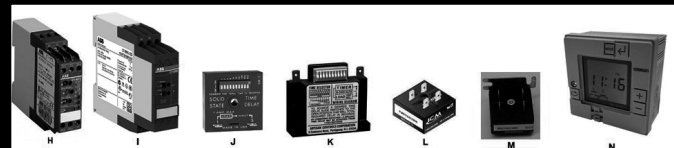

Questions? Answers at...
 (866) CED-ELEV • (866) 233-3538
 www.cedelevator.com

DOOR OPERATORS
& PARTS

GAL REPLACEMENT
PARTS & COMPONENTS

In this Section

GAL MOVFR Closed Loop Operators . . . 4.2
 GAL MOVFE Linear Operators 4.2
 GAL Replacement Parts 4.3-4.7
 Replacement Rollers 4.8-4.12
 MAC/Columbia Door Operators . . 4.13-4.14
 MAC/Columbia Replacement Parts . . . 4.15
 Door Gibs and Fire Tabs 4.16
 Spirators and Door Bumpers 4.17
 ECI Door Boards 4.18
 Door Straps 4.19

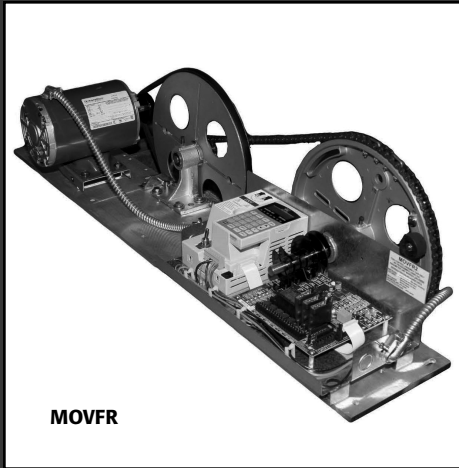

MOVFR



MOVFE LINEAR DOOR OPERATOR

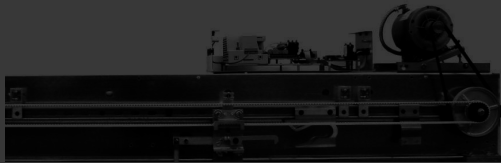

RIGHT HAND HEAVY DUTY



LEFT HAND HEAVY DUTY



CENTER PARTING HEAVY DUTY

Door Operators

GAL MOVFR - Closed Loop Operators

- Extremely quiet operation
- The most dependable door operator ever from GAL
- Door Control with built-in Diagnostics
- Closed Loop regulated speed via motor performance feedback.
- Keypad programming
- Plug & Play Door protection

Part Number	Description
OP99-000SR	42" SS Right Handed Door Operator
OP99-0005L	42" SS Left Handed Door Operator

GAL MOVFE Linear Door Operators

- Extremely quiet operation
- Double feedback, closed loop system
- Quick and easy to install
- Completed door operators installed on headers in the following sizes: 36" and 42" LH/RH Side Slide, 42" Center Parting
- Hall side door hangars and interlock assemblies in stock for matching door operator sizes
- Call CED for any other door opening size or setup

LINEAR DOOR OPERATORS AVAILABLE IN STOCK

Part Number	Description
2500-6050 2L	36" SSL LH MOVFE DOOR OPERATOR
2500-6050 2R	36" SSL RH MOVFE DOOR OPERATOR
2500-5050	36" CP MOVFE DOOR OPERATOR
2500-6100 2L	42" SSL LH MOVFE DOOR OPERATOR
2500-6100 2R	42" SSL RH MOVFE DOOR OPERATOR
2500-5100-2L	42" CP MOVFE DOOR OPERATOR

LINEAR DOOR OPERATOR PARTS

Part Number	Description
2500-3051	HAND HELD PARAMETER UNIT
896-3028	PICK UP ROLLER MOUNTING PLATE
SW1-0048N	GATE SWITCH
892-3019	CLUTCH MOUNTING PLATE

G.A.L. Door Operator Interlocks

Contact Assemblies

Part Number	Description
INT1H-0024R	Contact assembly for MO interlock, RH, complete; includes canvas/phenolic insulator
INT1H-0024L	Contact assembly for MO/MOCP interlock, LH, complete; includes insulator; use with RH contact assembly
INT2H-0018R	Contact assembly for MOCP interlock, RH, complete; includes canvas/phenolic insulator
INT1H-0036R	MO contact kit, RH; includes one each: contact assembly, MO keeper bridging block, canvas/phenolic insulator and mounting screws
INT1H-0036L	MO/MOCP contact kit, LH; includes one each: contact assembly, MO keeper bridging block, canvas/phenolic insulator & mounting screws; use with RH contact kit
INT2H-0017R	MOCP contact kit, RH; includes one each: contact assembly, MO keeper bridging block, canvas/phenolic insulator and mounting screws

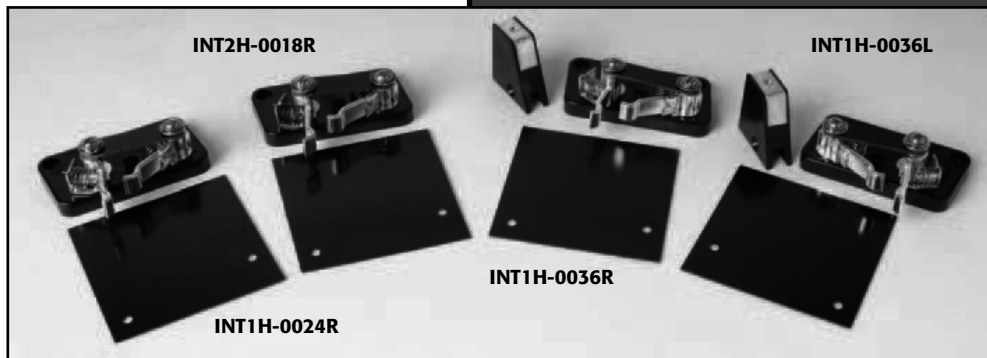

Interlock Kits

Part Number	Description
INT1H-0002L	MOH interlock kit, LH; includes one each: witch housing, keeper assembly, lower linkage, and horizontal release assembly.
INT1H-0002R	MOH interlock kit, RH; includes one each: switch housing, keeper assembly, lower linkage, upper linkage, and MOH horizontal release assembly.



Questions? Answers at...
 (866) CED-ELEV • (866) 233-3538
www.cedelevator.com

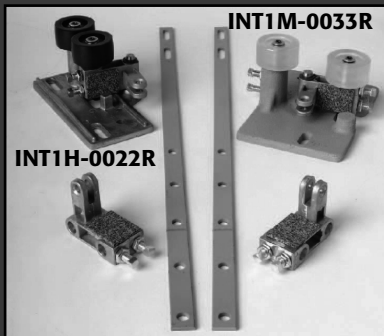
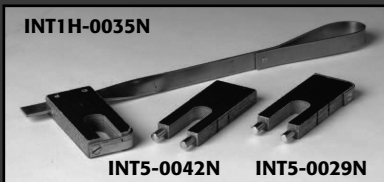
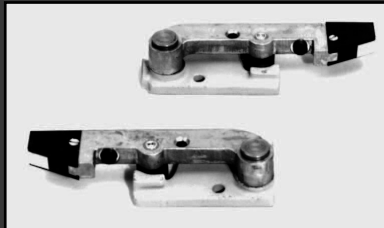

G.A.L. Door Operator Interlocks & Jumpers

MO Keeper

Part Number	Description
INT1H-0016R	MO keeper assembly, RH; includes cast iron mounting base, brass keeper, keeper bridging block contact
INT1H-0016L	MO keeper assembly, LH; same as above
INT1H-0017N	MO keeper bridging block contact MO adjustable linkage kit;
INT1H-0026N	MO lower linkage; includes snap link pin & lower bushing
INT1H-0018N	MO upper linkage; includes snap link pin & retainer clip

GAL Jumpers

Part Number	Description
INT1H-0035N	"Tomahawk" with MO jumper head & 10½" long looped handle
INT5-0029N	Double-barrel contact head
INT5-0042N	Combination MO jumper head does the job of both jumpers above; no handle.

MOH Horizontal Release & MOM Vertical Release

Part Number	Description
INT1H-0022R	MOH horizontal release assembly, complete; RH; includes aluminum mounting base, release rocker, clutch rollers, lower actuator link snap link bushing.
INT1H-0022L	MOH horizontal release assembly, complete; LH; MOM release rocker; includes set screws, nuts, bumper pad. Can be used for both right- and left-hand applications.
INT1M-0033R	MOM vertical release assembly, complete; RH; includes cast iron mounting base, release rocker, clutch rollers, lower actuator link, snap link bushing
INT1M-0033L	MOM vertical release assembly, complete; LH;

MO Interlock

Part Number	Description
INT1H-0013R	MO interlock switch housing and contacts, RH; complete with mounting plate
INT1H-0013L	MO interlock switch housing and contacts, LH; complete with mounting plate

G.A.L. Door Operator Interlock Components

DOOR OPERATORS & REPLACEMENT PARTS

Interlock Components

Part Number	Description
INT1H-0023N	Replacement clutch roller (flat) & shaft; brown heavy-duty poly roller, diameter = 1 1/2"
INT1H-0034N	Corridor door lock key, KMO-type (universal)
INT1H-0129N	Type M key for swing doors
RH LC-0021R	Movable contact finger for intermediate relay
LH LC-0021L	Movable contact finger for intermediate relay Stationary silver contact for intermediate relay; 3/8"-diameter silver contact on threaded hex stud w/nut; 1" length overall
CONT-0001L	Stationary carbon contact for intermediate relay; 3/8"-dia. carbon contact on threaded hex stud w/nut
KVP84D	Door Key Value Pack; includes one each: G840, G841, W824L, W824T, O825A, O825B, O825C



Keeper & Locking Components

Part Number	Description
CLU3-0328L	Locking Bar Guide, LH
INT6-0001R	Door Lock Assembly, SM, RH
INT6-0001L	Door Lock Assembly, SM, LH
INT22-0001L	Interlock, Type "N", LH
INT5-0025N	Interlock Roller, 4 1/2" centers
INT5-0027N	Roller & Bolt
SW1-004N	Gate Switch Assembly, Complete
SW1-0010N	Operating Cam Assembly
INT1H-0019N	Keeper Stem Bumper
CLU5-004N	Locking Bar
CLU3-0031L	Locking Cam, LH
CLU3-0031R	Locking Cam, RH

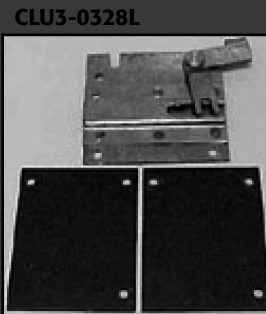

GAL Door Motor

Part Number	HP	Voltage	Description
MTR-0008N	1/6	230DC-PM	2 WIRES
MTR-0009N	1/4	230DC-PM	2 WIRES

OPERATOR MODEL: MOD, MODCT, MODCTA, MODCTL, MODCTLV, MODHFL, MODL, MODLNYC, RETIRING CAM (RC1)



Questions? Answers at...
(866) CED-ELEV • (866) 233-3538
www.cedelevator.com

Part Number	Description
CL5-0001R	CLOSER, SS 22-27 DO & CP 24-55 DO SPRING
CL5-0013R	CLOSER, S2 41-44 DO & 2 CP 83-90 DO SPRING
CL5-0051N	SPRING ROD
CL6-0001N	CLOSER, REEL ASSEMBLY
CLU1-0036N	ROLLER, 13/16" DIA LW CLUTCH
CLU1-0037N	ROLLER, 15/16" TYPE "L&L-LOW" CLUTCH
CLU1-0038N	CAM, CLUTH ACTUATING
CLU3-0260L	LKG.ASSY. LH.LWZ-1 CLUTCH
CLU3-0260R	LKG.ASSY. RH,LWZ-1 CLUTCH
CLU3-0267R	LKG.ASSY. LWZ-1 CLUTCH
CLU3-0331L	CAM,LWZ-1 STANDARD LKG.ASSY.
CLU3-0331R	CAM,LWZ-1 STANDARD LKG.ASSY.
CLU9-0001L	CLUTCH,LWZ-2 10"LINK W/24"ROD
CLU9-0001R	CLUTCH,LWZ-2 10"LINK W/24"ROD
CLU9-0002L	CLUTCH LWZ-2 6" LINK
CLU9-0003L	CLUTCH, LWZ-2, 8" LINK W/ 24" ROD
CLU9-0003R	CLUTCH, LWZ-2, 8" LINK W/ 24" ROD
CLU9-0004R	CLUTCH LWZ-2, 12" LINK
CLU9-0014R	CLUTCH, LWZ-2 LOW 6" LINK SS 30-34 / 2SP 27-34 /3SP 35-39 DO's
CLU9-0047L	CAM, LWZ-2 CALIFORNIA LOCKING (INCLUDES HARDWARE)
CLU9-0049L	CAM,LWZ-2 STANDARD LOCKING W/HDWE
CLU9-0049R	CAM,LWZ-2 STANDARD LOCKING W/HDWE
CLU9-0094N	ROD,24"LWZ-2 CLUTCH ZONE LKG
CLU9-0108N	ROD,36" LWZ-2 CLUTCH ZONE LOCKING
CLU9-0115L	LKG.ASSY.LWZ2 CLUTCH
CLU9-0115R	LKG.ASSY.Y LWZ-2CLUTCH W/CA CAM
DRV-0003N	PARAMETER UNIT FR-PU04-7 HAND HLD



Part Number	Description
DRV-0009N	PARAMETER UNIT, MOVFR HAND HELD 7
EMER-0001N	EMERGENCY LIGHT/EL4 UNIT WITH SOCKET LTS
EMER-0034N	EMERGENCY LIGHT/EL4 UNIT
EMER-0069N	EMERGENCY LIGHT UNIT, EL4 LED
HH1-0022L	USE HH1-0105L INSTEAD!!
HH1-0022R	USE HH1-0105R INSTEAD
HH1-0024N	ECCENTRIC, "A" SHEAVE
HH1-0025N	ROLLER KIT, 3 1/4" DIA "A"
HH1-0026N	OBSOLETE USE (HH1-0149N 30PK)
HH1-0027N	SHIM, 1/32" A" SHEAVE 3/8 BOLTS
HH1-0031N	SHIM, 1/8" A" SHEAVE 3/8 BOLTS
HH1-0032N	1/8" TRACK SPACER
HH1-0100N	36" HATCH TRACK SSL
HH1-0102N	HANGER, A-SS 40"-42" D.O. HATCH
HH1-0105L	SHEAVE, 4-1/8" CL W/TOP SFTY. RETAIN
HH1-0105R	SHEAVE, 4-1/8" CL W/TOP SFTY RETAIN
HH1-0112N	RETAINER, TYPE "A" HANGER TOP SAFETY
HH1-0149N	3-1/4 (TYPE A) OILER, 30 PACK
HH3-0051N	36" CP TRACK
HH3-0053N	42" CP TRACK
HH5-0029N	OILER (TYPE C) HNDR 3 1/4" ROLLER
HWBL-0001N	BELT, 2440 OPERATOR, "V" BELT 4L440
HWBR-0008N	BEARING KIT 7/8 SHOULDER
HWBR-0009N	BEARING KIT 7/8 WITH RETAINER
HWBS-0002N	BUSHING/NYLINER 5/8 ID TYPE 4
HWBS-0003N	BUSHING/NYLINER 7/16 IK
INT18-0015N	CONTACT, WP/WX INTERLOCK BRIDGING
INT1H-0003L	INTERLOCK MOH C LINK
INT1H-0003R	INTERLOCK MOH C LINK
INT1H-0013L	SWITCH ASSEMBLY, MO INTERLOCK



Questions? Answers at...

(866) CED-ELEV • (866) 233-3538
www.cedlevator.com

GAL Door Operator Replacement Parts

Part Number	Description
INT1H-0016L	KEEPER ASSEMBLY MO INTERLOCK
INT1H-0016R	KEEPER ASSEMBLY, MO INTERLOCK
INT1H-0019N	KEEPER STEM BUMPER
INT1H-0136L	REL.ASSY. Y MOH C LINK HORZ LEFT
INT1H-0136R	REL.ASSY.MOH C LINK RIGHT
INT22-0001L	INTERLOCK, TYPE "N", LH
INT22-0003L	INTERLOCK,"N" SWING 4 1/2"CL ARM
INT22-0011L	SWITCH ASSEMBLY "N" INTERLOCK
INT22-0011R	SWITCH ASSEMBLY "N" INTERLOCK
INT22-0015N	COVER "N" INTERLOCK
INT22-0019N	CONTACT KIT,N/NHA INTERLK UPPER
INT22-0020N	CONTACT KIT,"N"INTERLK LOWER
INT2H-0001N	INTERLOCK,MOCPH A LINK, C/P 24-39
INT2H-0002N	INTERLOCK MOCPH C/P 40"-49"
INT2H-0015N	KEEPER FIXED, MOCP INTERLOCK
INT2H-0052N	BRACKET, MOCP/MOH KEEPER MOUNTING
INT2H-0053N	CHANNEL, 2-3/16" MOCP/MOH LOCK MOUNTING
INT4-0001N	KEEPER, M/N INTRLK.SWING DOOR
INT5-0014N	CONTACT KIT, M INTERLOCK UPPER
INT5-0015N	CONTACT KIT, M INTERLOCK LOWER
KEY-0069N	KEY, GAL "1613' CODE
MTR-0008N	MOTOR,1/6 HP 230VDC PM (2WIRES)
MTR-009N	MOTOR,1/4 HP 230VDC
OP10-0006N	CONTACT SCREW, OPERATOR LIMIT
OP10-0032N	STOP, OPERATOR PULLEY
OP10-0058L	MICROSWITCH KIT, FM-MODL OPERATOR
OP10-0058R	MICROSWITCH KIT, FM-MODL OPERATOR
OP22-0741N	CRANK ARM ASSEMBLY 17-7/16
PB1-0021N	PUSH BUTTON, RWB "BLANK" 2NO-120V NEON
PB1-0025N	PUSH BUTTON, RWB "ARROW" 2NO-120V
PB2-0373N	BASE ASSEMBLY, VP 2NO PUSH BUTTON
PIN-0044N	PIN 5/8"X5/8" BLACK NYLON
PIN-0045N	PIN 1/8"X5/8" CLEAR NYLON
RES-0099N	RESISTOR, 300 OHM 100W
ROL-0006N	ROLLER, GATE SWITCH 1-1/4" OD
SPG-0046N	SPTING, 18-1/2 LG X 21/32 OD-0.105 WIRE
SW1-0003N	CONTACT KIT G-KT GATE SWITCH
SW1-0005N	ROLLER & ARM, GATE SWITCH
PRESS	DOOR ARM BEARING REMOVAL & INSTALLATION PRESS

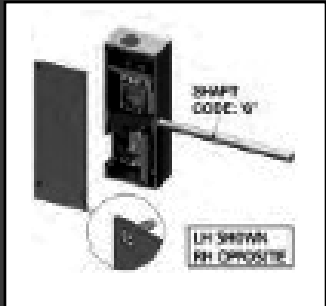

INT22-0011L/R

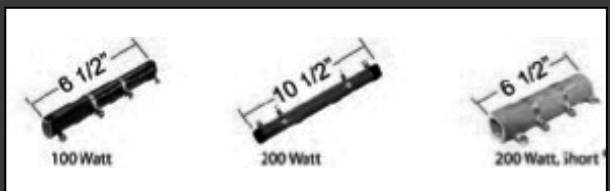

RES-0099N

Questions? Answers at...
(866) CED-ELEV • (866) 233-3538
www.cedelevator.com

Rollers Kone/Montgomery



ME971



P-13787

M411M



M410M



Part Number	Description	Poly Tire	Poly Color	OEM Part No.
M410M	Door hanger roller for MAC door operator; 3 ⁵ / ₈ "-O.D. polyurethane tire with ⁹ / ₃₂ " concave radius; includes ⁷ / ₁₆ -20 threaded axle stud with hex jam nut	LFx ⁷⁰	Red	P-31344 MAP-344
M411M	Door hanger roller for MAC door operator; 2 ⁷ / ₈ "-O.D. polyurethane tire with ⁹ / ₃₂ " concave radius; includes ⁷ / ₁₆ -20 threaded axle stud with hex jam nut	LFx ⁷⁰	Red	P-31341 MAP-341
ME971	Roller guide wheel for hydraulic elevators and escalators; precision-machined aluminum hub with 3 ¹⁵ / ₁₆ "-O.D. tire, ⁷ / ₈ "W; bearing I.D. = 0.7874"	HDx ⁹⁵	Clear	P-12963 P-12908
P-13787	Roller guide wheel 6.5" diam.			

Color Key for Adams Poly
 Red = LFx80 Low Friction
 Black = SPx80 Soft
 Clear = HDx95 Heavy Duty

Rollers Dover

POLY ROLLERS

Looking for the quietest guide roller?
Adams' SPx80™ "Quiet Poly" guide rollers
give the quiet ride you enjoy with rubber...
PLUS these major advantages:

- "Quiet" rollers last longer than rubber
- They stand up to petroleum products that invade hoistway, reduce life
- "Quiet" rollers resist ozone degradation

Look for the "S" in the Adams part numbers below. It stands for SPx80 Quiet Poly—the Durabond™-family polyurethane guide roller that's short on noise...and long on life!



COLOR KEY FOR ADAMS POLY

Red = LF^{x80} Low Friction
Black = SP^{x80} Soft
Clear = HD^{x95} Heavy Duty

Part Number	Dia.	Width	Description	Bearing Hub Type	Bore	Dover Part No.
D410M	3 5/16"	3/4"	Door hanger roller for high-pocket hanger assembly #9838533	Machined aluminum	0.6693"	9864295
D411M	27/8"	3/4"	Door hanger roller for low-pocket hanger assembly #9838540	Machined aluminum	0.6693"	9838302
D412	3 1/4"	3/4"	Door hanger roller for hanger roller assembly #66137	Machined aluminum	0.6693"	9861245
D413M	3 1/4"	3/4"	Door hanger roller, Dover-Turnbull; 0.525"W flat groove	Machined aluminum	0.6693"	23322G01
D414M	3"	3/4"	HDx95 guide roller for hydro's; double-sealed bearings	Machined aluminum	0.6693"	9834734
D420S	4"	1 1/4"	SPx80 Quiet Poly roller for #65150 roller guide assembly	Machined aluminum	0.6693"	9832774
D420	4"	1 1/4"	HDx95 heavy-duty roller for #65150 roller guide assembly	Machined aluminum	0.6693"	9832774
D421S	4"	3/4"	SPx80 Quiet Poly roller for #63314 roller guide assembly	Machined aluminum	0.6693"	9831873
D421	4"	3/4"	HDx95 heavy-duty poly roller for #63314 roller guide assembly	Machined aluminum	0.6693"	9831873
D422S	3"	13/16"	SPx80 Quiet Poly counterweight roller guide wheel	Steel	0.7874"	9872309
D422	3"	13/16"	HDx95 heavy-duty poly counterweight roller guide wheel	Steel	0.7874"	9872309
D423S	8"	1 1/4"	SPx80 Quiet Poly guide roller for #63190 & #63801 assemblies	Machined aluminum	0.7874"	9831824
D423	8"	1 1/4"	HDx95 heavy-duty poly guide roller, same as D423S	Machined aluminum	0.7874"	9831824



9701588
40158
Sheave
2 3/8" dia. Nylon
Relating Cable



9715447, 894aa1
Roller (3" O.D.) for
tachometer with 1/2" Shaft

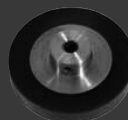

9766169
Roller (3" O.D.) for
Tachometer with 5/16" shaft



9861191
Upthrust Roller



9875426
Tire for Upthrust Roller



9811102
Sheave & Bracket
Assembly for Vertical Gate

Questions? Answers at...
(866) CED-ELEV • (866) 233-3538
www.cedlevator.com

Rollers Otis

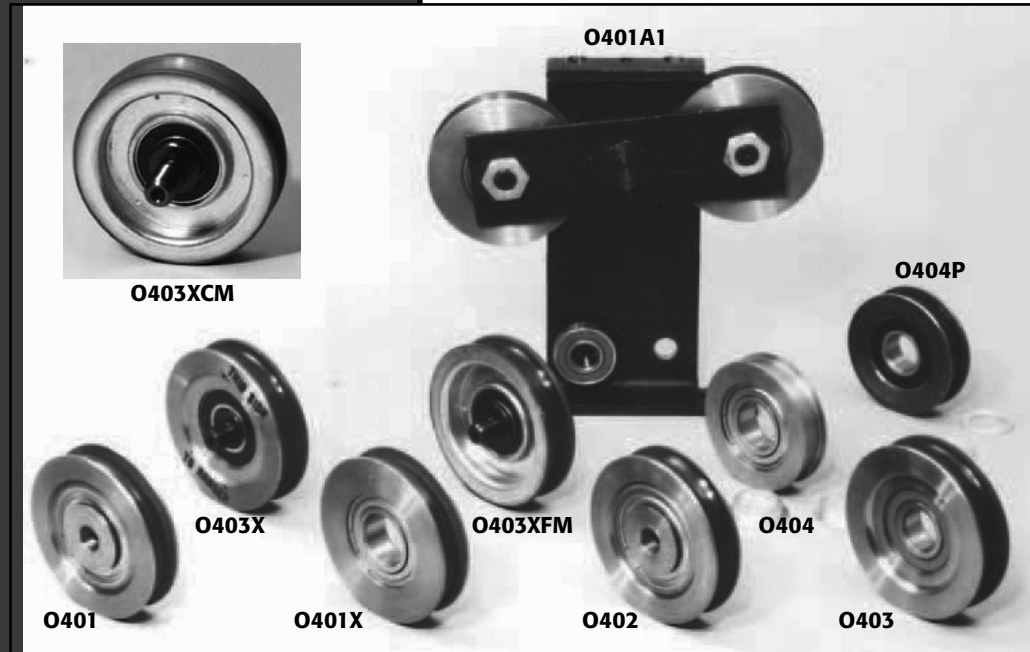

Part Number	Description	Roller Dimensions			Materials		Otis
		Diameter	Thickness	Bearing ID	Hub	Tire	Part Number
O401	Hanger roller with convex surface; for type AU & 6178A flat track hangers	3 1/4"	1 1/16"	0.500" (bushed)	Solid Steel	HDx ⁹⁵ ™ Poly	A456W1
O401HP	Same as O401, with low-friction hard poly	3 1/4"	1 1/16"	0.500" (bushed)	Solid Steel	LFx ⁷⁰ ™ Poly	A456W1
O401A1	Teeter-bar hanger with two O401 rollers and one O410 up-thrust roller; for heavy doors	3 1/4"	1 1/16"	0.500" (bushed)	Solid Steel	HDx ⁹⁵ ™ Poly	368203907
O401X	Hanger roller with convex tire surface; for Type "A" (6178A) hangers	3 1/4"	1 1/16"	0.9843"	Solid Steel	HDx ⁹⁵ ™ Poly	456W1
O402	Hanger roller for AU & 6178A hangers; concave roller surface	3 1/4"	1 1/16"	0.500"	Solid Steel	HDx ⁹⁵ ™ Poly	A456EA1
O402HP	Same as O402, with low-friction	3 1/4"	1 1/16"	0.500"	Solid Steel	LFx ⁷⁰ ™ Poly	A456EA1
O403	Hanger roller with 1 1/2" radius on concave surface	3 3/8"	1 3/16"	0.7874"	Solid Steel	HDx ⁹⁵ ™ Poly	456CX4
O403X	Hanger roller with eccentric axle stud, steel hub	3 3/8"	1 3/16"	n/a	Solid Steel	HDx ⁹⁵ ™ Poly	456DH1
O403XCM	Hanger roller, projection welded; eccentric axle has 1/2"-20 thread and 3/16" socket, machined hub	3 3/8"	1 3/16"	n/a	Machined Steel	HDx ⁹⁵ ™ Poly	456DH2
O403XFM	Hanger roller, projection welded; eccentric axle has 1/2"-20 thread and 3/16" socket, machined hub	3 3/8"	3/4"	n/a	Machined Steel	HDx ⁹⁵ ™ Poly	456EW1
O404	All-steel hanger roller for integral hoistway hanger	2 3/4"	1 1/16"	0.785"	Steel	Steel	456CC1
O404HP	Same as O404, with low-friction hard poly tire	2 3/4"	1 1/16"	0.785"	Steel	LFx ⁷⁰ ™ Poly	456CC1
O404P	Same as O404, with heavy-duty poly tire	2 3/4"	1 1/16"	0.785"	Steel	HDx ⁹⁵ ™ Poly	456CC1

Questions? Answers at...
 (866) CED-ELEV • (866) 233-3538
www.cedlevator.com

Rollers Schindler/Westinghouse

Replacement Wheels for
Westinghouse Guide Roller Assemblies

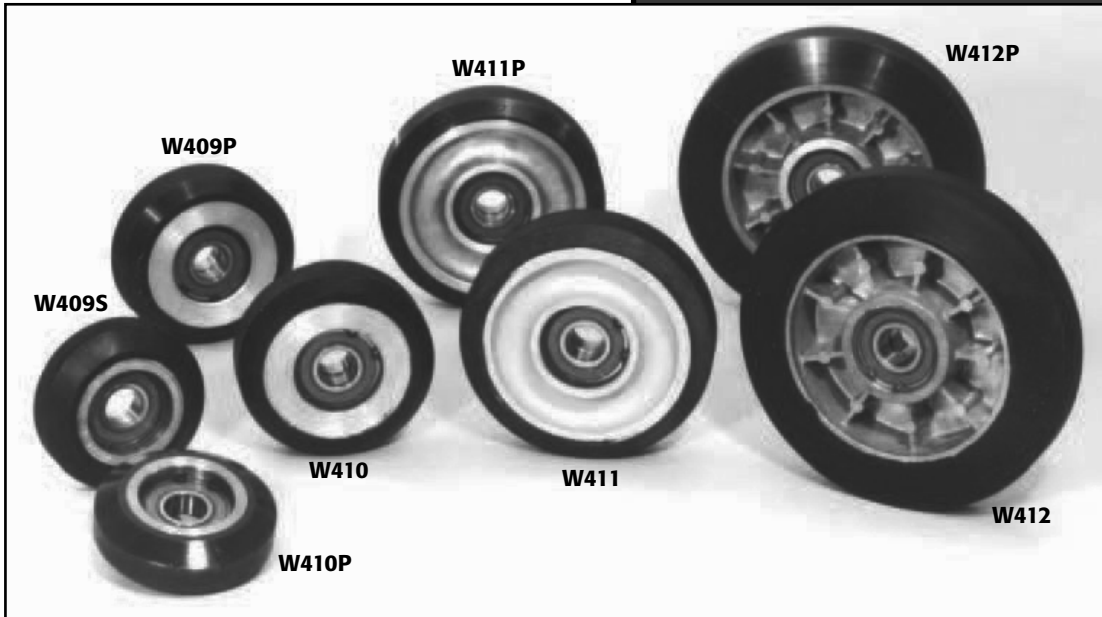

Part Number	Description	Diameter	Width	Tire Material	Bearing Bore	Westinghouse Part Number
W409P	Steel-hub counterweight roller guide wheel	3"	1.000"	HDx ⁹⁵ ™ poly	0.6693"	144A277G02
W409S	Steel-hub counterweight roller guide wheel	3"	1.000"	SPx ⁸⁰ ™ Quiet Poly	0.6693"	144A277G02
W410	Cast aluminum roller guide wheel	3½"	1.250"	Rubber	0.6693"	M5594G04
W410P	Cast aluminum roller guide wheel	3½"	1.250"	HDx ⁹⁵ ™ poly	0.6693"	M5594G04
W411	Cast aluminum roller guide wheel	4½"	1.250"	Rubber	0.6693"	M5594G02
W411P	Cast aluminum roller guide wheel	4½"	1.250"	HDx ⁹⁵ ™ poly	0.6693"	M5594G02
W411S	Cast aluminum roller guide wheel	4½"	1.250"	SPx ⁸⁰ ™ Quiet Poly	0.6693"	M5594G02
W412	Cast aluminum roller guide wheel	6"	1.200"	Rubber	0.6693"	323C160G01
W412P	Cast aluminum roller guide wheel	6"	1.200"	HDx ⁹⁵ ™ poly	0.6693"	323C160G02
W412S	Cast aluminum roller guide wheel	6"	1.200"	SPx ⁸⁰ ™ Quiet Poly	0.6693"	323C160G02
W416	Guide roller (not pictured)	10¼"	1.250"	Rubber	0.6693"	M5594G05
146A988H01	Shaft for face roller of 627D989G03 RGS ASSY (not pictured)					
576B710H01	Shaft for face roller of 627D989G03 RGS ASSY (not pictured)					

Color Key for Adams Poly
 Red = LFX80 Low Friction
 Black = SPx80 Soft
 Clear = HDx95 Heavy Duty

Questions? Answers at...
 (866) CED-ELEV • (866) 233-3538
www.cedlevator.com

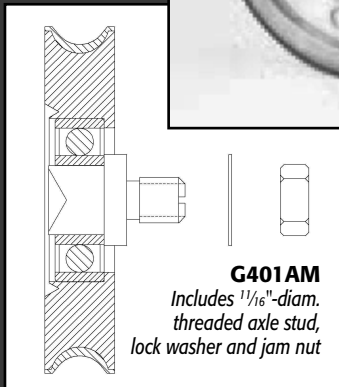
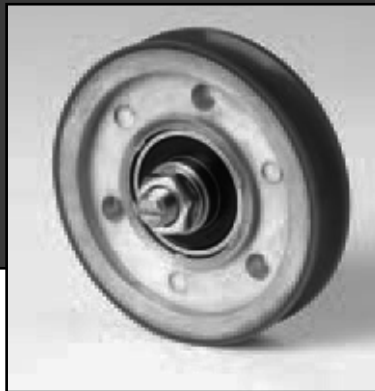

G.A.L. Door Operator Rollers

Replacement Rollers

You can count on the G401M for long life and reliability, and reduce the number of door-related call-backs while improving the overall quality of your G.A.L. installation.

- **Hubs:** Precision machined cast aluminum.
- **Tire:** Adams' own **low-friction LFX^{70TM} Durabond™ polyurethane** goes into every smooth- and quiet-running tire. LFX^{70TM} is as tough as any material now in use for door rollers. It resists breaking, cracking, and wear, and eliminates the need for a wiper.
- **Bearings:** Special low-friction bearings make the G401M one of the true "easy riders." To ensure concentricity and long life, rollers are machined after the bearings are installed.

Part Number	Description
G401M	Door hanger roller kit: includes (1) roller, (7) washers, and complete installation instructions. (Replaces G.A.L. NH roller kit.)
G401AM	Door hanger roller with axle stud

Replacement Wipers

Replacement felt wiper impregnated with light oil for superior cleaning action. *Not required with G401M superior-quality polyurethane tire.*

Part Number	Description	Units in Package
G401W	Replacement felt wiper for G.A.L. original roller (Replaces G.A.L. HH-1-2-E.)	1
G401WX	100-Pack of G401W wipers	100

Door Operators PMSSC with Board 1Ø4®

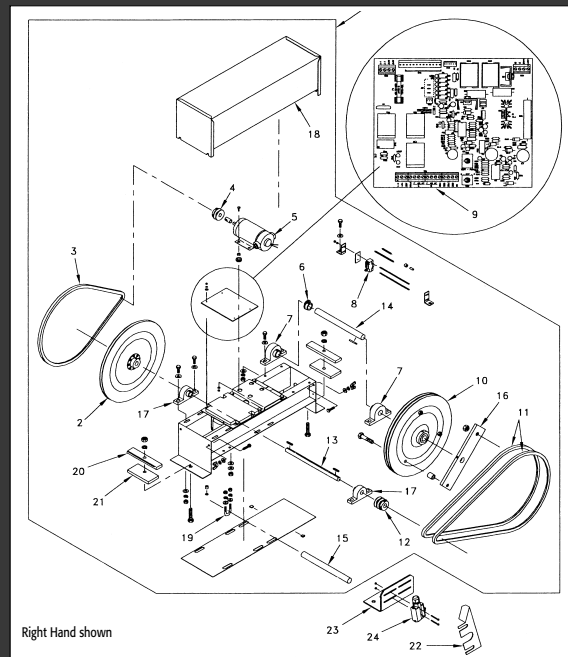

Key	Part Number	Part Name	Description
1	P-35011-001	Door operator, PM/SSC	Complete assembly; RH; with board 1Ø4
	P-35011-002	Door operator; PM/SSC	Complete assembly; LH with board 1Ø4
2	19502-029	Sheave, single	15¼ in. diameter
3	19501-021	Belt	4L 550 Frac hp V-type (A53)
4	19502-031	Sheave, single	1.7 in. pitch for reduction stage
5	101849	Motor, permanent magnet	1140 RPM, 24 VDC
6	25078	Cam, door operator	5 or 6 required
7	38351	Pillow block	1 in. bore
8	100165	Switch, micro	for PMSSC door operators
9	P-24783-001	PC board	Board 1Ø4 with relays, fuse, & instructions
10	19502-028	Sheave, double	15¼ in. diameter
11	19501-022	Belt	4L 680 Frac hp V-type (A66)
12	19502-030	Sheave, double	1.7 in.
13	25076	Shaft	¾ in. x 12 in. for reduction
14	25077	Shaft	Door operator camshaft
15	25075	Shaft, pivot	Door operator
16	25082-***	Crank arm, door operator	Factory drilled per listing, > 48"
	25082-001	Crank arm, door operator	Without drilling for crank bolt
	P-35035-001	Crank arm, door operator	Adjustable for all 30 to 48" openings
17	19500-032	Pillow block	¾ in. dia. bore
18	P-24186	Cover, door operator	
19	P-35008-001	U-bolt hardware bag	Includes U-bolt (101871), hex nuts (47401-003) and lockwashers (48731-003)
20	25089	Bar	
21	25090	Bar	
NS	46208	Transformer	32V 250VA; 2 required for high performance option
NS	46217-020	Rectifier, bridge	25A 200V
NS	46218	Capacitor, electrolytic	4500 uF, 50WV
NS	P-31364	Switch & cam assembly	Used for adding a switch
22	102023-001	Actuator, closure switch	RH
	102023-002	Actuator, closure switch	LH
23	102022-001	Fitting, mounting, closure switch	
24	P-35015-001	Microswitch assembly	Door closure switch

NS = Not Shown

Questions? Answers at...
(866) CED-ELEV • (866) 233-3538
www.cedelevator.com

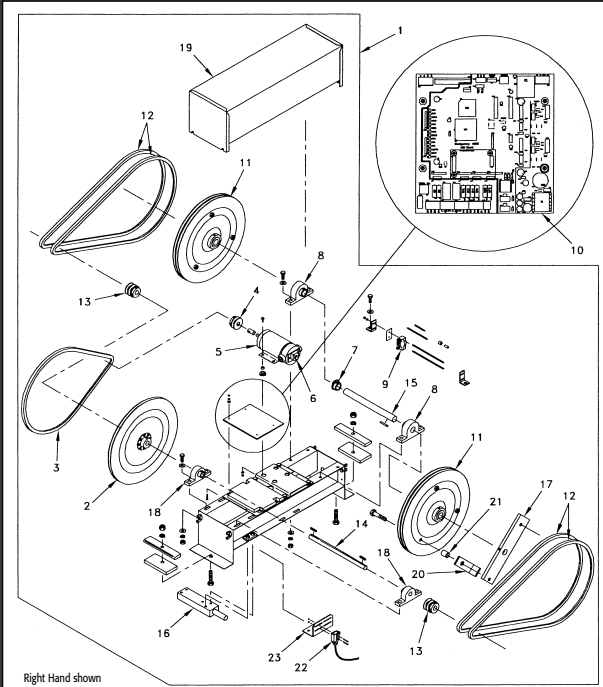

Door Operators Closed Loop

Key	Part Number	Part Name	Description
1	P-31947-001	Door operator, closed loop	Complete assembly, RH
	P-31947-002	Door operator, closed loop	Complete assembly, LH
2	19502-029	Sheave, single	15¼ in. diameter
3	19501-021	Belt	4L 550 Frac hp V-type (A53)
4	19502-031	Sheave, single	1.7 in. pitch for reduction
5	P-22442-001	Motor & encoder	Encoder shaft magnet
6	P-22444-001	Motor service kit	Inc. encoder, centering tool, space tool, hardware & instructions
7	25078	Cam, door operator	5 or 6 required
8	38351	Pillow block	1 in. bore
9	100165	Switch, micro	For PMSSC door operators
10	P-31872-003	PC board	Main board; closed loop door control
11	19502-028	Sheave, double	15¼ in. diameter
12	19501-022	Belt	4L 680 Frac hp V-type (A66)
13	19502-030	Sheave, double	1.7 in.
14	58819	Shaft	¾ in. for reduction
15	58820 Shaft	Door operator camshaft	
16	P-24187	Shaft, pivot assembly	
17	25082-***	Crank arm, door operator	Factory drilled per listing, > 48"
	25082-001	Crank arm, door operator	Without drilling for crank bolt
	P-35035-001	Crank arm, door operator	Adjustable for all 30 to 48" openings
18	19500-032	Pillow block	¾ in. dia. bore
19	P-24186	Cover, door operator	
20	95468-001	Bracket, stop angle	
21	95467-001	Spacer, drive sheave	
22	P-35015-001	Microswitch assembly	Door closure switch
23	102022-001	Fitting, mounting, closure switch	
NS	46208	Transformer high performance option	32V 250VA; 2 required for
NS	46217-020	Rectifier, bridge	25A 200V
NS	49732	Capacitor, electrolytic	41000 uF, 50WV for
		high performance power supply	
NS	P-31364	Switch & cam assembly	Used for adding a switch
NS	91651-002	Cable, motor encoder	Length = 24 inches

NS = Not Shown

Door Operators

Power Supplies, Switches & Motor

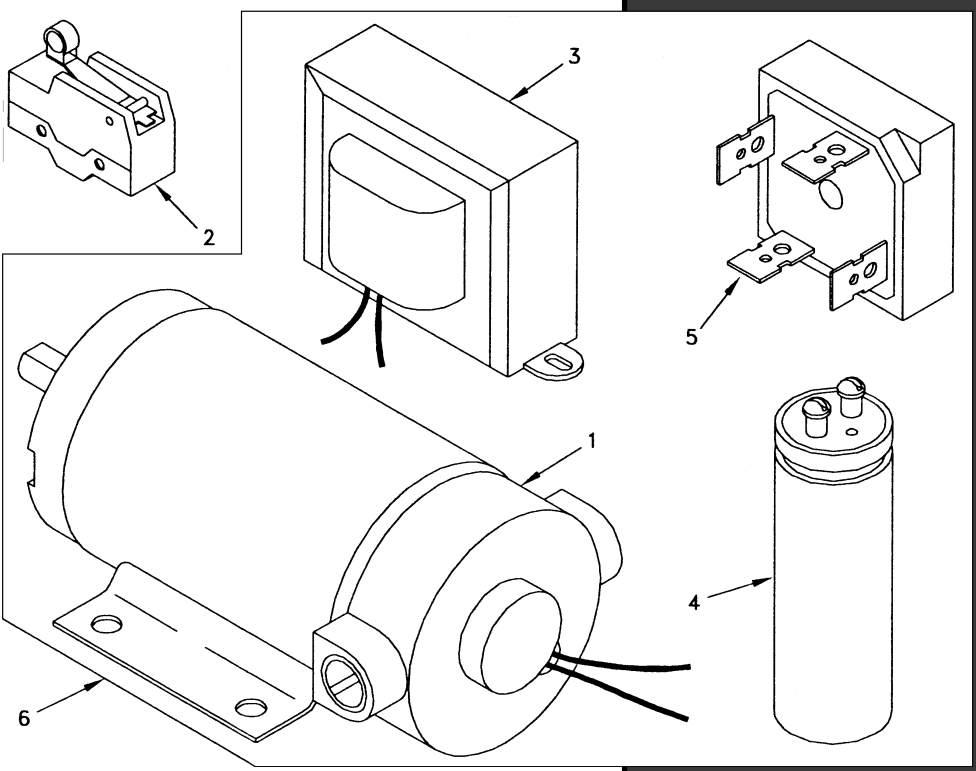

Key	Part Number	Part Name	Description
1	101849	Motor, permanent magnet	1140 RPM, 24 VDC
2	100165	Switch, micro	for PMSSC door operators
3	46208	Transformer	32V 250VA; 2 required for high performance option
4	46218	Capacitor, electrolytic	4500 uF, 50WV
	49732	Capacitor, electrolytic	41000 uF, 50WV for high performance power supply
5	46217-020	Rectifier, bridge	25A 200V
NS	90527-022	Cable	Replaces previously used cable P-15807
6	P-22267-001	Kit, conversion to solid state	To convert type M to PMSSC; includes motor, door control w/Board 1Ø4, and cover

The above listed parts are for all PMSSC and HPM door operators.
 When replacing older four-board systems, use cable assembly 90527-022 to replace wires on existing common board.
 NS = Not Shown

Questions? Answers at...
 (866) CED-ELEV • (866) 233-3538
www.cedlevator.com

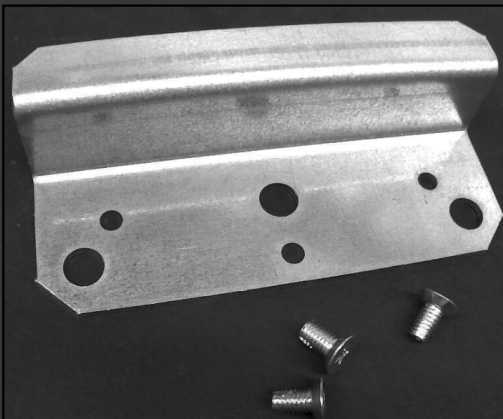
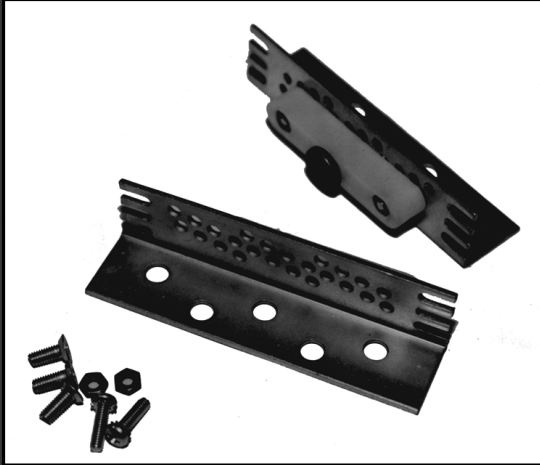

Door Gibs & Fire Tabs

Door Gibs

Standard Package Includes:

- (1) Nylon Gib
- (1) Chassis
- (1) Hardware Set:
 - 2 PCs-6/32x3/8 #8HD Slot binding M/S/ SMES w/ Inter Lock Washers zinc plated
 - 2 PCs 6/32 Safety Studs zinc plated
 - 3 PC Mounting Screws 10/32x1/2 Phil Flat Undercut type "F" zinc plated

Part Number	Chassis		Description
	Width	Adjustments	
G1532-118	1 1/8"	10	1 5/32" wide white nylon gib
G1532-114	1 1/4"	12	1 5/32" wide white nylon gib
G1732-118	1 1/8"	10	1 7/32" wide green nylon gib
G1732-114	1 1/4"	12	1 7/32" wide green nylon gib
G12-118	1 1/8"	10	1/2" wide blue nylon gib
G12-114	1 1/4"	12	1/2" wide blue nylon gib
G716-118	1 1/8"	10	7/16" wide black nylon gib
G716-114	1 1/4"	12	7/16" wide black nylon gib

Roller bearing door gib for extended door operation life. Eliminates door side play. Specify chassis width when ordering: 7/8", 1", 1 1/8", or 1 1/4"

NYLUBE CROSS REFERENCE

YELLOW	= 3/8"
GREEN	= 15/32"
RED	= 7/16"
WHITE	= 1/2"
BLUE	= 17/32"

Door Astragal and Holder

Compatible with part number A132 (astragal rubber). Door Astragal is included. 7' lengths.

Part Number	Description
DAA	Aluminum
DAAB	Anodized Bronze
A132-DAA	Replacement astragal for DAA holder

Other sizes available.

Fire Safety Door Stops

Part Number	Description
NY-949-K1	Fire Stop Door Gib 5/8" Offset
NY-949-K2	Fire Stop Door Gib 3/4" Offset
NY-949-K3	Fire Stop Door Gib 7/8" Offset
NY-949-K9	Fire Stop Door Gib 3/8" Offset

Spirators Door Bumpers

Universal Standard- & Heavy-Duty Spirators

True universal mounting format in two long-lasting models

Choose from two models of reel-type door closers with universal hub design. Both models include retaining ring and nylon washer.

Heavy-duty Spirator

Comes complete with a heavy-duty rewind tension spring and heavy-duty cable terminal for use with heavy elevator doors.

Standard-duty spirator

Works best with light- to middle-weight doors.

Square-Peg Mounting Bracket

This mounting bracket with "snake eyes" works with either model. It also mounts spirators from other manufacturers.

Part Number	Description
A831	5"-dia. heavy-duty spirator with heavy-duty rewind tension spring and cable terminal.
A832	5"-dia. standard-duty spirator w/nylon runner.
W832	6"-dia. standard-duty spirator w/nylon runner.
A831B	Mounting bracket for Adams and other spirators.

Door Bumpers

The economical way to silence closing elevator doors

Self-adhesive bumper pads attach to door jamb, and stay put. They take the hit of noisy doors as they close, and deaden the sound. No more metal against metal.

Sold in strips of 36 self adhesive bumpers. Just peel off from the backing strip and press into place.

Part Number **A770**

SmarTork Spirators

SmarTork™ revolutionary design overcomes wind velocities on elevator hoistway doors by increasing tension by 20% during the last 2 inches of closing.

Over 1,000,000 cycles show no significant deviations from torque and tension ratios.

SmarTork's universal hub makes it interchangeable with most square shaft or dual pin mounting brackets.

Part Number: **SMARTORK**

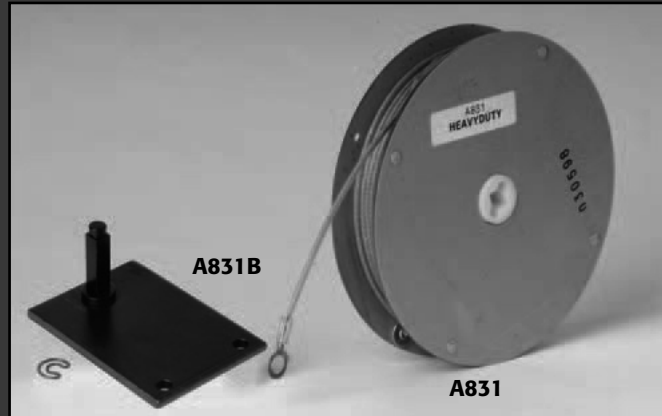

Questions? Answers at...
 (866) CED-ELEV • (866) 233-3538
www.cedelevator.com

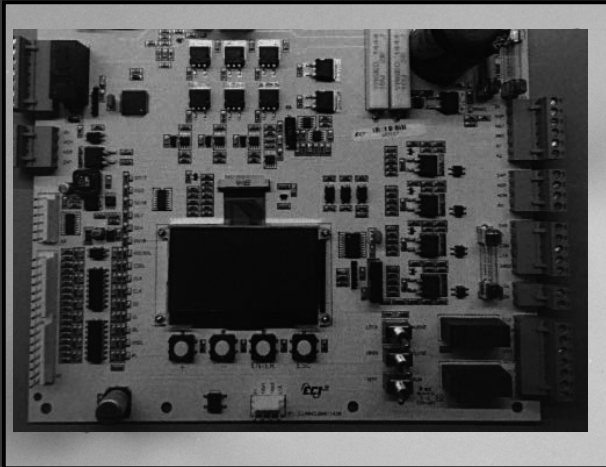

ECIA04500011420
ECI CANADA (GAL) DOOR
BOARD 1000-3050 & 3050-1

ECI Door Boards

Board 109LCD

"The next generation in the Wizard series of door boards"
ECI Board 109 series of door boards are not just direct replacements, they are technically superior offering state of the art performance with additional features and benefits over the existing original equipment. The 109 series of boards will replace any MAC 104, MAC 105 or previous 3-board groupings in either open or closed loop applications.

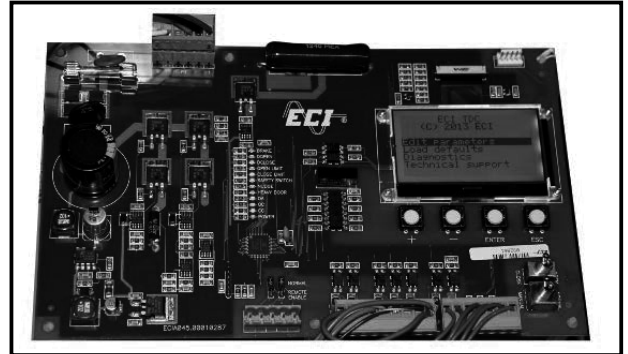

ECIA04500010287
SCHINDLER QKS-TRDC-LCD
REPLACEMENT DOOR BOARD

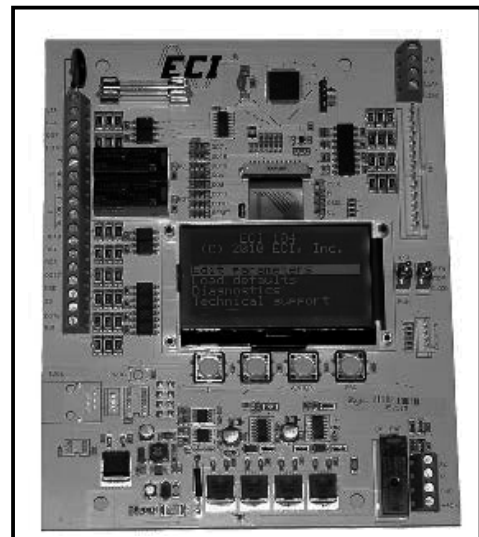

109-4
MAC 104 DOOR BOARD,
REPLACES P-24783-XXX
109-5
MAC/KONE 105 DOOR BOARD,
REPLACES P-31872-XXX

Door Straps

Heavy Duty Door Pull Straps

Our 12,000lb. test heavy-duty door pull straps are made of durable black nylon. A mounting bracket is sewn into one end for attachment.

Part Number	Length	Part Number	Length
HDP18	18"	HDP24	24"
HDP30	30"	HDP36	36"
HDP48	48"		



ELECTRICAL & INDUSTRIAL PRODUCTS

5

In this Section

String Lights	5.2
Bulbs, Lights & Lamp Guards	5.2
Specialty & Flash Lights	5.2
Pendant Station	5.3
Limit Switches & Sensors	5.4-5.5
Pit Switches, Outlets & Work Lights	5.6
Auxiliary Convenience Boxes	5.6
EMT Tubing, Fittings & Accessories	5.7
EMT Connectors & Couplings	5.8
EMT Access Fittings	5.9
Flexible Metal Fittings	5.10
EMT-to-Flex Couplings	5.10
Liquid Tight Fittings	5.10
Boxes, Covers & Plugs	5.11-12
3 Piece Knockouts/Knockout Plugs	5.12
Mechanical & Compression Lugs	5.13
Split-bolt Connectors	5.13
Tabs, Forks and Rings	5.13
Polaris Connectors	5.13
Insulated Butt Splices	5.14
ScotchLok® Components	5.14
Wire Nuts	5.14
Ty-Raps	5.14
Wire Marker Cards & Dispensers	5.14
Channel & Components	5.15
Screws & Fasteners	5.15
Cush Clamps	5.15

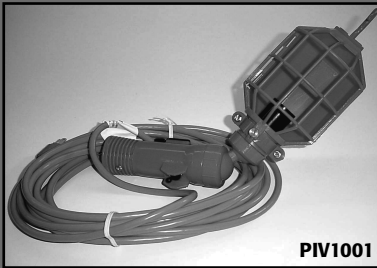
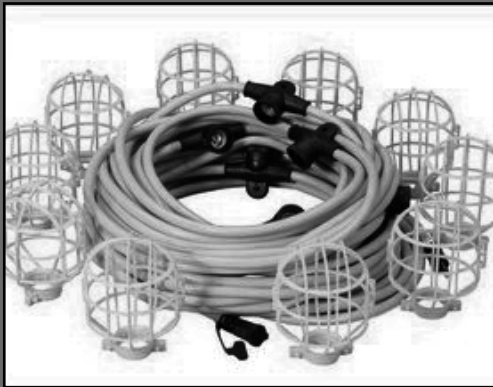

PIV1001

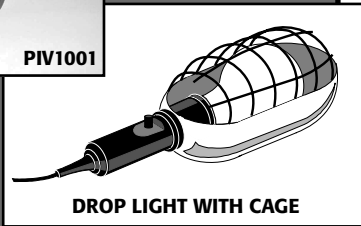

DROP LIGHT WITH CAGE



2250S



2100A



Extension Cords Bulbs, Lights, Lamp Guards

String Lights

Part No	Mfg	Description	No. Sockets
TL550	Lind	50' String Light w/ Plastic Guard	5
TL5100	Lind	100' String Light w/ Plastic Guard	10

Bulbs

Part Number	Mfr.	Description	Standard Packaging*
100ARS	GE	100-watt rough service bulbs	60
75ASL	GE	75-watt safety coated bulbs	24

Lights

Part Number	Mfr.	Description	Standard Packaging*
282	PS	Porcelain fixture with pull chain	1

Drop lights – various available, call for details

Guards & Cages

Part Number	Mfr.	Description	Standard Packaging*
21002100A	McGill	Metal cage	1
2259	McGill	Plastic cage	1
2250S	McGill	Plastic cage with steel screw	1

Flashlights

A variety of sizes available, call for details.

Questions? Answers at...

Western US: 866 CED-ELEV Eastern US: 866-253-2915
or 866-233-3538 • Fax 562-427-8429 or 860-256-2211 • Fax 860-290-8970

Pendant Stations

Pendant Station, 10ft. Cable

This water resistant pendant station comes with an up, down, common, and emergency stop button, as well as a key switch. The pendant comes prewired with a 10-ft. length of 18-gauge 8 conductor wire. Additional lengths are available upon request. Cut-to-length cable available in 18/6, 18/7 and 18/10. Part Number **PL05.MT2+**



Temporary Run Pendant Station

- 2-hand control via spring return safe selector
- Momentary Up/down Buttons & maintained emergency stop
- Comes as shown, pre-wired with 25' 18/5 SO cord & Insulated alligator clips

Part Number **CYTLP4S001**



This unit sold in the appropriate jurisdictions.

Questions? Answers at...

Western US: 866 CED-ELEV Eastern US: 866-253-2915
or 866-233-3538 • Fax 562-427-8429 or 860-256-2211 • Fax 860-290-8970



WLSE-NC

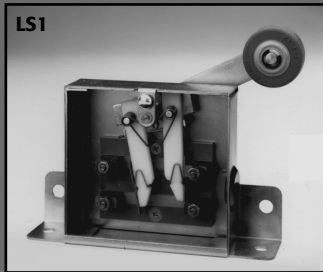

LS1

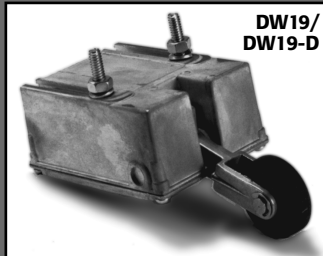

LS1-L

DW19/
DW19-D

Microswitch Switches & Sensors

Part Number	Description
BA2RV22	Short Roller Lever Snap Switch
BZ2RA	Pin Plunger Snap Switch
BZ2RW80A2	Bushing Mnt Plunger Snap Switch
BZ2RW8255A2S	Long Roller Lever Snap Switch
BZE62RN7S	Plunger Type Limit Switch w/Boot
BZE62RQ & BZE62RQ125	Roller Lever Limit Switches
BZE62RQ62	Low Force Rod Lever Limit Switch
5PA2	Snap Switch Terminal Cover
MC7711	Bushing Mount Plunger Assembly
103SR12A2 & 103SR12A7	Cylindrical Hall Effect Sensors
121XK212	Ferrous Metals Sensitive Prox



Limit Switches & Sensors

WLSE-NC

- Westinghouse Type E. Direct replacement for manufacturers switch. One normally closed contact.

LS1, LS1-L

- Direct replacement for C.J. Anderson, Maxton, and Virginia controls limit switches.
- Rubber roller for dependable operation
- Contacts self-wiping, maintenance-free, copper to carbon. See-through cover.
- One set normally open, one set normally closed.

EECO LS1B Limit Switches

DW19

- Specifically for use in the elevator hatchway as zoning, normal, and final limits
- One set normally open, one set normally closed.

DW19-D

- Double contact switch

Omron Limit Switches

Heavy-duty positive opening contacts. Contacts side rotary mechanical life 30 million operations.

CD4B-3111N

- Single Pole, 1N.O., 1N.C.
- Nylon roller lever, (.69" Dia.).

D4B-4113N-NPT

- Single Pole, 1N.O., 1N.C.
- Adjustable roller lever, rubber, (1.97" Dia.).

D4B-4A13N-NPT

- Double Pole, 2 N.C.
- Adjustable roller lever, rubber, (1.97" Dia.).



CD4B

Questions? Answers at...

Western US: 866 CED-ELEV Eastern US: 866-253-2915
or 866-233-3538 • Fax 562-427-8429 or 860-256-2211 • Fax 860-290-8970

Limit Switches

Part Number	Description	Otis Part #	Contact	Figure
S6098NM1	LIMIT SWITCH WITH CLEAR COVER, LEFT HAND OPERATION WITH ROLLER ARM	AAA6098NM1	SINGLE POLE BREAKING / (1NC)	A
S6098NM2	LIMIT SWITCH WITH CLEAR COVER, RIGHT HAND OPERATION WITH ROLLER ARM	AAA6098NM2	SINGLE POLE BREAKING / (1NC)	B
S6098NM3	LIMIT SWITCH WITH CLEAR COVER, LEFT HAND OPERATION WITH ROLLER ARM	AAA6098NM3	DOUBLE POLE BREAKING / (2NC)	C
S6098NM4	LIMIT SWITCH WITH CLEAR COVER, RIGHT HAND OPERATION WITH ROLLER ARM	AAA6098NM4	DOUBLE POLE BREAKING / (2NC)	D
S6098NM8	LIMIT SWITCH WITH CLEAR COVER, LEFT HAND OPERATION WITH ROLLER ARM	AAA6098NM8	SINGLE POLE MAKING / (1NO)	E
S6098NM9	LIMIT SWITCH WITH CLEAR COVER, RIGHT HAND OPERATION WITH ROLLER ARM	AAA6098NM9	SINGLE POLE MAKING / (1NO)	F
S6098NM10	LIMIT SWITCH WITH CLEAR COVER, LEFT HAND OPERATION WITH ROLLER ARM	AAA6098NM10	DOUBLE POLE MAKING / (2NO)	G
S6098NM11	LIMIT SWITCH WITH CLEAR COVER, RIGHT HAND OPERATION WITH ROLLER ARM	AAA6098NM11	DOUBLE POLE MAKING / (2NO)	H
A6098A1	FLOOR STOP SWITCH	A6098A1	SPDT, w/AUX CONTACTS	I
A6098A3	FLOOR STOP SWITCH	A6098A3	DPST, MAINTAINED, CONTACTS MAKE WHEN ROLLER MOVES LEFT	J
A6098A4	FLOOR STOP SWITCH	A6098A4	DPST, MAINTAINED, CONTACTS MAKE WHEN ROLLER MOVES RIGHT	K
6098E5	CAR GATE SWITCH, LEFT HAND LEVER	6098E5	DOUBLE POLE MAKING / (2NO)	L
6098E6	CAR GATE SWITCH, RIGHT HAND LEVER	6098E6	DOUBLE POLE MAKING / (2NO)	M
A6098	CM2 CAR TOP SWITCH	A6098CM2	SINGLE POLE MAKING / (1NO)	N
SND4118-SL-A	SUNS OIL TIGHT LIMIT SWITCH, PLASTIC BODY, 4 X 90 DEG ADJUSTABLE HEAD, ADJUSTABLE LEVER W/1.5" RUBBER ROLLER, 0.50" NPT HUB		1 NO & 1 NC	O
XCKS149H7	SCHNEIDER OIL TIGHT LIMIT SWITCH, PLASTIC BODY, 4 X 90 DEG ADJUSTABLE HEAD, ADJUSTABLE LEVER W/1.5" RUBBER ROLLER, 0.50" NPT HUB		2 NO & 1 NC	P
9007C54B2	SCHNEIDER OIL TIGHT LIMIT SWITCH, CAST BODY, 4 X 90 DEG ADJUSTABLE HEAD, ADJUSTABLE LEVER W/1.5" RUBBER ROLLER, 0.50" NPT HUB		SPDT-DB	Q
9007C62B2	SCHNEIDER OIL TIGHT LIMIT SWITCH, CAST BODY, 4 X 90 DEG ADJUSTABLE HEAD, ADJUSTABLE LEVER W/1.5" RUBBER ROLLER, 0.50" NPT HUB		DPDT	R
9007EA1	3" FIXED LENGTH LEVER ARM, 5/8" STEEL ROLLER			S
9007HA1	7/8" TO 4" ADJUSTABLE LENGTH LEVER ARM, 5/8" STEEL ROLLER			T
D4B-4113N-NPT	OMRON OIL TIGHT LIMIT SWITCH, 4 X 90 DEG ADJUSTABLE HEAD, ADJUSTABLE LEVER W/1.5" RUBBER ROLLER, M20 HUB W/ 0.50" NPT ADAPTER		1 NO & 1 NC	U
D4B-4A13N-NPT	OMRON OIL TIGHT LIMIT SWITCH, 4 X 90 DEG ADJUSTABLE HEAD, ADJUSTABLE LEVER W/1.5" RUBBER ROLLER, M20 HUB W/ 0.50" NPT ADAPTER		2 NC, SLOW BREAK	V



A



B



C



D



E



F



G



H



I



J



K



L



M



N



O

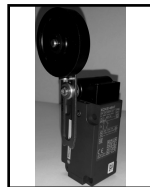

P



Q



R



S



T



U



V

Questions? Answers at...

Western US: 866 CED-ELEV Eastern US: 866-253-2915
 or 866-233-3538 • Fax 562-427-8429 or 860-256-2211 • Fax 860-290-8970

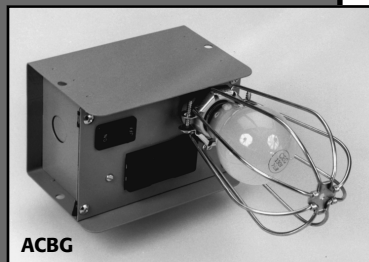
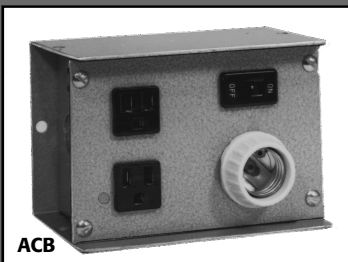
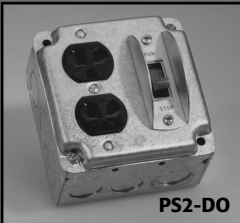

Pit Switches, Outlets, Lights & Convenience Boxes

Pit Switches

All Models are designed to meet ANSI A17.1 Rules 106.1f and 210.2e/2g Elevator Safety Code Requirements. Red run/stop control switch conforms to Rule 210.2e(4).

PS2

- Steel guard prevents damage or accidental switching
- Switch rated 20 amps at 250 VAC
- Lockable

PS3

- Run/stop in 1/2" permanent raised letters
- Cast aluminum cover
- CSA approved (CSA B44, B44.1/ASME, A17.1, A17.5)

PS2-DC

- Heavy Duty rocker switch
- Switch rated 1.5 amps at 120 VDC

PS4

- Push To Stop/Pull To Run
- One normally closed contact
- Maintained in both positions

Pit Switches/Outlets

PS2-DO

- With duplex outlet
- Padlockable

PS2-GFI

- With Ground Fault Circuit Interrupter
- Padlockable

Pit Work Lights

PWL

- Pit work light for pit or under car
- Light socket
- Light switch
- 4" x 4" x 2 1/2" box
- 120V outlet

PWLG

- With Ground Fault Circuit Interrupter
- 4 3/4" x 4 3/4" x 2 1/2" box

Auxiliary Convenience Boxes

ACB

Under cab work light, designed with two 3-prong electric cord outlets, light switch, and ceramic incandescent light bulb socket. Pre-drilled mounting brackets ensure easy installation.

ACBG

Ground Fault Circuit Interrupter provided in place of 3-prong outlets. (Shown with optional metal lamp guard and rough service lamp)

Questions? Answers at...

Western US: 866 CED-ELEV Eastern US: 866-253-2915
 or 866-233-3538 • Fax 562-427-8429 or 860-256-2211 • Fax 860-290-8970

EMT Tubing, Fittings & Accessories

EMT Tubing

Part Number	Diameter inches	Standard Packaging*
Per description	1/2	10
"	3/4	10
"	1	10
"	1 1/4	10
"	1 1/2	10
"	2	10
"	2 1/2	10

90° EMT Elbows (lt.wt., thin wall, UL listed)

Part Number	Diameter inches	Standard Packaging*
Per description		
"	1/2	25
"	3/4	25
"	1 1/4	20
"	1 1/2	10
"	2	10
"	2 1/2	1

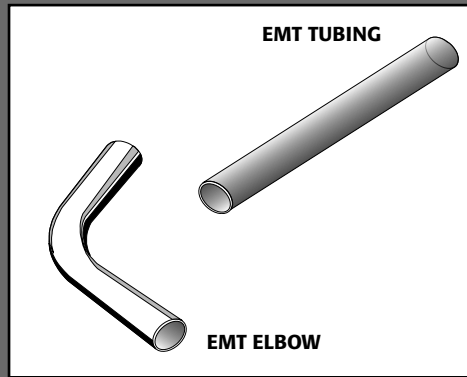

One-hole EMT Straps

Part Number	Diameter inches	Standard Packaging*
MED30	1/2	100
MED45	3/4	100
MED55	1	50
MED65	1 1/4	50
MED75	1 1/2	25
MED85	2	20

EMT Hangers with bolts (UL listed)

Part Number	Diameter inches	Standard Packaging*
0B	1/2	100
1B	3/4	100
2B	1	100
2 1/2B	1 1/4	100
3B	1 1/2	100
5B	2	50

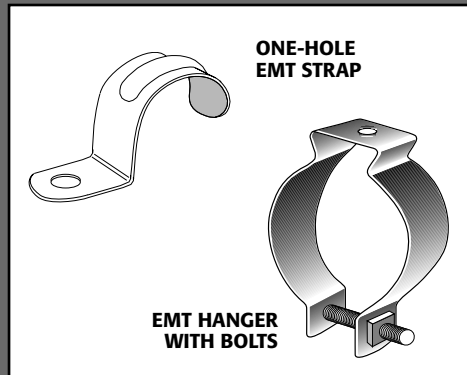

Larger sizes available if needed.

Die-cast Chase Nipples (UL listed, CSA certified)

Part Number	Diameter inches	Standard Packaging*
1102DC	1/2	100
1103DC	3/4	100
1104DC	1	50
1105DC	1 1/4	25
1106DC	1 1/2	25
1107DC	2	15
1108DC	2 1/2	5
1109DC	3	5

Steel Lock Nuts (UL listed, CSA certified)

Part Number	Diameter inches	Standard Packaging*
101S	1/2	100
102S	3/4	100
103S	1	100
104S	1 1/4	50
105S	1 1/2	50
106S	2	25
107S	2 1/2	10
108S	3	10

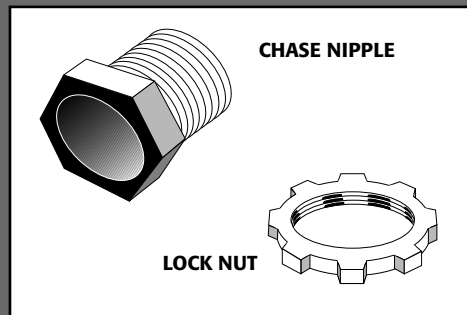

Larger sizes available if needed.

Threaded Plastic Insulated Bushings (UL listed, CSA certified)

Part Number	Diameter inches	Standard Packaging*
321	1/2	100
322	3/4	100
323	1	50
324	1 1/4	25
325	1 1/2	25
326	2	10
327	2 1/2	10
328	3	10

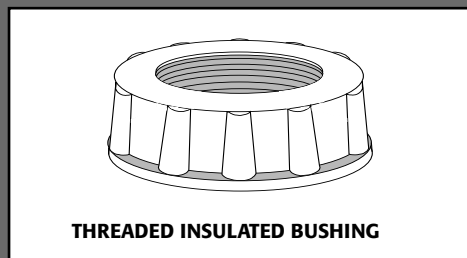

Larger sizes available if needed.

*All items may be purchased individually.

Questions? Answers at...

Western US: 866 CED-ELEV Eastern US: 866-253-2915
or 866-233-3538 • Fax 562-427-8429 or 860-256-2211 • Fax 860-290-8970

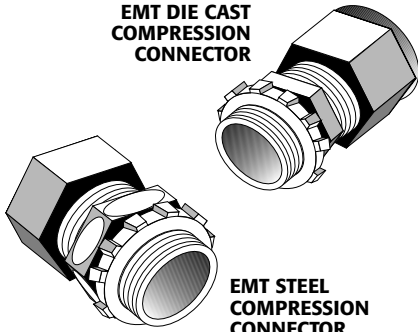
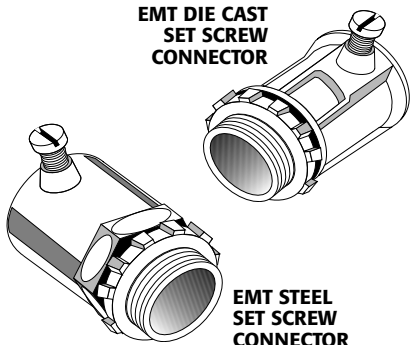
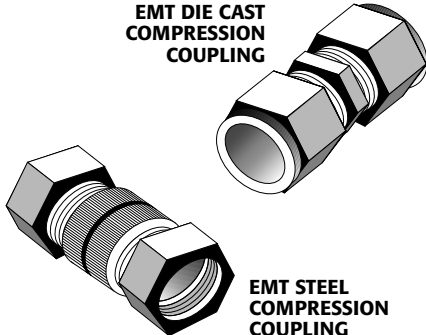
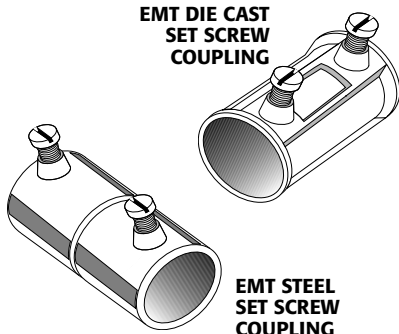
**EMT DIE CAST
COMPRESSION
CONNECTOR**

**EMT STEEL
COMPRESSION
CONNECTOR**
**EMT DIE CAST
SET SCREW
CONNECTOR**

**EMT STEEL
SET SCREW
CONNECTOR**
**EMT DIE CAST
COMPRESSION
COUPLING**

**EMT STEEL
COMPRESSION
COUPLING**
**EMT DIE CAST
SET SCREW
COUPLING**

**EMT STEEL
SET SCREW
COUPLING**

EMT Connectors & Couplings

EMT Compression Connectors: Die-cast & Steel

Part Number	Diameter inches	Standard Packaging*	Part Number	Diameter inches	Standard Packaging*
250DC2	1/2	50	250	1/2	50
251DC2	3/4	25	251	3/4	25
252DC2	1	15	252	1	25
253DC2	1 1/4	10	253	1 1/4	10
254DC2	1 1/2	10	254	1 1/2	10
255DC2	2	10	255	2	10
256DC2	2 1/2	12	256	2 1/2	2
257DC2	3	12	257	3	2

EMT Set Screw Connectors: Die-cast & Steel

Part Number	Diameter inches	Standard Packaging*	Part Number	Diameter inches	Standard Packaging*
230DC2	1/2	100	230	1/2	50
231DC2	3/4	50	231	3/4	25
232DC2	1	10	232	1	20
233DC2	1 1/4	10	233	1 1/4	10
234DC2	1 1/2	10	234	1 1/2	10
235DC2	2	5	235	2	5
236DC2	2 1/2	12	236	2 1/2	2
237DC2	3	12	237	3	2

EMT Compression Couplings: Die-cast & Steel

Part Number	Diameter inches	Standard Packaging*	Part Number	Diameter inches	Standard Packaging*
260DC	1/2	50	260	1/2	50
261DC	3/4	25	261	3/4	25
262DC	1	10	262	1	25
263DC	1 1/4	10	263	1 1/4	10
264DC	1 1/2	10	264	1 1/2	10
265DC	2	5	265	2	5
266DC	2 1/2	12	266	2 1/2	2
267DC	3	12	267	3	2

EMT Set Screw Connectors: Die-cast & Steel

Part Number	Diameter inches	Standard Packaging*	Part Number	Diameter inches	Standard Packaging*
240DC	1/2	50	240	1/2	50
241DC	3/4	25	241	3/4	25
242DC	1	25	242	1	20
243DC	1 1/4	10	243	1 1/4	150
244DC	1 1/2	10	244	1 1/2	10
245DC	2	10	245	2	5
246DC	2 1/2	12	246	2 1/2	2
247DC	3	12	247	3	2

*All items may be purchased individually.

Questions? Answers at...

Western US: 866 CED-ELEV Eastern US: 866-253-2915
 or 866-233-3538 • Fax 562-427-8429 or 860-256-2211 • Fax 860-290-8970

EMT Access Fittings

Type LB Threaded (with cover and gasket)

Part Number	Size inches	Standard Packaging*
LB50CG	1/2	10
LB75CG	3/4	10
LB100CG	1	5
LB125CG	1 1/4	2
LB150CG	1 1/2	2
LB200CG	2	1

Type LR Threaded (with cover and gasket)

Part Number	Size inches	Standard Packaging*
LR50CG	1/2	10
LR75CG	3/4	10
LR100CG	1	5
LR125CG	1 1/4	2
LR150CG	1 1/2	2
LR200CG	2	1

Type LL Threaded (with cover and gasket)

Part Number	Size inches	Standard Packaging*
LL50CG	1/2	10
LL75CG	3/4	10
LL100CG	1	5
LL125CG	1 1/4	2
LL150CG	1 1/2	2
LL200CG	2	1

Covers for Type LB, LR and LL Access Fittings

Part Number	Fits Size inches	Standard Packaging*
K50A	1/2	50
K75A	3/4	50
K100A	1	50
K125A/150A	1 1/4 to 1 1/2	25
K200A	2	25

*All items may be purchased individually.

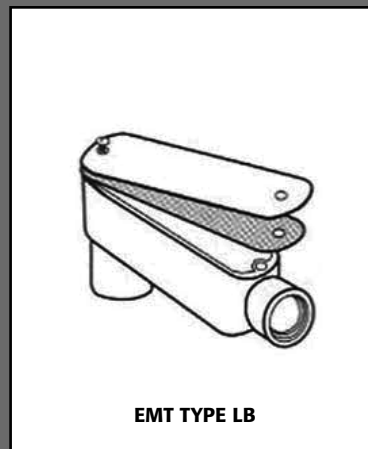

EMT TYPE LB

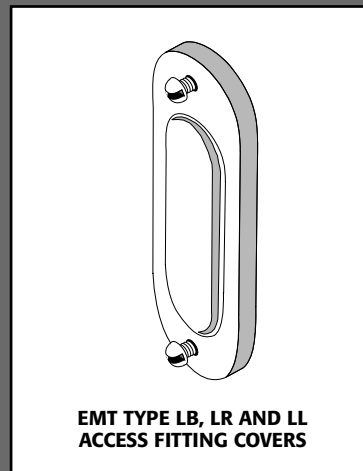

EMT TYPE LB, LR AND LL ACCESS FITTING COVERS

Questions? Answers at...

Western US: 866 CED-ELEV Eastern US: 866-253-2915
or 866-233-3538 • Fax 562-427-8429 or 860-256-2211 • Fax 860-290-8970

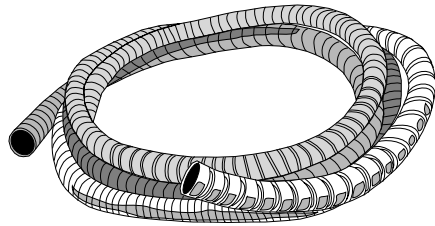
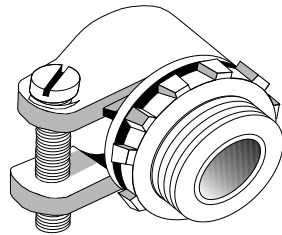
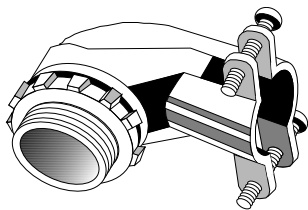
FLEXIBLE STEEL & ALUMINUM CONDUIT

STEEL STRAIGHT BOX CONNECTOR

STEEL 90° BOX CONNECTOR

**EMT-TO-FLEX DIE-CAST
SET SCREW COUPLING**

LIQUID TIGHT CONNECTORS IN STRAIGHT, 45° AND 90°

Flexible Metal Fittings & EMT-to-Flex Couplings

Flexible Steel/Aluminum Conduit (UL listed)

Part Number	Diameters inches	Standard Packaging*
Per desc.	3/8	100' reel
"	1/2	100' reel
"	3/4	100' reel
"	1	50' coil
"	1 1/4	50' coil
"	1 1/2	25' coil
"	2	25' coil

Straight Squeeze-Malleable Iron Flex Box Connectors (UL listed)

Part Number	Diameters inches	Standard Packaging*
7481V	1/2	25
7482V	3/4	25
7483	1	10
7484	1 1/4	10
7485	1 1/2	5
7486	2	4

90° Squeeze-Zinc Die Cast Flex Box Connectors (UL listed and CSA certified)

Part Number	Diameters inches	Standard Packaging*
804DC2	1/2	25
806DC2	3/4	10
807DC2	1	25
808DC2	1 1/4	25
809DC2	1 1/2	5
810DC2	2	5

Compression/Screw-on

Part Number	Diameters inches	Standard Packaging*
581DC	1/2 EMT to 1/2 FLEX	50
582DC	3/4 EMT to 3/4 FLEX	25
583DC	1 EMT to 1 FLEX	20

*All items may be purchased individually.

Liquid Tight Connectors

Dimensions	Straight	45°	90°
1/2"	ST50	ST4550	ST9050
3/4"	ST75	ST4575	ST9075
1"	ST100	ST45100	ST90100
1 1/4"	ST125	ST45125	ST90125
1 1/2"	ST150	ST45150	ST90150
2"	ST200	ST45200	ST90200
2 1/2"	ST250	ST45250	ST90250
3"	ST300	ST45300	ST90300

Boxes & Covers

4" x 4" Square Boxes:

1 1/2" deep (type 52151)

Part Number	Knockouts inches	Standard Packaging*
4SBMKO	1/2 & 3/4	50

2 1/8" deep (type 52171) [UL listed]

Part Number	Knockouts inches	Standard Packaging*
4SDMKO	1/2 & 3/4	24

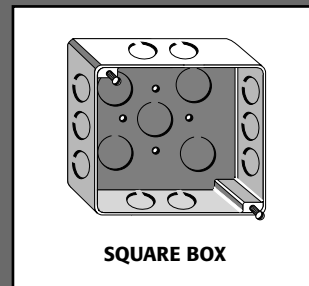

SQUARE BOX

4" x 2 1/8" Utility Boxes:

1 7/8" deep (type 58361)

Part Number	Knockouts inches	Standard Packaging*
HB150	1/2	50

2 1/8" deep (type 58371) [UL listed]

Part Number	Knockouts inches	Standard Packaging*
HDB150	1/2	50
HDB150MKO	3/4	50

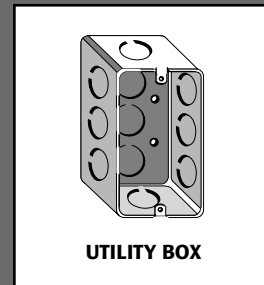

UTILITY BOX

4 11/16" Square Boxes: 2 1/8" deep (type 72171) [UL listed]

Part Number	Knockouts inches	Standard Packaging*
5SDB50/75	1/2 & 3/4	24
5SDBMKO	3/4 & 1	24

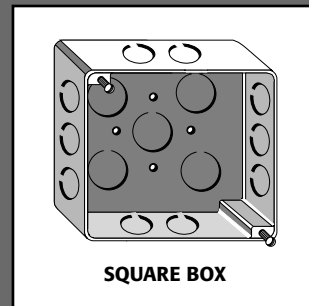

SQUARE BOX

4" Octagonal Boxes:

1 1/2" deep (type 54151)

Part Number	Knockouts inches	Standard Packaging*
4RB50	1/2	50

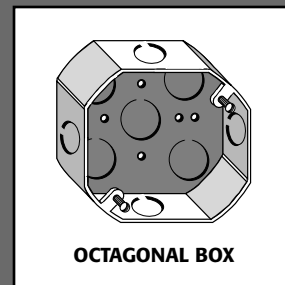

OCTAGONAL BOX

Box Covers/Flat Blank (UL listed and CSA certified)

Part Number	Knockouts inches	Standard Packaging*
4BC	4 x 4	50
HBCB	4 x 2 1/8	50
5BC	4 11/16 x 4 11/16	50
4RBC	4" round	50

Covers with various device applications also available.

*All items may be purchased individually.

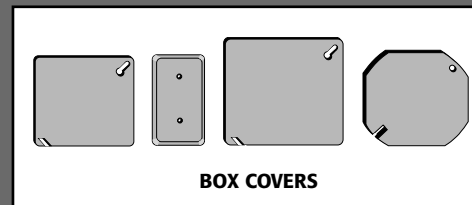

BOX COVERS

Questions? Answers at...

Western US: 866 CED-ELEV Eastern US: 866-253-2915
or 866-233-3538 • Fax 562-427-8429 or 860-256-2211 • Fax 860-290-8970

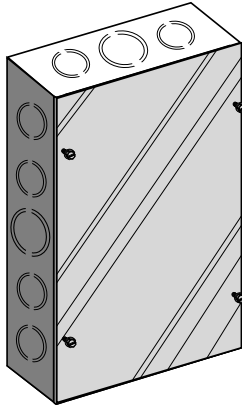
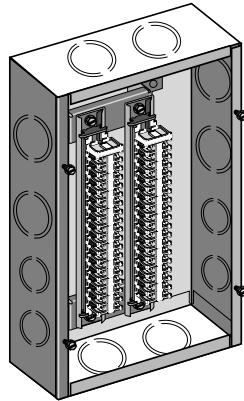
SCREW-COVER PULL BOX

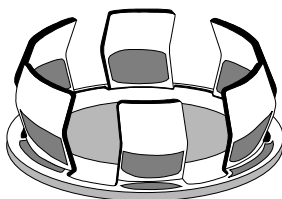
JUNCTION BOX WITH TERMINALS

**THREE PIECE
KNOCKOUT
PLUG**

METAL KNOCKOUT PLUG

Boxes & Covers

Screw-Cover Pull Boxes (with cover and knockouts) (UL listed)

Part Number	Size inches	Depth inches	Standard Packaging
444SC	4 x 4	4	1
664SC	6 x 6	4	1
6124SC	6 x 12	4	1
884SC	8 x 8	4	1
10104SC	10 x 10	4	1
12124SC	12 x 12	4	1
18184SC	18 x 18	4	1
2464SC	24 x 6	4	1
24244SC	24 x 24	4	1
886SC	8 x 8	6	1

6" depth boxes also available.

NEMA 4 Enclosures also available

Junction Boxes (with knockouts and terminals)

Part Number	Size inches	Depth & Capacity inches • wire count	Standard Packaging
JBX40	14 x 8½	3¼ • 40 wires	1
JBX80	24 x 8½	3¼ • 80 wires	1
JBX108	36 x 8½	3¼ • 108 wires	1

Junction Box Components

Part Number	Description	Standard Packaging*
6G38TSDIN	Terminal block	25
6G38EDIN	Terminal block end	25
3F	DIN rail	6' 6" lengths
220SP	20 Position 300V double row terminal block	

Three Piece Knockout Plugs

Part Number	Size inches	Standard Packaging*
D10S	½	100
D20S	¾	50
D30S	1	25
D40S	1¼	25
D50S	1½	10
D60S	2	10
D70S	2½	10
D80S	3	10

*All items may be purchased individually.

Metal Knockout Plugs

Part Number	Size inches	Standard Packaging*
S50	½	100
S75	¾	100
S100	1	50
S125	1¼	50
S150	1½	50
S200	2	25

*All items may be purchased individually.

Questions? Answers at...

Western US: 866 CED-ELEV Eastern US: 866-253-2915
 or 866-233-3538 • Fax 562-427-8429 or 860-256-2211 • Fax 860-290-8970

Miscellaneous Hardware

Mechanical Lugs

Part Number	Size	Standard Packaging*
CB35-36-CY	#14-6awg	100
CB70-14-CY	#8-2awg	100
CB125-14-QY	#2-1/0	25
CB175-38-QY	#4-3/0	25
CB225-56-QY	#2-4/0	10

The above mechanical lugs and split bolt connectors referenced are for the most common cable sizes used. Many more sizes are used and are available from our stock. Please ask your sales representative for details.

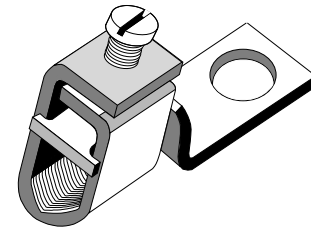

ILSCO MECHANICAL LUGS

Compression Lugs

Part Number	Wire Size	Hole Size	Standard Packaging*
LCAS2/0-38	2/0awg	3/8"	10
LCAS1-14-E	1awg	1/4"	20
LCA2-14-Q	2awg	1/4"	25
LCAS4-38-L	4awg	3/8"	50
LCA6-14-L	6awg	1/4"	50
LCA6-38-L	6awg	3/8"	50
LCA8-14-L	8awg	1/4"	50

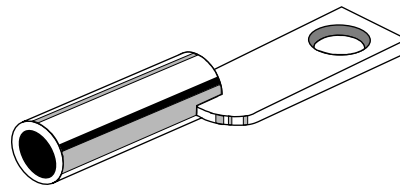

COMPRESSION LUG

Split-bolt Connectors

Part Number	Size	Standard Packaging*
SBC2-C	T&2-6 STR	100
SBC3-C	4 STR	100
SBC4S-C	4-8 STR	100
SBC6S-C	6-8 STR	100
SBC8-C	16-8 STR	100

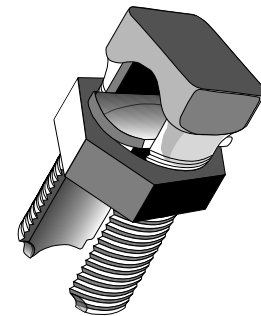

SPLIT-BOLT CONNECTOR

Tabs, Forks & Rings

Part Number	Size	Type	Standard Packaging
MNG1810R/LX	22-18awg	10 ring	100
MNG1810FBX	22-18awg	10 fork	100
MNG1410RX	16-14awg	10 ring	100
MNG1410FBX	16-14awg	10 fork	100
MNG1410FLX	16-14awg	10 lock fork	100
MNG1010RX	12-10awg	10 ring	50
MNG1010FXB	12-10awg	10 fork	50

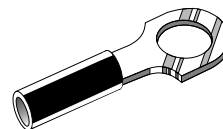

RING

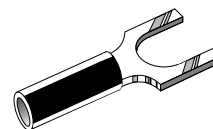

FORK

Many different sizes of rings and forks are stocked. To order, insert desired size into the above part numbers where the "10" appears after the dash. (i.e.: for a 16-14awg 8 ring, you would order part number RB14-8.)

*All items may be purchased individually.

Polaris Connectors

Part Number	Size	Standard Packaging
PCSB2/0-2-12	1/0-14 AWG	6
PCSB250-2S-6Y	250 MCM-6 AWG	6
PCSB250-2S-6Y	3/0-6 AWG	6
PCSB4-2S-12Y	4-14 AWG	12
PCSB2/0-2-12	1/0-14 AWG OFFSET	6



POLARIS CONNECTOR

Questions? Answers at...

Western US: 866 CED-ELEV Eastern US: 866-253-2915
or 866-233-3538 • Fax 562-427-8429 or 860-256-2211 • Fax 860-290-8970

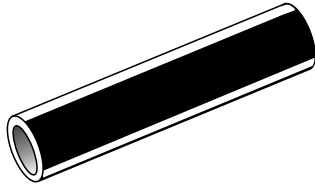

INSULATED BUTT SPLICE

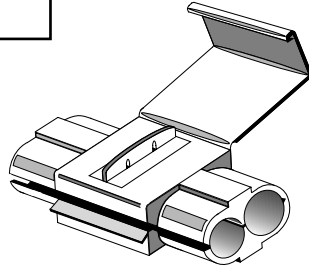

SCOTCHLOK PIGTAIL

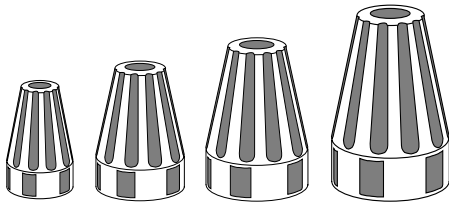

WIRE NUTS

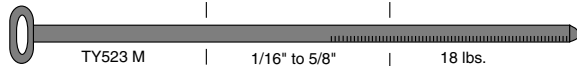

TY523 M | 1/16" to 5/8" | 18 lbs.

TY-RAP

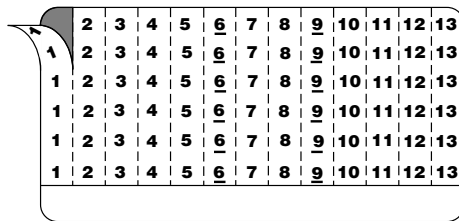

WIRE MARKER BOOKS

Miscellaneous Hardware

Insulated Butt Splices (UL listed, CSA Certified)

Part Number	Size	Standard Packaging
MN18BCX	22-18awg	100
MN14BCX	16-14awg	100
MN10BCX	12-10awg	50

ScotchLok® Components (UL listed, CSA Certified)

Part Number	Size	Standard Packaging
557 (red)	22-16awg	100
558 (red)	22-16awg	100
560 (blue)	18-14awg	100
562 (yellow)	12-10awg	100

Wire Nuts (UL listed, CSA Certified)

Part Number	Size	Color	Standard Packaging
30071	22-16awg	gray	100
30072	22-14awg	blue	100
30073	22-14awg	orange	100
30074	18-10awg	yellow	100
30076	18-10awg	red	100

Wing nuts also available.

Ty-Raps (UL listed)

Part Number	Length inches	Standard Packaging
CT4NT18C	3.62	100
CT6NT40C	5.50	100
CT8NT50C	7.31	100
CT11NT50C	11.08	100
CT15NT120C	13.38	50
CT36NT175L	30.00	50

For weatherproof add "X" to end of part number.

Wire Marker Cards & Dispensers

Part Number	Description
PCMB-1	Wire marker book # 0-9
PCMB-14	Wire marker book # 46-90
PCMB-2	Wire marker book A-Z
PCMB-3	Wire marker book 1-45

Number dispenser refills available.

Questions? Answers at...

Channel & Components Screws, Fasteners, Cush Clamps

Channel & Components (UL listed)

Part Number	Size	Type	Standard Packaging*
W500H	1 1/2" x 3/4" x 10'	B907 14-gauge channel/holes one side	600'
W200H	1 1/2" x 1 1/2" x 10'	B905 12-gauge channel/holes one side	600'
W24EG	1/4"	B910 spring nut for all channel	100
B26EG	3/8"	B910 spring nut for all channel	100
W28EG	1/2"	B910 spring nut for all channel	100
W6026AEG	1/2"	C106 EMT strap for 1 1/2" and 3/4" channel	100
W6028AEG	3/4"	C106 EMT strap for 1 1/2" and 3/4" channel	100
W6030AEG	1"	C106 EMT strap for 1 1/2" and 3/4" channel	100
W6032AEG	1 1/4"	C106 EMT strap for 1 1/2" and 3/4" channel	100
W6034AEG	1 1/2"	C106 EMT strap for 1 1/2" and 3/4" channel	100
W6038AEG	2"	C106 EMT strap for 1 1/2" and 3/4" channel	50

Channel also available with holes, plain, green and galvanized.

Screws, Fasteners & Accessories

Part Number	Size	Type	Standard Packaging*
W7124EG	3/8" x 10'	Threaded rod	10'
RC2-1/2	1/2"	Threaded couplings	100
RC2-3/8	3/8"	Threaded couplings	100
RC2-5/8	5/8"	Threaded couplings	100
DA38	3/8"	Lead anchors	100
FW38	3/8"	Flat washers	100
LW38	3/8"	Lock washers	100
HN38	3/8"	Hex nuts	100
RMC1434	1/4" x 3/4"	Round-head nuts and screws	100
RMC141	1/4" x 1"	Round-head nuts and screws	100
RMC14114	1/4" x 1 1/4"	Round-head nuts and screws	100
RMC14112	1/4" x 1 1/2"	Round-head nuts and screws	100
RMC142	1/4" x 2"	Round-head nuts and screws	100
ZA150	1/4" x 1"	Nail-ins	100
DA14	1/4"	Lead anchors	100
FW14	1/4"	Flat washers	100
LW14	1/4"	Lock washers	100
HN14	1/4"	Hex nuts	100
TB44	1/4" x 3"	Toggle bolts	100
MB141	1/4" x 1"	Hex-head bolt	100

*Other sizes available for all hardware & threaded rod

Cush Clamps

Part Number	Nominal Pipe Size	O.D. Size
200050	1/2"	.840
200075	3/4"	1.050
200100	1"	1.315
200125	1 1/4"	1.660
200150	1 1/2"	1.900
200200	2"	2.375
200250	2 1/2"	2.875
200300	3"	3.500
200350	3 1/2"	4.000
200400	4"	4.500

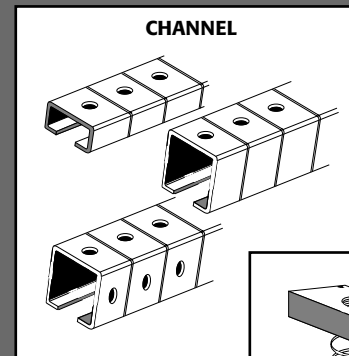
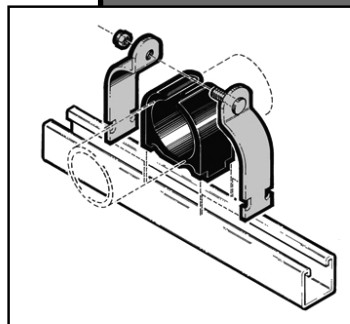

CHANNEL

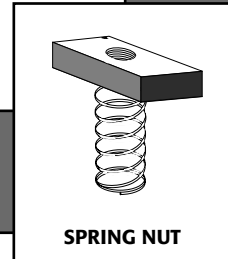

SPRING NUT

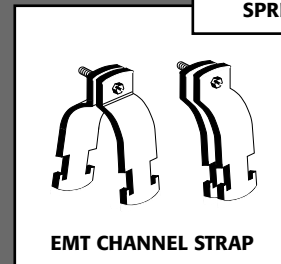

EMT CHANNEL STRAP

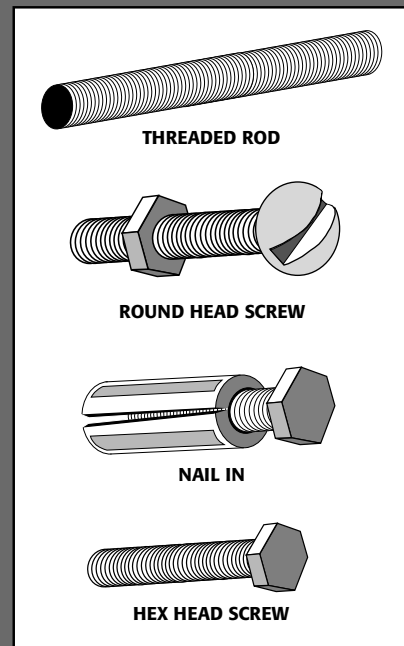

THREADED ROD

ROUND HEAD SCREW

NAIL IN

HEX HEAD SCREW

ELECTRICAL & INDUSTRIAL PRODUCTS

Questions? Answers at...

Western US: 866 CED-ELEV Eastern US: 866-253-2915
or 866-233-3538 • Fax 562-427-8429 or 860-256-2211 • Fax 860-290-8970

FANS, COOLERS & HEATERS

6

In this Section

"SEF-E" 2-Speed Propeller Fan	6.2
"SOE" Dust and Moisture-Proof Blower Wheel Fan	6.2
"AA" 3-Speed Blower Wheel Fan	6.2
One and Two-Speed Fans	6.3
Two-Speed Exhaust Fans	6.3
Fan Replacement Parts.	6.3
Emergency Power Supply	6.3
Grills.	6.4
Lighted Grills	6.4
Heater for Elevator Cab	6.4
Tank Heaters	6.4
SEIM Tank Cooler	6.5
Oil-to-Air Heat Exchanger with pump-motor and electric fan	6.5
Hydrastar Oil Cooler.	6.6



Exhaust Fans 2 and 3-Speed

Model "SEF-E" 2-Speed Propeller Fan

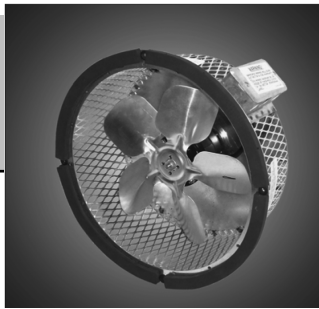

WIRING DIAGRAM

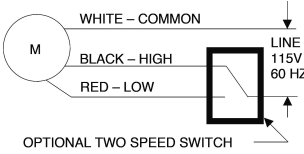

Part Number	HP	RPM	FLA	Volts	Phase	Cycle	Cap.	Speeds
06-02019	16.4 Watt	1450	.77	115	Single	60	None	2

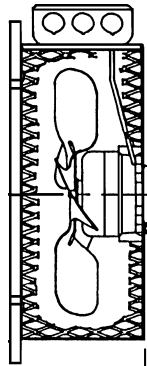

MOUNTING TEMPLATE

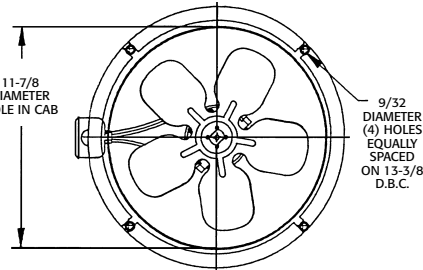

Component Specifications

Style
Exhaust
Pressure configuration by special order only

Maximum CFM
350

Features
Smallest and least expensive

Model "SOE" Dust and Moisture-Proof Blower Wheel Fan



WIRING DIAGRAM

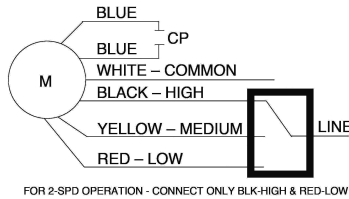

Part Number	HP	RPM	FLA	Volts	Phase	Cycle	Cap.	Speeds
06-01068	1/33	1050	.84	115	Single	60	None	3

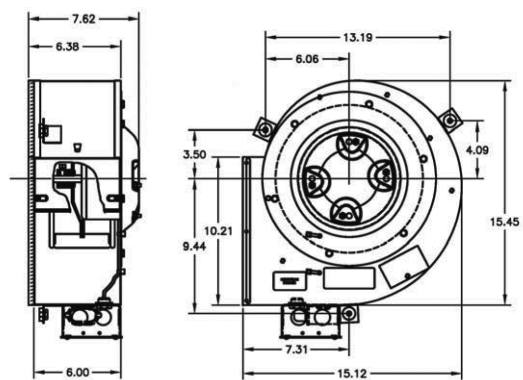

Component Specifications

Style
Exhaust configuration
Dust, moisture and explosion-proof models available

Maximum CFM
480

Features
Most commonly used

Repair Kit
#06-01066

Model "AA" 3-Speed Blower Wheel Fan



WIRING DIAGRAM

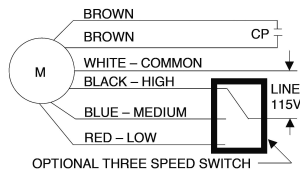

Part Number	HP	RPM	FLA	Volts	Phase	Cycle	Cap.	Speeds
06-01058	1/12	825	1.9	115	Single	60	5 MFD, 370V	3

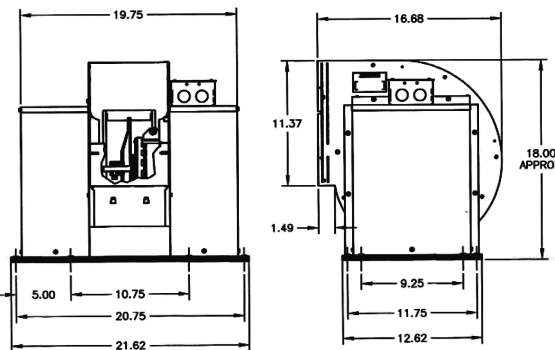

Component Specifications

Style
Exhaust configuration
Dust, moisture and explosion-proof models available

Maximum CFM
510

Features
Double air inlet for quietest operation

Repair Kit
#96-13502

Questions? Answers at...
(866) CED-ELEV • (866) 233-3538
www.cedlevator.com

Blower and Exhaust Fans

One & Two-Speed Fans

Engineered for maximum air distribution, our fans are totally enclosed, prelubricated, and easy to install. The 12" x 12" x 4 1/4" 16-gauge steel cage houses a low rpm motor with five blade fan that is both quiet and dependable.

Part Number	CFM	Volts	Height	Speeds
SSF3C	380	115V AC	4 1/4"	1
SSFE	325	220VAC, 50-60 HZ	4 1/4"	1
SSF3R	380	115V AC	4 1/2"	1
TSF1	345-300	115V AC	4 1/4"	2
TSFE	325-290	220VAC, 50-60 HZ	4 1/4"	2
TSF1C	345-300	115VAC	4 1/4"	2

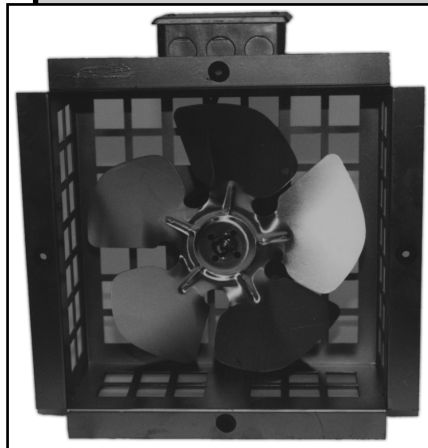

SSF3, TSF1

Two-Speed Exhaust Fans

12" diameter, welded steel housing.

Part Number	Maximum CFM	Volts	Height	Speeds
TSFE1420	375	115V AC	4 1/2"	2
TSFE1424	375	115V AC	3 1/2"	2



TSFE1420

Fan Replacement Parts

Part Number	Description
21FN001	Single-speed fan motor
21FN002	Two-speed fan motor
A01FN001	Two-speed suction blade
A01FN002	Single-speed suction blade
A01FN003	Single-speed push blade

Model OE 3 Speed Blower

Part Number	Description
06-01064	1/12 hp, 1050 rpm, 3.0 FLA, 115 V, single phase, 60 cycle, 3 Speeds



06-01064

Questions? Answers at...
 (866) CED-ELEV • (866) 233-3538
www.cedelevator.com



ADG-12S

ADGE145SFL

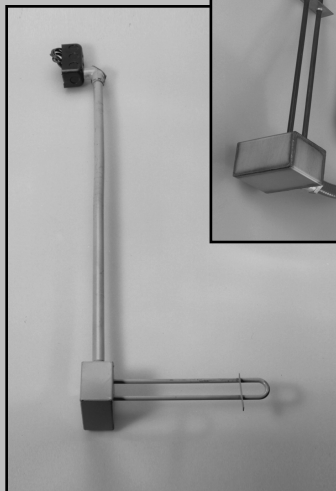
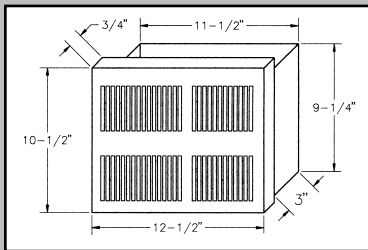

TH120

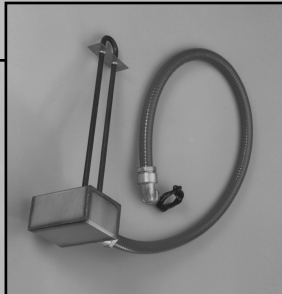

TH120F

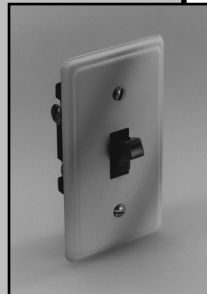

THO

TANK HEATER WORKSHEET

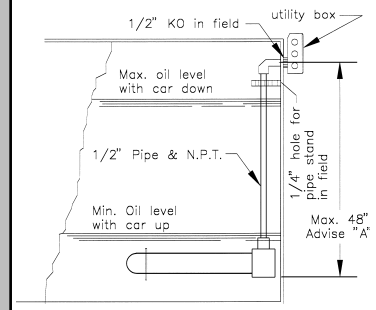

Grills, Heater & Tank Heaters

Grills

Part Number	Diameter (inches)	Finish
ADG-10	10	white
ADG-12	12	white
ADG-16	16	white

Lighted Grills

Combination glare-free fluorescent light and air distribution grille. One 40 watt circle line lamp. Durable plexiglass light diffuser. Mounts independent of fan.

Part Number	Finish
ADGE145SFL	Stainless
ADGE145BFL	Bronze
ADG-FL-CVR	(Replacement Fluorescent Cover)
ADGE145SI*	Stainless
ADGE145BI*	Bronze

* Incandescent lighting—four 40 watt lamps

Heater for Elevator Cab

Ceiling mounted fan forced heater is ideal for parking garages and other area installations

Part Number **QCH-1151**

- Navajo white steel faceplate
- Lightweight, 8 lbs.
- 1500 watts (5120 BTU/hour)
- 120 VAC power, 12.4 amps
- Remote thermostat
- Thermal cutout to prevent overheating

Tank Heaters

The integral thermostat is set for 100° F, has 275W, 120V, and 60Hz, in stock. Permanently mounted so that turbulence will not move heater in tank. Custom made for your specific applications

(Note: "A" Dimension must not exceed 48" maximum. See worksheet for installation specs and size requirements.)

Part Number	Description
TH120	
TH120F	(Same as TH120 with standard 40" flex cord)
THO	(20 amp red on/off switch with cover)

Tank Heater Worksheet

Recommended Installation:

1. If possible, locate heater at bottom of tank, or with minimum of 4" of oil cover.
2. Make all knock-outs and holes above high oil mark in tank.
3. Mount standard switch and cover in utility box if required for summer-winter operation (not furnished, optional).

Questions? Answers at...
 (866) CED-ELEV • (866) 233-3538
 www.cedlevator.com

Tank Coolers

Oil Cooler

The Oil Cooler can be mounted to the power unit or located in a remote location. When the oil temperature in the reservoir reaches a preset limit, it is circulated through the radiator. This process reduces the oil temperature by nearly 40°F depending on site conditions. The oil is also filtered as it runs through the system, which results in enhanced performance and extended component life. The filter head has a sight gauge to indicate when the filter needs to be changed.

Technical data:

- 3/4 HP, 115 VAC, 1 phase, 7.2 FLA pump motor or 208-230 VAC, 1 phase, 3.6 FLA pump motor
- 1/4 HP, 115VAC, 1 phase, 3.6 FLA 1900 CFM fan motor or 208-230 VAC, 1 phase, 1.4 FLA 1900 CFM fan motor
- Heat removal: 17,500 BTU/hr @ 40°F temp delta
- 8 GPM, 75 PSI cast iron pump
- Weighs approximately 140 lbs
- Adjustable thermostat control
- 80db at 3 ft.
- Electrical requirement, 115 VAC, 1 phase, 20amp separate circuit
- 10 micron filter in hydraulic oil line
- Filter head with sight gauge to indicate when the filter needs to be changed
- Heavy gauge frame construction
- Includes all fittings and hardware needed for adjacent-mount installation
- Includes instructions for installation

Part Number **10248**

Replacement Filter Part Number **1953**

Oil-to-Air Heat Exchanger with pump-motor and electric fan

- Stabilizes the oil temperature
- Operates in the bypass flow independent of the power unit
- Controlled by adjustable thermostat in power unit
- Located next to power unit
- Adjustable thermostat and wall mounting brackets included

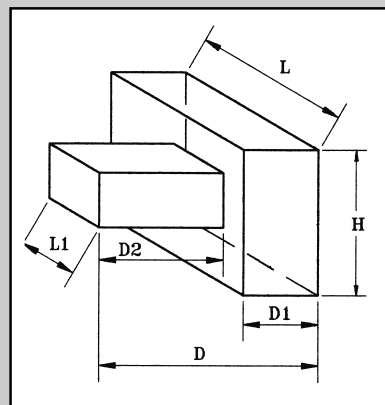

Part Number	Voltage	Motor	Cooling Capacity	Weight
BUCR2S	220/460V	½ HP	12,100 BTU/hr	145 lbs
BUCR3S	220/460V	2 HP	29,000 BTU/hr	165 lbs
BUCR4S	220/460V	2 HP	47,800 BTU/hr	180 lbs

Dimensions

Part Number	D1	D2	D	H	L1	L
BUCR2S	7"	13"	20"	15"	8"	15"
BUCR3S	9"	16"	25"	18"	8"	17"
BUCR4S	12"	17"	29"	21"	11"	19"

Available Options

- Controller (starter, circuit breaker, fuses and terminal blocks)
- Flexible hoses
- Replacement motors: **BUCR2SM** & **BUCR4SM**

Questions? Answers at...
 (866) CED-ELEV • (866) 233-3538
www.cedlevator.com

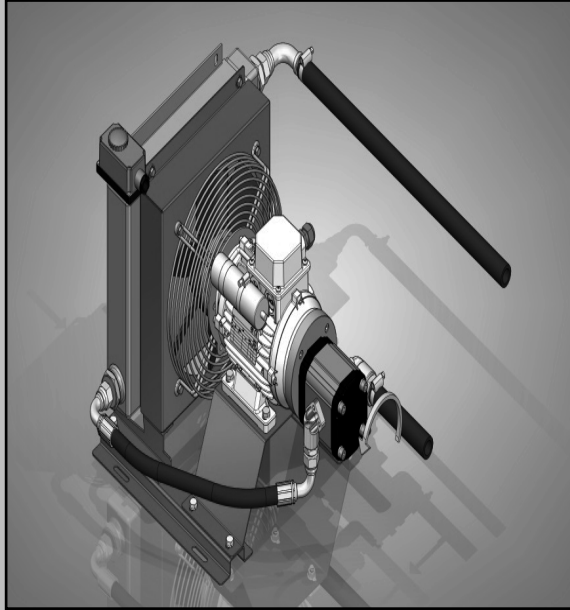

Hydrastar Quiet Cool Oil Coolers

HYDRASTAR QUIET COOL OIL COOLERS

Technical data:

UL/CSA listed
 21,000 BTU cooling capacity @ 40 F Temp Delta (6KW)
 Extremely low noise (pump is 55 dBa @ 3 ft)
 115/230 vac operation
 Manually adjustable thermostat
 Complete with hose kit (9.5 ft x 2)
 Lightest weight in the industry – 67 lbs

Oil Cooler Part Number **62000568606**
 Filter Kit Part Number **620005686040**

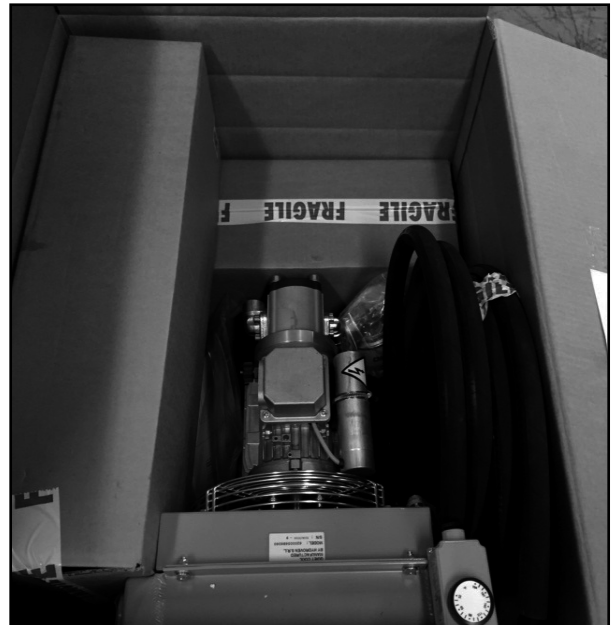

CONTROLLERS, FIXTURES, DOORS, EDGES & PUMP UNITS

7

In this Section

Controllers.....	7.2-7.3
Car Stations.....	7.4
Hall Stations & Lanterns.....	7.5-7.6
Doors.....	7.7-7.8
Edges (IR Curtain Units).....	7.9-7.10
Pump Units.....	7.11

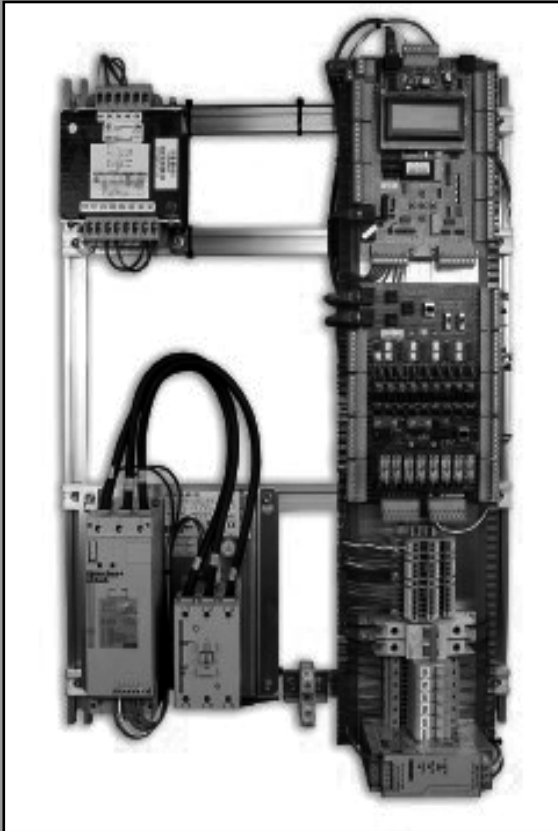

Elevator Controllers

Stocked and readily available at all CED locations are Smartrise Hydraulic controllers—designed for performance, safety, durability, and the quality that CED is known for nationally. CED has partnered with Smartrise to supply an off-the shelf elevator controller to meet the needs of the elevator industry. CED understands your needs and realizes that having critical elevator equipment is vital to returning cars to service.

Package Includes:

- Prebuilt 2-board (MR/COP) Hydraulic System
- Sprecher + Schuh soft starter
- SmartPositioning
- On-Board Diagnostics (no tools required)
- Non-Proprietary Software
- Pre-programmed Job Specific Requirements
- Job Binder with Prints and Installation Manual
- Code Required Independent & Hoistway Access
- Compatible with most hydraulic operations and manufacturers

SPECIFICATIONS

APPLICATION Hydraulic

FEEDBACK Distance and Velocity

DISPATCH Up to an 8 Car Group

MAX OPENINGS 10 F/R

MAX SPEED 200 FPM

DIMENSIONS 30" H x 24" W x 10" D

CABINET NEMA 1

AMP RANGE 51-147 AMPS

Optional Accessories:

- Interface to Load-Weighing Device
- Car Top Inspection Station
- External Emergency-Rescue Device (Battery Lowering)
- Programming Pod
- Interface to Voice Annunciator
- Card Reader Access
- Group Operation

Questions? Answers at...

(866) CED-ELEV • (866) 233-3538
www.cedlevator.com

Buying A Controller Package

STEPS FOR BUYING A CONTROLLER PACKAGE

- 1) Fill out a CED Specific Engineering Data Form (EDF) and return to CED (Available online)
- 2) Purchase the controller from CED – who will then turn in paperwork to Smartrise for engineering review (Review typically takes 24 hours)
- 3) Upon Smartrise approval for the job specific requirements, CED will be notified to release the controller to the customer. The controller can be picked up at Will Call or Shipped.
- 4) Smartrise creates the Job Binder and ships directly to the customer. This will include:-Job specific drawings-Job specific software (on a 256 MB Flash Drive)-IO sheet(s) for SRU Board I/O's-Equipment Installation Manual
- 5) Customer installs the job specific software on the packaged controller.

OPTIONAL ACCESSORIES INCLUDE:

SMARTCONNECT

SmartConnect is Smartrise's Inspection Box located on the car top. It comes pre-wired which allows for ease of installation via a Cat-5 cable. The box has pre-drilled mounting brackets with an incandescent light bulb socket. SmartConnect seamlessly integrates with Smartrise Hydraulic controllers.

GROUP CONTROLLER

The Group Controller is an SRU programmed as a dispatch board for two (2) Cars. The board is mounted in a separate cabinet and contains a DIN rail for power and car communication wiring.

BATTERY LOWERING

The Reynolds and Reynolds Powervator Emergency Return System can be integrated with Stocked Controller. The Powervator is a battery operated inverter in a fully enclosed case that provides flexibility for improved controller layout and accessibility. Available in 208 VAC or 240 VAC

Optional Can & Battery lowering Switch sold separately



Questions? Answers at...
(866) CED-ELEV • (866) 233-3538
www.cedelevator.com

6 STOP CAR OPERATING PANEL

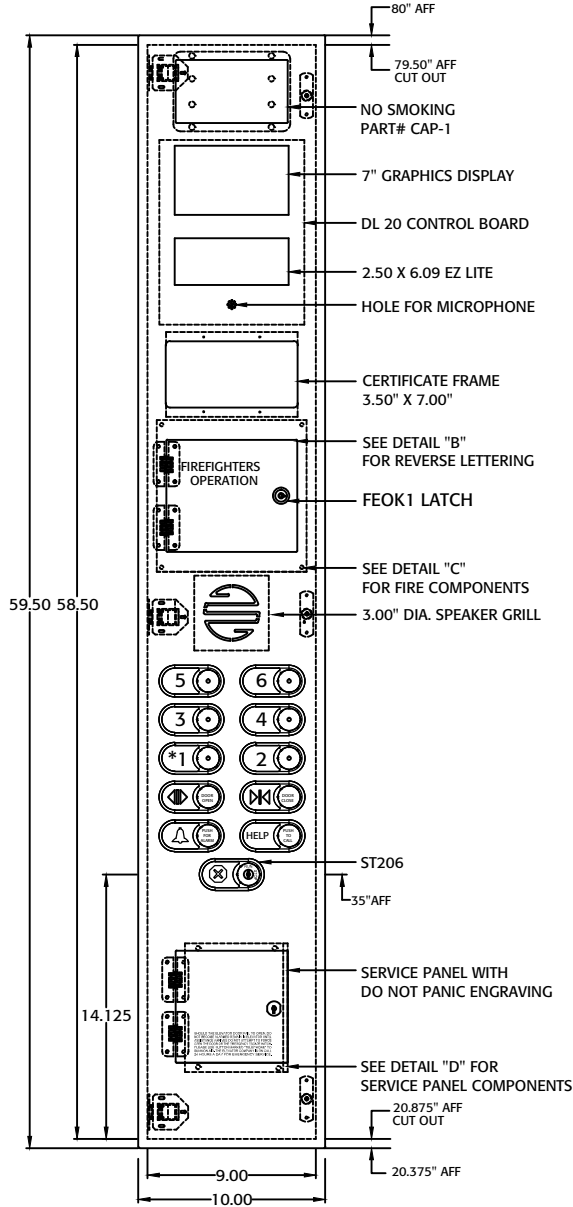

Part Number	Description
2 STOP LH/RH	ECC 2 STOP DL20 COP
3 STOP LH/RH	ECC 3 STOP DL20 COP
4 STOP LH/RH	ECC 4 STOP DL20 COP
5 STOP LH/RH	ECC 5 STOP DL20 COP
6 STOP LH/RH	ECC 6 STOP DL20 COP

Car Station Units

CAR STATION NOTES:

FACEPLATE: #11 GA. STAINLESS STEEL W/#4 BRUSH FINISH

LAMP VOLTAGE: MULTI-VOLT

SPEAKER GRILL: ECC DL 20 - 7"

HINGED SIDE: LEFT

FASTENERS: TWIST PANEL LOCKS

PUSH BUTTONS:

CAL-VR-MV-SS VANDAL RESISTANT ROUND BUTTON: DIAMETER 1.38" ILLUMINATING COLLAR WITH BLUE LED FOR FLOOR, DOOR BUTTONS AND RED LEDS FOR "PUSH TO CALL" AND "PUSH FOR ALARM" AND INTEGRATED SURROUND WITH FLUSH MOUNTED CALIFORNIA RAISED BRAILLE, (DIAMETER 1.38" RAISED WHITE CHARACTERS ON BLACK BACKGROUND)

STOP SWITCHES: (ECC-STOP) ECC KEY SWITCH/ RED W/ WHITE CHARACTERS ALONG W/ ECC FISHTAIL BRAILLE

ENGRAVED GRAPHICS:

- "NO SMOKING" 7.5" BLK
- "CAPACITY ___ LBS." 2.5" BLK.
- "FIREFIGHTERS OPERATION" 1.25" RED
- "PUSH TO CALL" 2.5" BLK.
- "DO NOT PANIC..." 1.25" BLK

IN BOX COMPONENTS:

DL 20 - 7" BOARD

FIRE PANEL SUB-PLATE

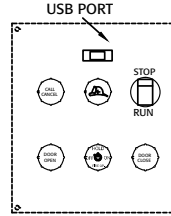

DETAIL "C"

SERVICE PANEL SUB-PLATE

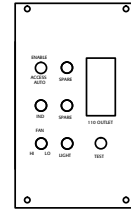

DETAIL "D"

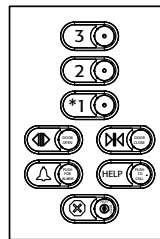

3 STOP

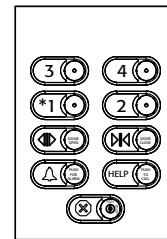

4 STOP

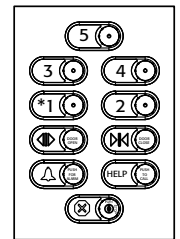

5 STOP

The DL-20 is a multi-featured device that integrates with Smart Rise, Motion Control, & Elevator Controls serial link products. The DL-20 comes standard with a high resolution 7" Display that performs the functions of the Position Indicator, Fire Service Light, System Status Indicator, and a client use area that is fully customizable for advertising or announcements. The DL-20 communicates with the serial controller to display the various messages in the form of customizable pictures & Icons as well as providing voice announcement in any language for the visually impaired. Its integrated, advanced feature Emergency Phone can consolidate up to 8 Elevator Phones on a single phone line. The DL-20 also includes an intensity adjustable LED Emergency light with long life battery and charging circuit. Additionally, the DL-20 acts as a remote access and monitoring device using just the existing elevator phone line. It allows the elevator company to call in and check the current status and what faults have occurred. It can also be programmed to call out to self-report various faults.

STOCKED HALL STATIONS & CAR LANTERNS

HALL STATIONS

ALL MODELS ARE INSTALLED WITH, OTHERWISE NOTED FACEPLATE:

FLUSH MOUNT: #11 GAUGE STAINLESS STEEL, #4 BRUSH FINISH

SURFACE MOUNT: #14 GAUGE STAINLESS STEEL, #4 BRUSH FINISH

LAMP VOLTAGE: 24V LED

FASTENERS: TAMPERPROOF SCREWS

TERMINAL HALL STATION

PART NUMBER: TH - FLUSH/SURFACE(F/S)

PUSHBUTTON: ECC - PUBC-01

DIMENSION: FACEPLATE: 5.00" X 19.00"
BOX: 3.875" X 17.25" X 3.50" DP

TERMINAL WITH ACCESS

PART NUMBER: THA - F/S

PUSHBUTTON: ECC - PUBC-01, ECC - CBC ALL WHITE

KEYSWITCHES: ECC DIA 1.393" ACCESS (ECC - INS205)

DISPLAY: EX 31/ EX 51 DISPLAY

DIMENSION: FACEPLATE: 5.00" X 19.00"
BOX: 3.875" X 17.25" X 3.50" DP

TERMINAL WITH ACCESS, FIRE SERVICE

PART NUMBER: THF - F/S

PUSHBUTTON: ECC - PUBC-01

KEYSWITCHES: ECC DIA 1.393" FIRE SERVICE

RESET/OFF/ON (ECC - FEOK1), ACCESS(ECC - INS205)

DIMENSION: FACEPLATE: 5.00" X 19.00"
BOX: 3.875" X 17.25" X 3.50" DP

INTERMEDIATE HALL STATION

PART NUMBER: IH - F/S

PUSHBUTTON: ECC - PUBC-01

DISPLAY: EX 31/ EX 51 DISPLAY

DIMENSION: FACEPLATE: 5.00" X 19.00"
BOX: 3.875" X 17.25" X 3.50" DP

INTERMEDIATE WITH FIRE SERVICE

PART NUMBER: IH - F/S

PUSHBUTTON: ECC - PUBC-01

KEYSWITCHES: ECC DIA 1.393" FIRE SERVICE

RESET/OFF/ON (ECC - FEOK1)

DISPLAY: EX 31/ EX 51 DISPLAY

DIMENSION: FACEPLATE: 5.00" X 19.00"
BOX: 3.875" X 17.25" X 3.50" DP

CAR RIDING LANTERN

FACEPLATE: #11 GAUGE STAINLESS STEEL, #4 BRUSH FINISH

LANTERN ARROWS:

2.50" X 2.50" WHITE LEXAN VANDAL RESISTANT PLASTIC
EXTENDED 1.88" FROM FACEPLATE

GREEN LED FOR UP ARROW, RED LED FOR DOWN ARROW

DISPLAY: EX 51 DIGITAL DISPLAY

LAMP VOLTAGE: MULTI-VOLT

FASTENERS: TAMPERPROOF SCREWS

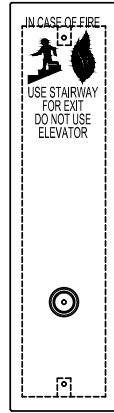

PART#
TH - FL

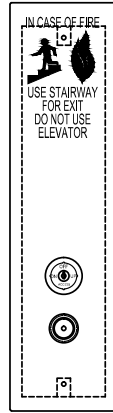

PART#
THA - FL

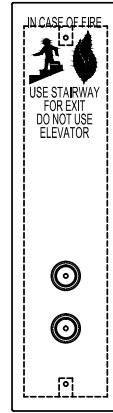

PART#
IH - FL

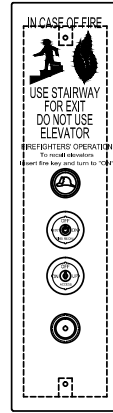

PART#
THAF - FL

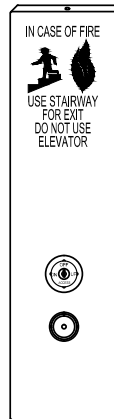

PART#
THA - S

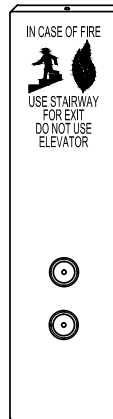

PART#
IH - S



PART#
THAF04 - S



PART#
INTF04 - S

CAR RIDING LANTERN

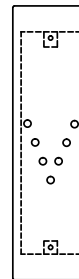
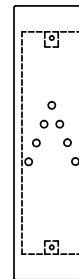
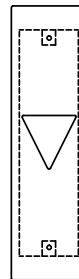
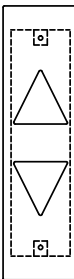
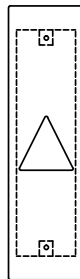

PART#
CRL

PART#
CRL - V

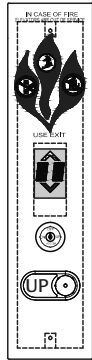

PART#
THA - FL - EX31



PART#
IHF - FL

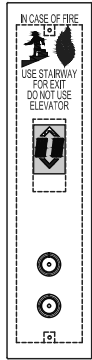

PART#
INT - FL - EX 31

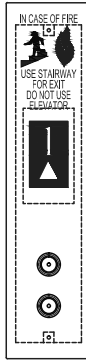

PART#
IH - FL - EX51



PART#
INTF - S - TRIF



PART#
THAF10 (S)

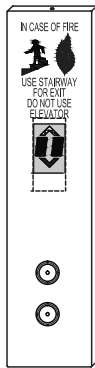

PART#
IH - S - EX 31

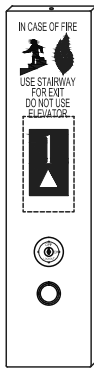

PART#
THA - S - EX 51

HALL PI



PART#
EX-51-AD - S



PART#
EX-51-AD - F

HALL PI WITH ARROWS



PART#
EX-51-ADA - S



PART#
EX-51-ADA - F

Custom Hall Stations & Car Lanterns

CUSTOM HALL STATIONS

FACEPLATE:

FLUSH MOUNT : #11 GAUGE STAINLESS STEEL, #4 BRUSH FINISH

SURFACE MOUNT : #14 GAUGE STAINLESS STEEL, #4 BRUSH FINISH

LAMP VOLTAGE : 24V LED

FASTENERS: TAMPERPROOF SCREWS

INTERMEDIATE HALL STATION - TRI FLAME

PART NUMBER: **IH - F/S**

PUSHBUTTON: ECC - PUBC-01

DISPLAY: EX 31/ EX 51 DISPLAY

DIMENSION: FACEPLATE: 5.00" X 21.00"
BOX: 3.875" X 19.25" X 3.50" DP

INTERMEDIATE WITH FIRE SERVICE - TRI FLAME

PART NUMBER: **IH - F/S**

PUSHBUTTON: ECC - PUBC-01

BRILLE: FISHTAIL BRILLE WITH WHITE CHARACTER AND BLACK BACKGROUND

KEYSWITCHES: ECC DIA 1.393" FIRE SERVICE RESET/OFF/ON (ECC - FEOK1)

DIMENSION: FACEPLATE: 5.00" X 21.00"
BOX: 3.875" X 19.25" X 3.50" DP

TERMINAL WITH ACCESS, FIRE SERVICE (2010 CODE)

PART NUMBER: **THAF - F/S**

PUSHBUTTON: ECC - PUBC-01, EMERGENCY PHONE

KEYSWITCHES: ECC DIA 1.393" FIRE SERVICE

RESET/OFF/ON (ECC - FEOK1), ACCESS(ECC - INS205)

DIMENSION: FACEPLATE: 5.00" X 21.00"
BOX: 3.875" X 19.25" X 3.50" DP

HALL PI

FACEPLATE:

FLUSH MOUNT: #11 GAUGE STAINLESS STEEL, #4 BRUSH FINISH

SURFACE MOUNT: #14 GAUGE STAINLESS STEEL, #4 BRUSH FINISH

LANTERN ARROWS:

2.50" X 2.50" WHITE LEXAN TRANSLUCENT PLASTIC EXTENDED 1.88" FROM FACEPLATE
GREEN LED FOR UP ARROW, RED LED FOR DOWN ARROW

DISPLAY: EX 51 DIGITAL DISPLAY

LAMP VOLTAGE: MULTI-VOLT

FASTENERS: TAMPERPROOF SCREWS

Questions? Answers at...

(866) CED-ELEV • (866) 233-3538
www.cedlevator.com



HOISTWAY AND CAR DOORS

CED offers genuine Columbia Elevator replacement 81 Style Hoistway and Car Doors. They are available as single-speed, center opening or two-speed side slide. All replacement doors include hardware, gibs, retainers and/or fire clips.* Center opening doors come with astragals. Doors are universal and can accommodate various types of equipment. And, our exclusive Replacement Door Program includes standard sized doors in baked prime or S/ST#4, in stock and available.

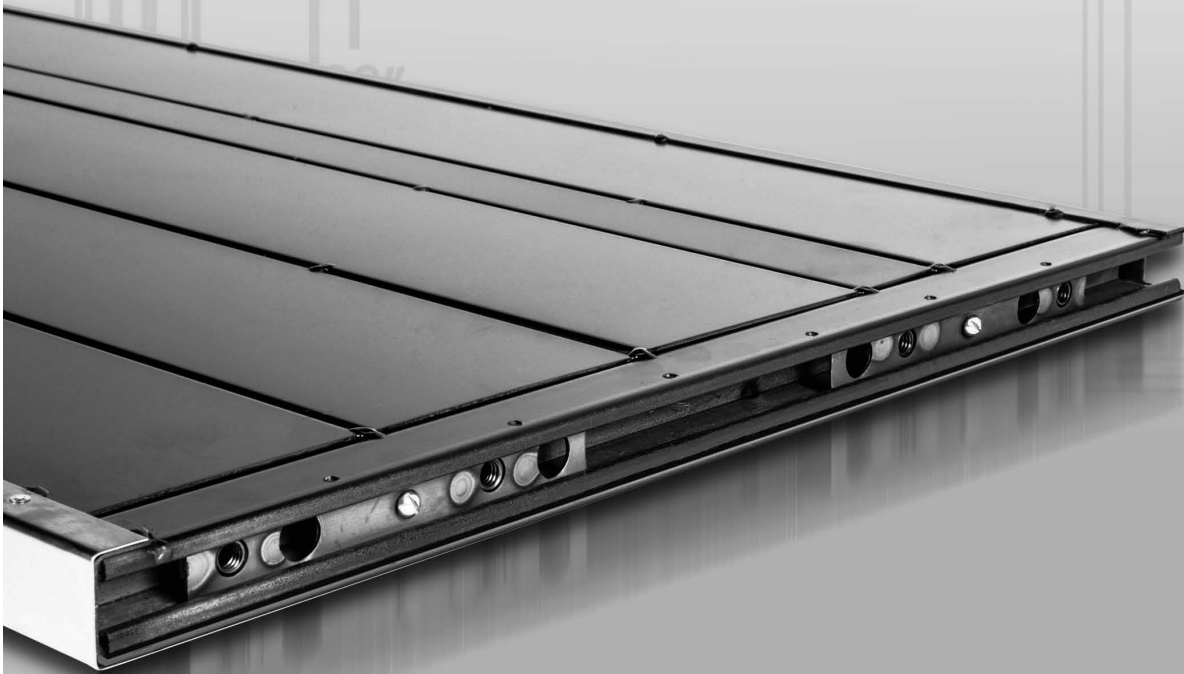

*Determined by door type and/or height.



HOISTWAY & CAR DOORS

Replacement Door Program

Need a replacement door fast? Standard sizes in S/ST#4 or Baked Prime are in stock and available. Doors are unhandled and undrilled.



81 Style

- Made out of cold rolled steel
- 16 gauge core for prime and baked enamel
- Wrapped for SS#4
- Reinforcement modules are the back of the door
- Unhanded doors
- 3/8" - 16 or 1/2" - 13 pendant bolts
- Universal top channel
- Unistrut design with slide-in plate and drilling for pendants



Two speed or Center opening - avail in S/ST#4 or Baked Prime

Size	Style	Catalog Number
42" x 84"	Baked Prime	HDTSP428416GABP
42" x 84"	S/ST#4 (20GA)	HDTSP428416GASS
48" x 84"	Baked Prime	HDTSP488416GABP
48" x 84"	S/ST#4 (20GA)	HDTSP488416GASS

Single speed -avail in S/ST#4 or Baked Prime

Size	Style	Catalog Number
36" x 84"	Baked Prime	HDSSP368416GABP
36" x 84"	S/ST#4 (20GA)	HDSSP368416GASS
42" x 84"	Baked Prime	HDSSP428416GABP
42" x 84"	S/ST#4 (20GA)	HDSSP428416GASS

Templates for GAL are provided for all hatch and car doors, making field installation simple and smooth

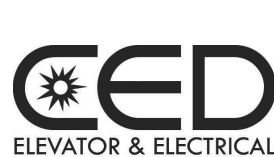
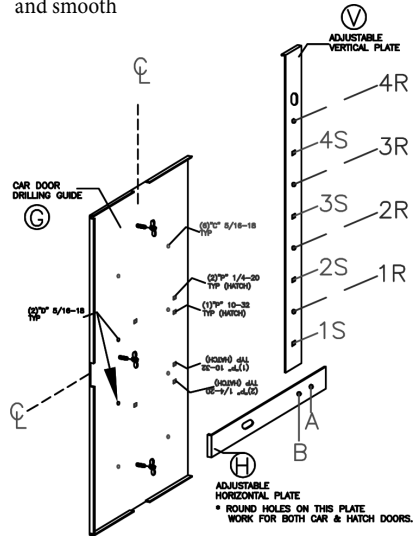

CEDES CEGARD/MAX-NT Infrared Curtain Unit

The only IR curtain with Phase I/Phase II Fire Recall Service... and it comes with nudging built in!

Built-in nudging

Replaces separate nudging unit for easiest installation. Factory setting of 20 sec. can be reset from 1-60 sec. Nudging buzzer volume is also adjustable.

Plugs into 17-265VAC/VDC

CEDES CEGARD/MAX-NT is the only infrared curtain that can be connected to any operating voltage from 17-265VAC/VDC with no additional wiring or modifying! Just plug it in and let it work.

Up to 154 infrared detection beams.

Integrated diagnostic circuitry

An on-board microprocessor adjusts automatically to optical conditions within protected area. As conditions change (from dust, dirt, etc.), microprocessor resets every beam for best performance under prevailing conditions.

LED current-control system

An LED drive circuit constrains emitting current to lowest possible effective level. Result: reduced stress on LEDs help extend their life to millions of hours. This feature is unique to the GateKeeper product line.

No incidents reported

With more than 150,000 units in service, not a single incident report has been recorded. This is most meaningful to anyone who has been named in a liability suit due to an unreliable door protection system.

CSA approved, Fire-Code conformant

CEDES CEGARD/MAX-NT meets all ANSI requirements and other U.S. and Canadian performance standards. Also conforms to Phase I and Phase II Fire Codes.

Extra-wide 16-ft. operating range

Weary of measuring door openings and matching them to the right door unit? CEDES CEGARD/MAX-NT works with all of them. One model, one part number, one great protection device. Choose 7ft. or 10ft. model according to door height.

Moving cable tested to 20,000,000 cycles

Part Number	Description
106 700	7ft. CEDES CEGARD/MAX-NT unit w/ mounting kit; (doors up to 7ft. high)
111 628	10ft. CEDES CEGARD/MAX-NT unit w/ mounting kit; (doors 7 to 10 ft. high)
103 117	Control unit (power supply)
102 409	Receiver (with blue plug)
102 408	Transmitter (with white plug)
102 788	Receiver cable, 16ft. (blue plug)
102 787	Transmitter cable, 16ft. (white plug)
102 251	Vision shield, 7ft.

Built-in nudging helps keep elevators moving in environments where riders are likely to hold open the doors. Nudging time is adjustable from 1 to 60 seconds

Simple installation!

Ships complete and ready to install, with the least possible number of separate components to speed installation and limit on-site assembly decisions. CEDES CEGARD/MAX-NT's vandal-resistant features keep it working right, and out of harm's way.

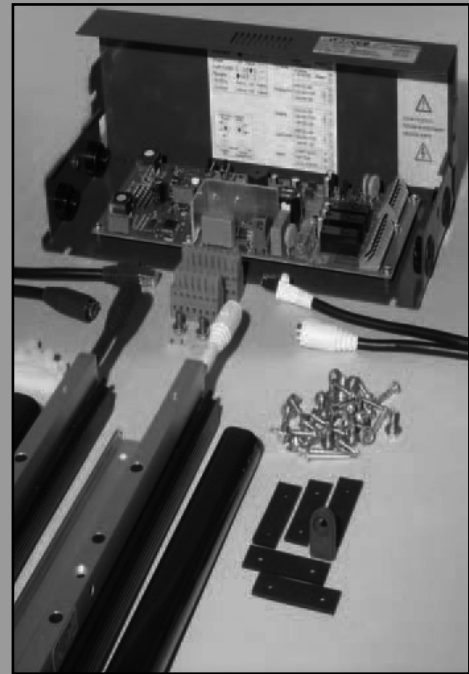

Technical Data

Supply voltage	17-265VAC/VDC; use Greenfield fittings for voltages >42V
Typical response time	90 ms
Max. response time	180 ms
Range	Up to 16ft. (5m)
Current	10VA at 115/230VAC, 200mA at 24VDC
Fuse	6.3A s/b (5 x 20mm)
Relay output (3)	AC max: 265VAC at 8.0A DC max: 125VDC at 0.5A or 24VDC at 8A DC min: 5VDC at 10.0mA (NOTE: If switching high voltage, use slave relay (not included))
Fire Recall I and II	Active: 17-265VAC/VDC Inactive: 0-5VAC/VDC
Protection height	71"
Door height	7 to 10ft.
No. of light beams	Up to 154 criss-cross beams
Light suppression	>100,000 lux
Connection plugs	WAGO 6 x 5.08
Cable length	16 ft. (5m)
Cable extension (avail)	10 ft. (3m)
Cable lifetime	20 million door movements (when installed correctly)
Enclosure rating, sensors	IP65
Enclosure rating, control unit	IP30
Vibration/shock	IEC 68-2-6 / IEC 68-2-29
Operating temp. range	-5° to +150°F (-20° to +65°C)
Storage temp. range	-20° to +220°F (-30° to +85°C)
EMC	IEC/EN 50081/50082-1, -2; EN 12015 and EN 12016 CSA B44.1/A17.5-1996
Mounting kit	Complete

Fire Recall Phase I & Phase II: life-saving protocols in an emergency

Fire Recall Phase I

If the input labeled "Fire Recall Phase I" is activated, the light curtain is disabled and nudging is enabled. The nudging buzzer sounds; it remains on during door close and until the car arrives at the designated landing. The buzzer remains on for 15 seconds after the "Fire Service Phase I" input is deactivated.

Fire Recall Phase II

If the input labeled "Fire Recall Phase II" is activated, the light curtain output is disabled. The nudging function works independent of "Fire Recall Phase II." Operation of the doors is taken over by emergency personnel. This eliminates the need for automatic re-opening and guards against false opening caused by smoke.

CONTROLLERS, FIXTURES, DOORS & EDGES

Questions? Answers at...
(866) CED-ELEV • (866) 233-3538
www.cedeelevator.com



Modular connecting cables lead the list of features that make CEDES CEGARD/MINI the easiest-to-install infrared curtain in the world.

CEDES CEGARD/MINI with UPS Technical Data

Supply voltage	17-240VAC/VDC; use Greenfield fittings for voltages >42V
Typical response time	90 ms
Range	Up to 16 ft. (5m)
Current	5VA at 115/240VAC 115mA at 24VDC
Relay output (3)	AC max: 265VAC at 8.0A DC max: 125VDC at 0.5A or 30VDC at 8A DC min: 5VDC at 10.0mA (NOTE: If switching high voltage, use slave relay (not included))
Protection height	71"
Door height	7 to 10 ft.
No. of light beams	Up to 154 criss-cross beams
Light suppression	>100,000 lux
Connection plugs	WAGO 6 x 5.08
Cable length	16 ft. (5m)
Cable extension (avail)	10 ft. (3m)
Cable lifetime	20 million door movements (if installed correctly)
Enclosure rating, sensors	IP65
Enclosure rating, control unit	IP54
Vibration/shock	IEC 68-2-6, -29
Operating temp. range	-5° to +150°F (-20° to +65°C)
Storage temp. range	-20° to +220°F (-30° to +85°C)
EMC	IEC/EN 50081/2, EN 12015/6
CSA	CSA B44.1/A17.5
Mounting kit	Complete

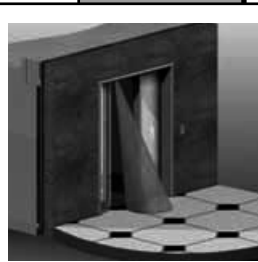

The IMS 100 sensor projects the invisible 'cone' of infrared light out onto the landing to detect people and objects approaching the elevator.

Part Number	Description
113 092	7-ft. CEGARD/MINI with UPS and mounting kit (drs up to 7ft. high)
113 167	10-ft. CEGARD/MINI with UPS and mounting kit (drs up to 10ft. high)
113 510	CEGARD/MINI with UPS waterproof kit for doors up to 7ft. high (For use with any GateKeeper or other existing 2-D light curtain. Includes intelligent distance and motion detection, intelligent "timeout" feature, automatic door fadeout.)
114 885	CEDES IMS 100 Sensor (includes flush mount and stainless steel surface mounting hardware.)

Edges

CEDES CEGARD/Mini with UPS & CEDES IMS 100 3D Sensor

CEDES is the industry choice for uncompromising door protection

Plugs into 17-240VAC/VDC

CEDES CEGARD/Mini with UPS and CEGARD/MAX-NT are the only infrared curtains that can be connected to any operating voltage from 17-240VAC/VDC with no additional wiring or modifying! Just plug it in and let it work.

Up to 154 infrared detection beams

Integrated diagnostic circuitry

LED current control system

No incidents reported

CSA approved

CEDES LIGHT CURTAINS meet all ANSI requirements and other U.S. and Canadian performance standards.

Extra-wide 12-16 ft. operating range

Moving cable tested to 20,000,000 cycles

CEDES IMS 100

Infrared Sensor System that easily retrofits with existing mechanical or electrical system

Easy to Install

Retrofits to ANY and ALL door protection systems without removing the existing system—even electromechanical safety-edge applications. Other 3D products require removal of the existing door safety edge in order to obtain 3D functionality.

Intelligent Design

Distinguishes between static and moving objects in the 3D zone. This allows the system to override the static object's presence, enabling the door to close, thus avoiding delays.

Adjustable 3D Zone

Adjusts to aim in two dimensions. For center-opening applications, the ideal detection zone is directly in front of the door. However, for side-

Replacement	
Parts	Description
102 975	Hardware Bag
102 750	Mounting Profile, 7ft.
103 600	Universal Power Supply (UPS)
111 892	Receiver (with blue plug)
111 893	Transmitter (with white plug)
104 033	Receiver cable, 16ft. (blue plug)
104 032	Transmitter cable, 16ft. (white plug)
102 973	Spacer Profile, 7ft.
102 751	Mounting Profile, 7ft.
102 995	Cable Guidewires
102 250	Vision shield, 7ft.

Questions? Answers at...
(866) CED-ELEV • (866) 233-3538
www.cedlevator.com

Pump Units

Now Stocking EJJE Pump Units, Complete with:

- Standard Electrical Boxes
- Oil Level Indicator
- Maxton Valve
- Settima Pump
- US Motor (Submersible or Dry)

Standard Units are capable of the following:

46 to 24 gallons of oil
10HP to 50 HP
230/460V and 200V
55 GPM to 220 GPM

Standard Sizes Available:

- 24"D x 38"W x 36"H
- 24"D x 42"W x 48"H
- 24"D x 44"W x 60" H

*Custom sizes available upon request



EJJE 
Elevator Manufacturing Inc.

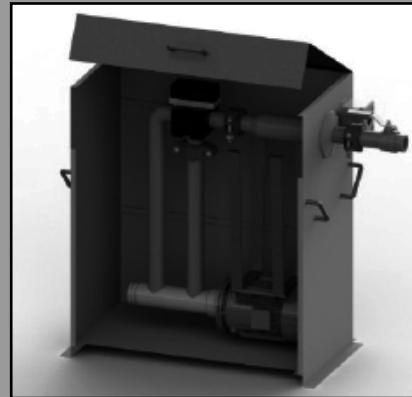

Questions? Answers at...
(866) CED-ELEV • (866) 233-3538
www.cedelevator.com

FUSES

8

Class CC Fuses	
ATDR Time-Delay	8.2
ATQR Time-Delay	8.2
ATMR Time-Delay	8.2
Midget Fuses	
ATM Fast-Acting	8.3
TRM Time-Delay	8.3
ATQ Time-Delay	8.3
OTM Fast-Acting	8.4
SBS Fast-Acting	8.4
Class RK5 Time-Delay Fuses	
TR Time-Delay	8.5
TRS Time-Delay	8.5
A6D(A)R Time-Delay	8.5
Electronic Fuses	
GAB Fast-Acting	8.6
GGC Fast-Acting	8.6
GDL Time-Delay	8.6
GGM Fast-Acting	8.7
GSC Time-Delay	8.7
GSD Fast-Acting	8.8
GDG Time-Delay	8.8
One-Time Fuses	
OTN Non-Limiting	8.9
OTS Non-Limiting	8.9
Semiconductor Fuses	
A30QS Series	8.10
A50QS Series	8.10
A70QS Series	8.10
Fuse Reference Table	8.11-8.12

Catalog Symbol

600 Volts AC

ATDR-1/2	ATDR-2 1/2	ATDR-7 1/2
ATDR-9/10	ATDR-2 9/10	ATDR-8
ATDR-9/10	ATDR-3	ATDR-9
ATDR-1	ATDR-3 1/10	ATDR-10
ATDR-1 1/8	ATDR-3 1/2	ATDR-12
ATDR-1 1/4	ATDR-4	ATDR-15
ATDR-1 4/10	ATDR-4 1/2	ATDR-20
ATDR-1 1/2	ATDR-5	ATDR-25
ATDR-1 9/10	ATDR-5 9/10	ATDR-30
ATDR-1 9/10	ATDR-6	
ATDR-2	ATDR-6 1/4	
ATDR-2 1/4	ATDR-7	

Catalog Symbol & Current Ratings

600 Volts AC

ATQR-1/4	ATQR-1 9/10	ATQR-7
ATQR-3/10	ATQR-1 9/10	ATQR-7 1/2
ATQR-4/10	ATQR-2	ATQR-8
ATQR-1/2	ATQR-2 1/4	ATQR-9
ATQR-9/10	ATQR-2 1/2	ATQR-10
ATQR-3/4	ATQR-2 9/10	ATQR-12
ATQR-9/10	ATQR-3	ATQR-15
ATQR-1	ATQR-3 2/10	ATQR-17 1/2
ATQR-1 1/8	ATQR-3 1/20	ATQR-20
ATQR-1 1/4	ATQR-4	ATQR-25
ATQR-1 3/10	ATQR-5	ATQR-30
ATQR-1 4/10	ATQR-6	—
ATQR-1 1/2	ATQR-6 1/4	—

Catalog Symbol & Current Ratings

600 Volts AC

ATMR-1/10	ATMR-1	ATMR-7
ATMR-1/8	ATMR-1 1/2	ATMR-8
ATMR-2/10	ATMR-2	ATMR-9
ATMR-1/4	ATMR-2 1/2	ATMR-10
ATMR-3/10	ATMR-3	ATMR-12
ATMR-4/10	ATMR-3 1/2	ATMR-15
ATMR-1/2	ATMR-4	ATMR-20
ATMR-9/10	ATMR-5	ATMR-25
ATMR-3/4	ATMR-6	ATMR-30



ATDR AMP-TRAP 2000®

**Time-Delay Current Limiting,
Class CC – Rejection Type**

Physical Size: 1 3/32" x 1 1/2" (10.3mm x 38.1mm)

Ampere Ratings: 1/4–30 Amps.

Voltage Rating: 600 Volts AC (or less), 300V DC

Interrupting Rating: 200,000A; 100,000A DC

Construction: Fiberglass Tube

Agency Information: Std. 248-4, Class CC

UL Listed, Guide JDDZ, File E4273

CSA Certified; Class 1422-02, File 53787



ATQR AMP-TRAP 2000®

**Time-Delay Branch Circuit Fuse
Class CC – Rejection Type**

Physical Size: 1 3/32" x 1 1/2" (10.3mm x 38.1mm)

Construction: Fiberglass Tube

Ampere Ratings: 1/10–30 Amps.

Voltage Rating: 600V AC, 300 DC

Interrupting Rating: 200,000A; 100,000A DC

Agency Information: Std. 248-4, Class CC

UL Listed, Guide JDDZ, File E3127

CSA Certified, Class 1422-01, File 012636



ATMR AMP-TRAP 2000®

**Fast Acting; Branch Circuit Fuse
Class CC – Rejection Feature**

Physical Size: 1 3/32" x 1 1/2" (10.3mm x 38.1mm)

Construction: Fiberglass Tube

Ampere Ratings: 1/10–30 Amps.

Voltage Rating: 600 Volts AC (or less).

Interrupting Rating: 200,000A; 100,000A DC

Agency Information: Std. 248-4, Class CC

UL Listed, Guide JDDZ, File E2137

CSA Certified, Class 1422-02, File 012636

Midget Fuses

ATM AMP-TRAP®

Fast Acting

Physical Size: 1³/₃₂" x 1¹/₂"
(10.3mm x 38.1mm)

Construction: Melamine Tube;
Nickel Plated Brass Endcaps

Voltage Rating:

ATM – 600V AC/600V DC
2³/₁₀-10A: 500V AC/DC,
12-30A: 500VAC/600VDC

Interrupting Rating:

100,000A
10,000A - RMS SYM. (UL)

Agency Information:

Std. 248-14
UL Listed, Guide JDYX, File E33925
CSA Certified, File 53787, Class 1422-01, HRC-Misc



ATM Catalog Symbol & Current Ratings

600 Volts AC - UL Listed and C.S.A.

ATM-1 ¹ / ₁₀	ATM-3 ³ / ₄	ATM-4	ATM-12
ATM-1 ¹ / ₈	ATM-1	ATM-5	ATM-15
ATM-2 ² / ₁₀	ATM-1 ¹ / ₄	ATM-6	ATM-20
ATM-1 ¹ / ₄	ATM-1 ¹ / ₂	ATM-7	ATM-25
ATM-2 ² / ₁₀	ATM-2	ATM-7 ¹ / ₂	ATM-30
ATM-2 ² / ₁₀	ATM-2 ¹ / ₂	ATM-8	—
ATM-1 ¹ / ₂	ATM-3	ATM-9	—
ATM-2 ² / ₁₀	ATM-3 ¹ / ₂	ATM-10	—

*500 Volts AC/DC - UL Recognized and C.S.A.

TRM TRI-ONIC®

Time-Delay

Physical Size: 1³/₃₂" x 1¹/₂" (5 AG)
(10.3mm x 38.1mm)

Construction: Fibre Tube

Ampere Ratings: 1¹/₁₀-30 Amps.

Voltage Rating: 250 Volts AC

Interrupting Rating: 10,000A

Agency Information:

Std. 248-14
UL Listed; Guide JDYX; File E33925;
CSA Certified, Class 1422-01;
File 012636



TRM Catalog Symbol & Current Ratings

250 Volts AC

TRM-1 ¹ / ₁₀	TRM-1 ¹ / ₈	TRM-3 ³ / ₁₀	TRM-8
TRM-1 ¹⁵ / ₁₀₀	TRM-1 ¹ / ₄	TRM-3 ¹ / ₂	TRM-9
TRM-2 ² / ₁₀	TRM-1 ⁴ / ₁₀	TRM-4	TRM-10
TRM-1 ¹ / ₄	TRM-1 ⁹ / ₁₀	TRM-4 ¹ / ₂	TRM-12
TRM-2 ² / ₁₀	TRM-1 ⁸ / ₁₀	TRM-5	TRM-15
TRM-2 ² / ₁₀	TRM-2	TRM-5 ⁵ / ₁₀	TRM-20
TRM-1 ¹ / ₂	TRM-2 ¹ / ₄	TRM-6	TRM-25
TRM-2 ² / ₁₀	TRM-2 ¹ / ₂	TRM-6 ¹ / ₄	TRM-30
TRM-2 ² / ₁₀	TRM-2 ⁸ / ₁₀	TRM-7	—
TRM-1	TRM-3	—	—

ATQ AMP-TRAP®

Time-Delay

Physical Size: 1³/₃₂" x 1¹/₂" (5 AG) (10.3mm x 38.1mm)

Construction: Fibre Tube

Ampere Ratings: 1¹/₁₀-30 Amps.

Voltage Rating: 500V AC or less

Interrupting Rating: 10,000A RMS Sym.

Agency Information:

Std. 248-14
UL Listed, Guide JDYX, File E33925
CSA Certified, Class 1422-01, File 012636



ATQ Catalog Symbol & Current Ratings

500 Volts AC

ATQ-1 ¹ / ₁₀	ATQ-2 ² / ₁₀	ATQ-2	ATQ-5
ATQ-1 ¹ / ₈	ATQ-2 ² / ₁₀	ATQ-2 ¹ / ₄	ATQ-5 ⁵ / ₁₀
ATQ-1 ¹⁵ / ₁₀₀	ATQ-1	ATQ-2 ¹ / ₂	ATQ-6
ATQ-2 ² / ₁₆	ATQ-1 ¹ / ₈	ATQ-2 ⁸ / ₁₀	ATQ-6 ¹ / ₄
ATQ-2 ² / ₁₀	ATQ-1 ¹ / ₄	ATQ-3	ATQ-7
ATQ-1 ¹ / ₄	ATQ-1 ⁴ / ₁₀	ATQ-3 ³ / ₁₀	ATQ-8
ATQ-2 ² / ₁₀	ATQ-1 ¹ / ₂	ATQ-3 ¹ / ₂	ATQ-9
ATQ-2 ² / ₁₀	ATQ-1 ⁹ / ₁₀	ATQ-4	ATQ-10
ATQ-1 ¹ / ₂	ATQ-1 ⁸ / ₁₀	ATQ-4 ¹ / ₂	—

Catalog Symbol & Current Ratings

250 Volts

OTM-1	OTM-4	OTM-8	OTM-20
OTM-2	OTM-5	OTM-10	OTM-25
OTM-3	OTM-6	OTM-15	OTM-30



Catalog Symbol & Current Ratings

600 Volts AC

SBS- $\frac{2}{10}$	SBS-1	SBS-3	SBS-10
SBS- $\frac{4}{10}$	SBS-1 $\frac{1}{2}$	SBS-4	SBS-12
SBS- $\frac{1}{2}$	SBS-1 $\frac{6}{10}$	SBS-5	SBS-15
SBS- $\frac{3}{4}$	SBS-1 $\frac{8}{10}$	SBS-6	SBS-20
SBS- $\frac{8}{10}$	SBS-2	SBS-7	SBS-25
	SBS-8	SBS-30	



Midget Fuses

OTM - One-Time

Fast Acting

Physical Size: $\frac{1}{32}$ " x $\frac{1}{2}$ " (10.3mm x 38.1mm)

Construction: Fibre Tube; Nickel Plated Brass Endcaps

Voltage Rating: 250V AC ($\frac{2}{10}$ -15A), 125V AC (20-30A)

Interrupting Rating: 10,000A at 125V AC

Agency Information: Std. 248-14

UL 0-15/250V, Guide JDYX, File E33925

CSA Certified, 0-15/250V, Class 1422-01, File 012636

SBS - General Purpose

Fast Acting

Physical Size: $\frac{1}{32}$ " x $1\frac{3}{8}$ " (10.3mm x 35mm)

Construction: Fibre Cartridge

Voltage Rating: 600V AC

Interrupting Rating: 100,000A

Agency Information: Std. 248-14

UL 0-5/600V, Guide JDYX, File E33925

CSA Certified, 0-5A/600V, Class 1422-01, File 012636

Questions? Answers at...

(866) CED-ELEV • (866) 233-3538
www.cedlevator.com

TRI-ONIC® SmartSpot® Time-Delay Class RK5 Fuses

When sized properly...

- Provides motor overload, ground fault and short-circuit protection.
- Helps protect motors against burnout from overloads and from single phasing on three phase systems.
- Simplifies and improves blackout prevention (selective coordination).

TR (250V)

Dual Element Time Delay:

10 seconds (minimum) at 500% rated current

Ratings: AC: 1/10-600A, 250VAC, 200kA I.R.

DC: 1/10-2⁹/₁₀A & 35 to 400A, 250VDC, 20kA I.R.;
3 to 30A & 450 to 600A, 160VDC, 20kA I.R.

Current Limiting RK5 Fuse

Agency Information:

Std. 248-12, Class RK5
UL Listed, Guide JDDZ, File E2137
CSA Certified, Class 1422-01,
File 012636

TRS (600V)

Dual Element Time Delay:

10 seconds (minimum) at 500%
rated current

Ratings: AC: 1/10-600A, 600VAC, 200kA I.R.

DC: 1/10-12A, 600VDC, 20kA I.R.;
15 to 60A, 300VDC, 20kA I.R.
70 to 600A, 600VDC, 100kA I.R.

Current Limiting RK5 Fuse

Agency Information:

Std. 248-12, Class RK5
UL Listed, Guide JDDZ, File E2137
CSA Certified, Class 1422-02, File 012636



AGD(A)R (600V)

Dual Element Time Delay:

10 seconds (minimum) at 500% rated
current (8 seconds for 0-30A sizes)

Ampere Ratings: 1/10-600 Amps.

Voltage Rating: 600 Volts AC (or less),
300 Volts DC

Current Limiting RK1 Fuse

Interrupting Rating:

AC: 300,000A RMS Sym.
DC: 100,000A

Agency Information:

UL Listed - Special Purpose,*
Guide JFHR, File E2137
CSA Certified (200,000 A I.R.),
Class RK1 per CSA C22.2, No. 248.12,
Class 1422-02, File 012636

*Meets all performance requirements of
UL Standard 248-12 for Class RK1 fuses.



Catalog Numbers (250V AC/125V DC)

TR-1/10R	TR-2R	TR-10R	TR-100R
TR-1/8R	TR-2 1/4R	TR-12R	TR-110R
TR-15/100R	TR-2 1/2R	TR-15R	TR-125R
TR-2/10R	TR-2 9/10R	TR-17 1/2R	TR-150R
TR-1/4R	TR-3R	TR-20R	TR-175R
TR-3/10R	TR-3 3/10R	TR-25R	TR-200R
TR-4/10R	TR-3 1/2R	TR-30R	TR-225R
TR-1/2R	TR-4R	TR-35R	TR-250R
TR-6/10R	TR-4 1/2R	TR-40R	TR-300R
TR-8/10R	TR-5R	TR-45R	TR-350R
TR-1R	TR-5 9/10R	TR-50R	TR-400R
TR-1 1/8R	TR-6R	TR-60R	TR-450R
TR-1 1/4R	TR-6 1/4R	TR-70R	TR-500R
TR-1 3/10R	TR-7R	TR-75R	TR-600R
TR-1 1/2R	TR-7 1/2R	TR-80R	-
TR-1 9/10R	TR-8R	TR-85R	-
TR-1 9/10R	TR-9R	TR-90R	-

Catalog Numbers (600V AC/300V DC)

TRS-1/10R	TRS-2R	TRS-10R	TRS-100R
TRS-1/8R	TRS-2 1/4R	TRS-12R	TRS-110R
TRS-15/100R	TRS-2 1/2R	TRS-15R	TRS-125R
TRS-2/10R	TRS-2 9/10R	TRS-17 1/2R	TRS-150R
TRS-1/4R	TRS-3R	TRS-20R	TRS-175R
TRS-3/10R	TRS-3 3/10R	TRS-25R	TRS-200R
TRS-4/10R	TRS-3 1/2R	TRS-30R	TRS-225R
TRS-1/2R	TRS-4R	TRS-35R	TRS-250R
TRS-6/10R	TRS-4 1/2R	TRS-40R	TRS-275R
TRS-8/10R	TRS-5R	TRS-45R	TRS-300R
TRS-1R	TRS-5 9/10R	TRS-50R	TRS-325R
TRS-1 1/8R	TRS-6R	TRS-60R	TRS-350R
TRS-1 1/4R	TRS-6 1/4R	TRS-70R	TRS-400R
TRS-1 3/10R	TRS-7R	TRS-75R	TRS-450R
TRS-1 1/2R	TRS-7 1/2R	TRS-80R	TRS-500R
TRS-1 9/10R	TRS-8R	TRS-85R	TRS-600R
TRS-1 9/10R	TRS-9R	TRS-90R	-

Catalog Numbers (600V AC/300V DC)

AGD-1/10RSP	AGD-2 1/2RSP	AGD-12RSP	AGD-110RSP
AGD-3/10RSP	AGD-2 9/10RSP	AGD-15RSP	AGD-125RSP
AGD-3/10RSP	AGD-3RSP	AGD-17 1/2RSP	AGD-150RSP
AGD-4/10RSP	AGD-3 3/10RSP	AGD-20RSP	AGD-175RSP
AGD-1/2RSP	AGD-3 1/2RSP	AGD-25RSP	AGD-200RSP
AGD-6/10RSP	AGD-4RSP	AGD-30RSP	AGD-225RSP
AGD-8/10RSP	AGD-4 1/2RSP	AGD-35RSP	AGD-250RSP
AGD-1RSP	AGD-5RSP	AGD-40RSP	AGD-300RSP
AGD-1 1/8RSP	AGD-5 9/10RSP	AGD-45RSP	AGD-350RSP
AGD-1 1/4RSP	AGD-6RSP	AGD-50RSP	AGD-400RSP
AGD-1 3/10RSP	AGD-6 1/4RSP	AGD-60RSP	AGD-450RSP
AGD-1 1/2RSP	AGD-7RSP	AGD-70RSP	AGD-500RSP
AGD-1 9/10RSP	AGD-8RSP	AGD-80RSP	AGD-600RSP
AGD-1 9/10RSP	AGD-9RSP	AGD-90RSP	-
AGD-2 1/4RSP	AGD-10RSP	AGD-100RSP	-

Questions? Answers at...
(866) CED-ELEV • (866) 233-3538
www.cedlevator.com

Current Rating	Max. Rated Voltage AC	Current Rating	Max. Rated Voltage AC
1/8	250V	5	250V
1/4	250V	6	250V
3/8	250V	7	250V
1/2	250V	8	250V
3/4	250V	10	250V
1	250V	12	250V
2	250V	15	250V
2 1/2	250V	20	250V
3	250V	25	250V
4	250V	30	250V

Current Rating	Rated Voltage (Max.)		Current Rating	Rated Voltage (Max.)	
	AC	DC ^{1,2}		AC	DC ^{1,2}
1/100	250V	250V	1 1/4	250V	250V
1/32	250V	250V	1 1/2	250V	250V
1/16	250V	250V	1 3/4	250V	250V
1/10	250V	250V	1 9/10	250V	250V
1/8	250V	250V	2	250V	250V
1 5/100	250V	250V	2 1/4	250V	250V
1 75/1000	250V	250V	2 1/2	250V	250V
3/16	250V	250V	3	250V	250V
2/10	250V	250V	3 3/10	250V	250V
1/4	250V	250V	4	250V	250V
3/10	250V	250V	5	250V	250V
3/8	250V	250V	6	250V	250V
4/10	250V	250V	6 3/10	250V	250V
1/2	250V	250V	7	32V	32V
6/10	250V	250V	7 1/2	32V	32V
3/4	250V	250V	8	32V	32V
8/10	250V	250V	10	32V	32V
1	250V	250V	12	250V	250V

Current Rating	Rated Voltage (Max.)		Current Rating	Rated Voltage (Max.)	
	AC	DC ^{1,2}		AC	DC ^{1,2}
1/16	250V	250V	1 1/4	250V	250V
1/10	250V	250V	1 1/2	250V	250V
1/8	250V	250V	1 9/10	250V	250V
1 5/100	250V	250V	1 9/10	250V	250V
1 75/1000	250V	250V	2	250V	250V
3/16	250V	250V	2 1/4	250V	250V
2/10	250V	250V	2 1/2	250V	250V
1/4	250V	250V	2 9/10	250V	250V
3/10	250V	250V	3	250V	250V
3/8	250V	250V	3 3/10	250V	250V
4/10	250V	250V	4	250V	250V
1/2	250V	250V	5	250V	250V
6/10	250V	250V	6	250V	250V
7/10	250V	250V	6 1/4	250V	250V
3/4	250V	250V	7	250V	250V
8/10	250V	250V	8	250V	250V
1	250V	250V	10	32V	32V

¹DC ratings are self certified. ²0-8A is UL listed for 125VDC.



GAB

Fast-Acting

Physical Size: 1/4" x 1 1/4" (3AB) (6.3mm x 32mm)

Construction: Ceramic Tube

Nickel Plated Brass End Caps

Agency Information: Std. 248-14

UL Listed, Guide JDYX File E90660, 0-15A

UL Recognized, Guide JDYX2, File E19180, 20-25A

CSA Certification, Class 1422-01, File 53787,

0-15A, Class 1422-30, File 53787, 20-25A



GGC

GGC-V (Axial Leads)

Fast-Acting

Physical Size: 1/4" x 1 1/4" (3AG) (6.3mm x 32mm)

Construction: Glass Tube

Nickel Plated Brass End Caps

Agency Information: Std. 248-14

UL Listed, Guide JDYX, File E90660, 0-10A

UL Recognized, Guide JDYX2, File E19180, 15-30A

CSA Certification, Class 1422-01, File 53787



GDL

GDL-V (Axial Leads)

Time-Delay

Physical Size: 1/4" x 1 1/4" (3AG) (6.3mm x 32mm)

Construction: Glass Tube

Nickel Plated Brass End Caps

Agency Information: Std. 248-14

UL Listed, Guide JDYX, File E90660; 1/16-8A

CSA Certification Class 1422-01, File 53787, 1/16-8A

UL Recognized, Guide JDYX2, File E19180, 8.1-30A

Additional sizes available upon request.

Electronic Fuses N. American Standards

GGM

GGM-V (Axial Leads)

Fast-Acting

Physical Size: 0.197" x 0.788" (5mm x 20mm)

Construction: Glass Tube, Nickel Plated Brass End Caps

Agency Information: Std. 248-14

UL Listed Guide JDYX, File E90660, 1/10-3

UL Recognized, Guide JDYX2, File E90660, 7-15A

CSA Certified, Class 1422-01, File E90660, 0-6A

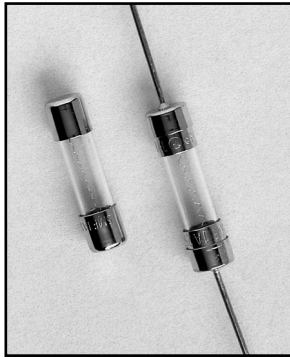

Current Ratings

Rated Voltage: **250V AC**

Breaking Capacity: 35A/250V, 10kA/125V, p.f. = 0.7-0.8

63mA	200mA	315mA	750mA
------	-------	-------	-------

100mA	250mA	500mA	800mA
-------	-------	-------	-------

125mA	300mA	600mA	1A
-------	-------	-------	----

Breaking Capacity: 100A/250V, 10kA/125V, p.f. = 0.7-0.8

1.25A	1.5A	1.6A	2A	2.5A
-------	------	------	----	------

Rated Voltage: **125V AC**

Breaking Capacity: 10kA/125V, p.f. = 0.7-0.8

3.15A	3.5A	5A	4A	6A
-------	------	----	----	----

Breaking Capacity: 200A/125V, p.f. = 1.0

7A	8A
----	----

Breaking Capacity: 150A/125V, p.f. = 1.0

10A	15A
-----	-----

GSC

GSC-V (Axial Leads)

Medium Time-Delay

Physical Size: 0.197" x 0.788" (5mm x 20mm)

Construction: Glass Tube, nickel plated brass end caps

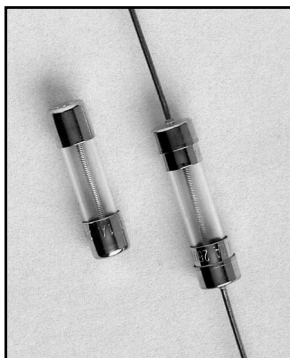

Current Ratings

Rated Voltage: **250V AC**

Breaking Capacity: 35A/250V, 10kA/125V, p.f. = 0.7-0.8

63mA	150mA	315mA	630mA
------	-------	-------	-------

80mA	200mA	400mA	750mA
------	-------	-------	-------

100mA	250mA	500mA	800mA
-------	-------	-------	-------

125mA	300mA	600mA	1A
-------	-------	-------	----

Breaking Capacity: 100A/250V, 10kA/125V, p.f. = 0.7-0.8

1.25A	1.6A	2.5A	3A	3.15A
-------	------	------	----	-------

1.5A	2A
------	----

Rated Voltage: **125V AC**

Breaking Capacity: 10kA/125V, p.f. = 0.7-0.8

3.5A	4A	5A	6A
------	----	----	----

Breaking Capacity: 200A/125V, p.f. = 1.0

6.3A	7A	8A	10A
------	----	----	-----

Electrical Characteristics

Current Rating	I ² t	Max Voltage Drop (mV)	Current Rating	I ² t	Max Voltage Drop (mV)
50mA	0.0017	9000	630mA	0.064	1200
63mA	0.0005	3300	800mA	0.097	490
80mA	0.0011	2600	1A	0.480	230
100mA	0.0018	2300	1.25A	0.9	200
125mA	0.0037	1900	1.6A	1.9	180
160mA	0.008	1600	2A	2.0	205
200mA	0.020	1350	2.5A	3.9	190
250mA	0.027	1300	3.15A	8.1	160
315mA	0.010	1400	4A	14	160
400mA	0.018	1200	5A	25	155
500mA	0.038	1050	6.3A	48	150

Electrical Characteristics

Current Rating	I ² t	Max Voltage Drop (mV)	Current Rating	I ² t	Max Voltage Drop (mV)
32mA	0.0014	1050	500mA	0.75	168
40mA	0.0034	920	630mA	1.3	158
50mA	0.006	800	800mA	3.1	132
63mA	0.012	760	1A	3.6	85
80mA	0.015	580	1.25A	7	80
100mA	0.022	490	1.6A	10	80
125mA	0.034	390	2A	17	80
160mA	0.052	320	2.5A	34	80
200mA	0.078	340	3.15A	56	75
250mA	0.17	270	4A	91	75
315mA	0.41	250	5A	133	75
400mA	0.61	210	6.3A	270	65

Electronic Fuses IEC Standards

GSD

GSD-V (Axial Leads)

Fast-Acting, High Breaking Capacity

Physical Size: 0.197" x 0.788" (5mm x 20mm)

Construction: Ceramic Tube, Nickel Plated Brass Endcaps

Voltage Rating: 250V AC or less

Interrupting Rating: 1500A @ 250V AC

Agency Information: UL Recognized, Guide JDYX2, File E75865, 50mA and 315mA-6.3A
SEMKO Approval 50mA, 200mA and 315mA-6.3A
IEC 127-SI

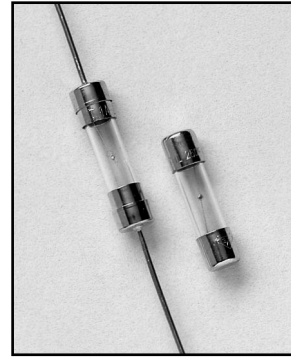

GDG

GDG-V (Axial Leads)

Time Delay, Low Breaking Capacity

Physical Size: 0.197" x 0.788" (5mm x 20mm)

Construction: Ceramic Tube, Nickel Plated Brass Endcaps

Voltage Rating: 250V AC or less

Interrupting Rating: 35A @ 250V AC

Agency Information: Designed to IEC (Pub 127) Sheet III
British Standard Approval
SEMKO Approval; VDE Approval, IMQ
UL Recognized, Guide JDYX2, File E75865, 32mA-6.3A

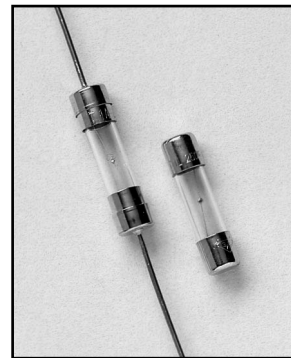

One-Time General Purpose Fuses

OTN & OTS - One-Time

General Purpose, Non-Current Limiting

Ampere Ratings: 1/8–600 Amps.

Voltage Rating:

NON: 250 Volts AC, 125 Volts DC (0–100A);
NOS: 600 Volts AC

Interrupting Rating: 50,000A RMS Sym. (1–60A),
10,000A RMS Sym. (65–600A)
10,000A @ 125V DC (NON 0–100A)

Agency Information:

UL Listed 250V: Class K5 (0–60A), Std. 248-9
Class H (65–600A), Std. 248-6
600V: Class K5 (0–60A), Std. 248-9
Class H (70–600A), Std. 248-6
Guide JDDZ, File E2137
CSA Certified – 250V: (0–12, 65–600) 600V: (0–600)
Class 1421-01, File 012636



Catalog Numbers (250V AC)

OT-1/8	OT-5	OT-40	OT-175
OT-1/2	OT-6	OT-45	OT-200
OT-3/4	OT-6 1/4	OT-50	OT-225
OT-8/10	OT-7	OT-60	OT-250
OT-1	OT-8	OT-65	OT-300
OT-1 1/4	OT-9	OT-70	OT-350
OT-1 1/2	OT-10	OT-75	OT-400
OT-1 6/10	OT-12	OT-80	OT-450
OT-2	OT-15	OT-90	OT-500
OT-2 1/2	OT-20	OT-100	OT-600
OT-3	OT-25	OT-110	–
OT-3 2/10	OT-30	OT-125	–
OT-4	OT-35	OT-150	–

Catalog Numbers (600V AC)

NOS-1	OTS-12	OTS-70	OTS-200
OTS-2	OTS-15	OTS-75	OTS-225
OTS-3	OTS-20	OTS-80	OTS-250
OTS-4	OTS-25	OTS-90	OTS-300
OTS-5	OTS-30	OTS-100	OTS-350
OTS-6	OTS-35	OTS-110	OTS-400
OTS-7	OTS-40	OTS-125	OTS-450
OTS-8	OTS-45	OTS-150	OTS-500
OTS-9	OTS-50	OTS-175	OTS-600
OTS-10	OTS-60	–	–

High-Speed Semiconductor Fuses

A30QS 250V Electrical Characteristics

Part Number	Rated Current RMS-Amps	I ² t (A ² SEC)			Part Number	Rated Current RMS-Amps	I ² t (A ² SEC)		
		Pre-Arc	Clearing at 250V	Watts Loss			Pre-Arc	Clearing at 250V	Watts Loss
A30QS-35-4	35	50	230	4.2	A30-275-4	275	4720	21600	31
A30QS-40-4	40	60	310	5.2	A30-300-4	300	6000	27300	32
A30QS-45-4	45	80	390	5.7	A30-350-4	350	10600	48600	39
A30QS-50-4	50	100	520	6.0	A30-400-4	400	14500	66100	44
A30QS-60-4	60	140	740	8.1	A30-450-4	450	22100	101000	49
A30QS-70-4	70	330	1400	7.2	A30-500-4	500	28000	128000	54
A30QS-80-4	80	430	1850	8.1	A30-600-4	600	41100	188000	62
A30QS-90-4	90	570	2450	9.0	A30-700-4	700	48800	190000	72
A30QS-100-4	100	740	3150	10.0	A30-800-4	800	59000	230000	84
A30QS-125-4	125	1130	4850	12.5	A30-1000-128	1000	44000	360000	100
A30QS-150-4	150	1620	6950	15.7	A30-1200-128	1200	92000	750000	103
A30QS-175-4	175	2170	9300	18.5	A30-1500-128	1500	120000	880000	140
A30QS-200-4	200	2790	12000	22	A30-1600-128	1600	160000	1200000	140
A30QS-225-4	225	3210	14700	24	A30-2000-128	2000	320000	2300000	151
A30QS-250-4	250	3960	18100	27	A30-2500-128	2500	670000	4700000	163

A50QS 500V Electrical Characteristics

Part Number	Rated Current RMS-Amps	I ² t (A ² SEzC)			Part Number	Rated Current RMS-Amps	I ² t (A ² SEC)		
		Pre-Arc	Clearing at 500V	Watts Loss			Pre-Arc	Clearing at 500V	Watts Loss
A50P-35-4	35	34	150	.8	A50QS-225-4	225	4600	23300	39
A50P-40-4	40	76	320	7.5	A50QS-275-4	275	7900	40300	46
A50P-45-4	45	105	450	7.5	A50QS-300-4	300	9800	49800	51
A50P-50-4	50	135	670	7.5	A50QS-325-4	325	13700	63800	53
A50P-60-4	60	210	900	9.9	A50QS-350-4	350	14500	72900	58
A50P-70-4	70	210	900	10.6	A50QS-400-4	400	19200	96700	65
A50P-80-4	80	305	1400	12.7	A50QS-450-4	450	24700	127000	74
A50P-90-4	90	360	1600	15	A50QS-500-4	500	29200	149000	84
A50P-100-4	100	475	2000	17	A50QS-600-4	600	41300	206000	108
A50P-125-4	125	800	3500	25	A50QS-700-4	700	55000	298000	120
A50P-150-4	150	1100	4600	30	A50QS-800-4	800	76200	409000	129
A50P-175-4	175	1450	6200	35	A50QS-1000-4	1000	92000	450000	145
A50P-200-4	200	1900	8500	40	A50QS-1200-4	1200	122000	600000	180

A70QS 700V Electrical Characteristics

Part Number	Rated Current RMS-Amps	I ² t (A ² SEC)			Part Number	Rated Current RMS-Amps	I ² t (A ² SEC)		
		Pre-Arc	Clearing at 700V	Watts Loss			Pre-Arc	Clearing at 250V	Watts Loss
A70Q-5B	5	1.6	10	1.5	A70QS-175-4K	175	4200	16700	35
A70Q-10B	10	3.6	20	4	A70QS-200-4K	200	5500	22000	43
A70Q-15B	15	10	75	5.5	A70QS-225-4	225	7700	31300	45
A70Q-20B	20	26	180	6	A70QS-250-4	250	10500	42500	48
A70Q-25B	25	44	340	7	A70QS-300-4	300	17600	71200	58
A70Q-30B	30	58	450	9	A70QS-350-4	350	23700	95600	65
A70Q-35B	35	34	160	12	A70QS-400-4	400	31000	125000	78
A70Q-40B	40	76	320	12	A70QS-450-4K	450	36400	137000	94
A70Q-50B	50	135	600	12	A70QS-500-4K	500	45200	170000	107
A70Q-60B	60	210	950	15.5	A70QS-600-4K	600	66700	250000	122
A70Q-70B	70	305	1400	18	A70QS-700-4K	700	54000	300000	125
A70Q-80B	80	360	1600	21	A70QS-800-4K	800	78000	450000	140
A70Q-90B	90	415	1900	25	A70QS-900-4K	900	91500	530000	150
A70Q-100B	100	540	2500	27	A70QS-1000-4K	1000	120000	600000	170
A70QS-125A	125	1800	7300	28	A70QS-1200-4K	1200	195000	1100000	190
A70QS-150A	150	2900	11700	32					

Questions? Answers at...
 (866) CED-ELEV • (866) 233-3538
www.cedlevator.com

Fuse Reference Table

MERSEN #	BUSSMANN#	LITTELFUSE #	MERSEN #	BUSSMANN#	LITTELFUSE #	MERSEN #	BUSSMANN#	LITTELFUSE #
GDL1/10	MDL 1/10	313.01	GAB1/4	ABC-1/4	314.25	ATDR1	FNQR1	KLDR1
GDL3/4	MDL 3/4	313.75	GAB1/2	ABC1/2	314.500	ATDR1/2	FNQR1/2	KLDR1/2
GGC2	AGC2	312002	GGC3/4	ABC-3/4	314.75	ATDR1/4	FNQR1/4	KLDR1/4
	GMA-500MA	235.500	GAB1	ABC1	314001	ATDR1/4	FNQ-R-1/4	KLDR1/4
	GMA1A	235001	GAB2	ABC2	314002	ATDR1/8	FNQR1/8	KLDR1/8
GGM4	GMA-4A	235004	GAB3	ABC-3	314003	ATDR10	FNQR10	KLDR10
	GMC-500MA	239.500	GAB4	ABC-4	314004	ATDR1-1/2	FNQR1-1/2	KLDR1-1/2
	GMC-1A	239001	GAB5	ABC5	314005	ATDR1-1/4	FNQR1-1/4	KLDR1-1/4
GSC3	GMC3A	239003	GAB6	ABC-6	314006	ATDR1-1/8	FNQR1-1/8	KLDR1-1/8
GSRV1/16	MCR-1/16	251.062	GAB7	ABC-7	314007	ADTR1-4/10	FNQR1-4/10	find
GSRV1/8	MCR-1/8	251.125	GAB8	ABC8	314008	ATDR1-6/10	FNQR1-6/10	KLDR1-6/10
GSRV1/4	MCR-1/4	251.25	GAB10	ABC10	314010	ATDR2	FNQR2	KLDR2
GSRV3/8	MCR-3/8	251.375	GAB12	ABC-12	314012	ATDR2-1/2	FNQR2-1/2	KLDR2-1/2
GSRV1/2	MCR-1/2	251.5	GAB15	ABC15	314015	ATDR2-1/4	FNQR2-1/4	KLDR2-1/4
GSRV3/4	MCR-3/4	251.75	GAB20	ABC-20	314020	ATDR2-8/10	FNQR2-8/10	KLDR2-8/10
GSRV1	MCR1	251001	GAB25	ABC25	314025	ATDR3	FNQR3	KLDR3
GSRV2	MCR2	251002	GSA10	MDA-10	326010	ATDR3/10	FNQR3/10	KLDR3/10
GSRV3	MCR-3	251003	GSA15	MDA-15	326015	ATDR3/4	FNQR3/4	KLDR3/4
GSRV4	MCR4	251004	ATDR10		CCMR10	ATDR3-1/2	FNQR3-1/2	KLDR3-1/2
GSRV5	MCR-5	251005	ATDR1 1/4		CCMR1-1/4	ATDR4	FNQR4	KLDR4
GSRV7	MCR-7	251007		LP-CC-20	CCMR20	ATDR4/10	FNQR4/10	KLDR4/10
GSRV1-1/2	MCR-1 1/2	25101.5	ATDR4		CCMR4	ATDR5	FNQR5	KLDR5
GSRV10	MCR-10	251010	ATDR5		CCMR5	ATDR6	FNQR6	KLDR6
GSRV2-1/2	MCR-2 1/2	25102.5	ATDR6		CCMR6	ATDR6/10	FNQR6/10	KLDR6/10
GSRV3-1/2	MCR-3 1/2	25103.5	TRM30	FNW-30	FLM-30	ATDR6-1/4	FNQR6-1/4	KLDR6-1/4
		273001	TR 1R	FRNR1	FLN-R 1	ATDR7	FNQR7	KLDR7
		273004	TR 1 8/10 R	FRNR1-8/10	FLN-R 1 8/10	ATDR7-1/2	FNQR7-1/2	KLDR7-1/2
GGC1/8	AGC-1/8	312.125	TR 10R	FRN-R 10	FLN-R 10	ATDR8	FNQR8	KLDR8
GGC3/8	AGC-3/8	312.375	TR 15R	FRN-R 15	FLN-R 15	ATDR8/10	FNQR8/10	KLDR8/10
GGC3/8	AGC3/8	312.375	TR 17 1/2 R	FRN-R 17 1/2	FLN-R 17 1/2	ATDR9	FNQR9	KLDR9
GGC1/2	AGC1/2	312.500	TR 2R	FRNR2	FLN-R 2	ATM1/2	KTK 1/2	KLK 1/2
GGC3/4	AGC-3/4	312.75	TR 2 1/2 R	FRNR2-1/2	FLN-R 2 1/2		KLM-1	KLK D 1
GGC1	AGC1	312001	TR 20R	FRN-R 20	FLN-R 20		KLM-2	KLK D 2
GGC1	AGC1	312001	TR 25R	FRN-R 25	FLN-R 25	ATM1	KTK1	KLK1
GGC3	AGC3	312003	TR 3R	FRNR3	FLN-R 3	ATM1/10	KTK 1/10	KLK1/10
GGC3	AGC-3	312003	TR 30R	FRN-R 30	FLN-R 30	ATM1/10	KTK 1/10	KLK1/10
GGC4	AGC4	312004	TR 35R	FRNR35	FLN-R 35	ATM1/4	KTK 1/4	KLK1/4
GGC5	AGC5	312005	TR 4R	FRNR4	FLN-R 4	ATM1/8	KTK 1/8	KLK1/8
GGC6	AGC6	312006	TR 40R	FRN-R 40	FLN-R 40	ATM10	KTK10	KLK10
GGC1-1/2	AGC112F	31201.5	TR 50R	FRN-R 50	FLN-R 50	ATM1-1/2	KTK 1 1/2	KLK1-1/2
GGC10	AGC10	312010	TR 6R	FRN-R 6	FLN-R 6	ATM12	KTK 12	KLK12
GGC10	AGC10	312010	TR 6 1/4 R	FRNR614F	FLN-R 6 1/4	ATM15	KTK15	KLK15
GDL1	MDL 1	313 001	TR 60R	FRNR60	FLN-R 60	ATM2	KTK2	KLK2
GDL1	MDL1	313 001	TR 7R	FRN-R 7	FLN-R 7	ATM2/10	KTK 2/10	KLK2/10
GDL2	MDL2	313 002	TR 8R	FRN-R 8	FLN-R 8	ATM20	KTK20	KLK20
GDL3	MDL3	313 003	TR-R-100	FRNR100	FLNR100	ATM2-1/2	KTK 2 1/2	KLK2-1/2
GDL4	MDL-4	313 004	TRSR10	FRSR10	FLSR10	ATM25	KTK 25	KLK25
GDL5	MDL5	313 005	TRSR15	FRSR15	FLSR15	ATM3	KTK3	KLK3
GDL7	MDL7	313 007	TRSR20	FRSR20	FLSR20	ATM3/10	KTK 3/10	KLK3/10
GDL1-1/2	MDL1-1/2	313 01.5	TRSR25	FRSR25	FLSR25	ATM30	KTK30	KLK30
GDL10	MDL10	313 010	TRSR3	FRSR3	FLSR3	ATM3-1/2	KTK 3 1/2	KLK3-1/2
GDL12	MDL-12	313 012	TRSR30	FRSR30	FLSR30	ATM4	KTK4	KLK4
GDL15	MDL15	313 015	TRSR4	FRSR4	FLSR4	ATM5	KTK5	KLK5
GDL2-1/2	MDL2 1/2	313 02.5	TRSR40	FRSR40	FLSR40	ATM6	KTK6	KLK6
GDL20	MDL20	313 020	TRSR5	FRSR5	FLSR5	ATM7	KTK 7	KLK7
GDL25	MDL-25	313 025	TRSR6	FRSR6	FLSR6	ATM8	KTK8	KLK8
GDL3-2/10	MDL3-2/10	313 03.2		LPJ-17 1/2 SP	JTD 17 1/2	ATM9	KTK 9	KLK9
GDL30	MDL-30	313 030	AJT20	LPI-20 SP	JTD 20	ATMR15	KTKR15	KLKR15
GDL1-1/4	MDL1-1/4	313 1.25	AJT25	LPI-25 SP	JTD 25	ATMR5	KTKR5	KLKR5
GDL2-1/4	MDL-2 1/4	313 2.25	AJT30	LPI-30 SP	JTD 30	ATMR6	KTK-R 6	KLKR6
GDL6-1/4	MDL614F	313 6.25	AJT35	LPI-35 SP	JTD 35	OT1	NON1	NLN1
GDL1/16	MDL116F	313.062	AJT40	LPI-40 SP	JTD 40	OT10	NON10	NLN10
GDL1/8	MDL18F	313.125	AJT45	LPI-45 SP	JTD 45	OT100	NON100	NLN100
GDL1/4	MDL1/4	313.25	AJT60	LPI-60 SP	JTD 60	OT15	NON15	NLN15
GDL1/2	MDL1/2	313.5	AJT70	LPI-70 SP	JTD 70	OT2	NON2	NLN2

(CONTINUED NEXT PAGE)

Questions? Answers at...
(866) CED-ELEV • (866) 233-3538
www.cedelevator.com

Fuse Reference Table

MERSEN #	BUSSMANN#	LITTELFUSE #	MERSEN #	BUSSMANN#	LITTELFUSE #	MERSEN #	BUSSMANN#	LITTELFUSE #
GDL3/4	MDL3/4	313.75	ATDR1-8/10	FNQR1-8/10	KLDR01-8/10			
OT20	NON20	NLN20		PCC 3/4			BBS4	
OT25	NON25	NLN25		GDC-125MA			170M1370	
OT3	NON3	NLN3		GDC-3.15A			GDA-2A	
OT40	NON40	NLN40	GDG4	GDC4A		TRM1/2	FNM1/2	
OT5	NON5	NLN5	GDG5	GDC5A		TRM2	FNM2	
OT6	NON6	NLN6		GDC-6.3A		TRM2-1/2	FNM2-1/2	
OT60	NON60	NLN60		5505-500MA		TRM10	FNM10	
OT7	NON7	NLN7		5505-1A		A25X6-1	KAB6	
OT8	NON8	NLN8		5505-2A			FWX15A14F	
OTS1	NOS1	NLS1		GDC-250MA			MIN1	
OTS10	NOS10	NLS10		GDC-500MA			MIN3	
OTS15	NOS15	NLS15		GDC-800MA			MIN5	
OTS20	NOS20	NLS20		GDC1A			MIN10	
OTS25	NOS25	NLS25		GDC-1.25A			MIN15	
OTS3	NOS3	NLS3		GDC-1.6A			KAZ	
OTS30	NOS30	NLS30		GDC-2A		A70P600-4	FWP600A	
OTS4	NOS4	NLS4		GDC-2.5A		A70P400-4	FWP400A	
OTS40	NOS40	NLS-40	A100P70-4			A70P500-4	FWP500A	
OTS6	NOS6	NLS6	A50P500-4	FWH-500A			FWJ100A	
OTS60	NOS60	NLS60	A70P250-4	FWP-250A		AJT6	LPJ6SP	
OTS8	NOS8	NLS8	A70P300-4	FWP-300A		AJT10	LPJ10SP	
	SFT-125MA	R459.125	A70P350-4	FWP-350A		AJT15	LPJ15SP	
	SFT-250MA	R459.250	A70P400-4	FWP-400A			FWJ150A	
	SFT-500MA	R459.500	A70P450-4	FWP-450A		A25X60-1	FWX60A	
	SFT-1	R459001	A70P500-4	FWP-500A			FWP10A14F	
	SC-35	SLC-35	A50QS200-4			TI-600		
	SC-45	SLC-45	A50QS125-4			A100P100		
	2430-1		A70Q90-4			TI-1500		
	2430-4		A100P100-4TI			A100P300		
GTH4	MTH4		A70Q200-4			A100P350		
GTH5	MTH5		A100P150-4TI			60306	H600301 CR	
GTH6	MTH6		A100P200-4				HKLX	
	S8202-02		A50P250-4	FWH-250A		61036	H601001 CR	
	S8202-03		A50P300-4	FWH-300A		20322	H250302P	
	S82021		A50P350-4	FWH-350A			HRJ	
	R25030-1CR		A50P400-4	FWH-400A			2610	
30313R			A50P450-4	FWH-450A			S80021	
DFC3M			G5B5			20323	H250303P	
	GDB2A			GDA-4A			38233	
	FWP250A		GGM2	GMA-2			38236	
	FWP300A		GGM3	GMA-3			GBB10	
ATQ1	FNQ1		AJT10	LPJ10SP		GW10	W10	
ATQ2	FNQ2		GSA25	BKMDA25		GFN2	FNA2	
ATQ3	FNQ3		A25X3-1	KAB3		GGC15	AGC15	
ATQ4	FNQ4		A25X5-1	KAB5		GGC1/32	AGC1/32	
ATQ4-1/2	FNQR4-1/2		A25X15-1	KAB15		GGC6	AGC6	
ATQ5	FNQ5		A25X25-1	KAB25		A2K30R	KTNR30	
ATQ8	FNQ8			1A3400-09		A2K6R	KTNR6	
ATQ9	FNQ9			1A1119-10		A70P125	FWP125A	
ATQ10	FNQ10			1A1907-03		A70P150	FWP150A	
ATQ15	FNQ15			HBW-1		A70P200	FWP200A	
ATQ20	FNQ20			HPS			MIN2	
ATQ3/16	FNQ3/16		30323R	BC6033P		OTS70	NOS70	
ATDR1-3/10	FNQR1-3/10		30322R	BC6032P		A25X350-4	FWX350A	
	FP-A3		30323R	BC6033P		A50P200-4	FWH200A	
	MDQ8A		60358R			A50P250-4	FWH250A	
	SAMI-7N			1A3400-09		A50P300-4	FWH300A	
ATQ 10	FNQ10			BKSTM		A50P400-4	FWH400A	
TRM 3 1/2	FNM3-1/2			HTB-32M		A50P500-4	FWH500A	
ATQ 2	FNQ2		GSC2	GMC-2A		TRM7	FNM7	
	FRNR1-6/10		GDG1	GDC1A		GGC6-1/4	AGC6-1/4	
	FRNR3-2/10		GDG5	GDC5A		OTM1	BAN1	
	FRNR5			170L4278		TRM3	FNM3	
	BK/PCS			BBS12F		TRM5	FNM5	
	BKPCB1.5			BBS810F				
	BKPCB2.5			BBS2				
	BKPC 1.5A			BBS3				

Questions? Answers at...

Western US: 866 CED-ELEV Eastern US: 866-253-2915
 or 866-233-3538 • Fax 562-427-8429 or 860-256-2211 • Fax 860-290-8970

The products listed on this page are manufactured by
Bussmann

GENERAL PURPOSE

9

In this Section

Orange Sticks	9.2
Pit Pads	9.2
Aluminum Wall Panel Splines . . .	9.2
Material Hooks	9.2
Custom Pit Ladder Worksheet . . .	9.3
Stepladders	9.4
Floor Protection	9.5-6
Tape (Friction, Rubber, Electrical)	9.6
Key Switches	9.7-9.8
LED's (Key Switches & Hall Lanterns)	9.9
ELSCO Roller Guides	9.10-9.12
Astragals	9.13
Burnishing & Polishing Tools . . .	9.13
Martindale Abrasives	9.14-9.15
Electronics Chime w/Timer	9.16
Emergency Light Unit	9.16
Hatch Latch	9.17
Soft Stop "Anti-Chatter"	9.17
Selector Tape Guide	9.17

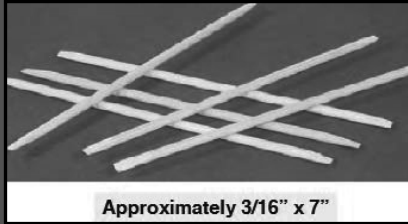

Approximately 3/16" x 7"

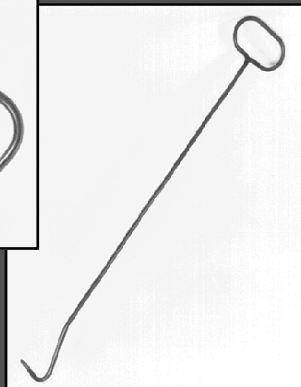
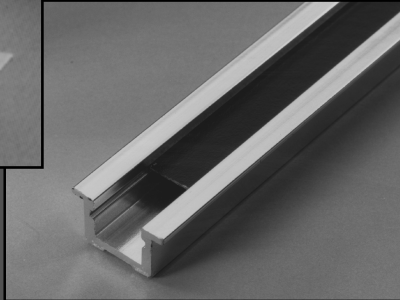
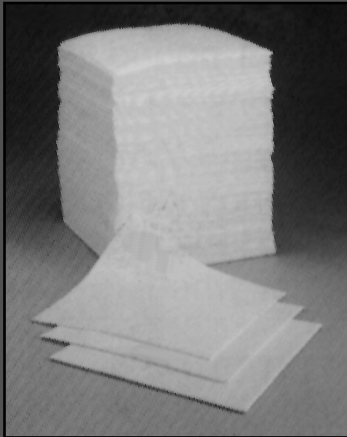

Orange Sticks , Oil Clean-up & Splines

Orange Sticks

Orange Sticks (called so because they were originally made from orange wood) can be used for forming, shaping and positioning fine magnet wire where fingers can't reach or work comfortably. Also used for opening and holding open, contacts on relays, probing energized circuits for finding poor connections and faults and PCB repairs. These hardwood, non conductive, sticks have tapered ends for prying open contacts and can be trimmed and/or sharpened with a knife.

Non-conductive, 10 per pack

Part Number	Description
AS60W6	Orange Sticks

Pit Pads

For oil clean-up. Absorb oil, not water. Clean easier and more efficiently than granular type cleaners. Absorb 25 times their own weight. Box of 100, 12oz, 17"x 3/8" polypropylene pads.

Part Number	Description
ATGPB-H	Pit Pads

Aluminum Wall Panel Splines

For mounting reversible and/or replaceable wall panels on car interior walls. Splines include a black plastic laminate insert strip.

Part Number	Description
ASC	Chrome Finish
ASB	Bronze Finish

Material Hooks

Put a handle on your guide rails with less pain, less strain. Hooks are either parallel or at right angle to the handle, 12" or 36" long overall.

Part Number	Description
11-403	12"
11-404	36"

Ladder Worksheet

Name: _____ Date: _____

Email: _____ Phone: _____

Company: _____

Address: _____

Job Name: _____

Required Data:

- A. Overall Ladder Length _____
- B. Pit Depth _____
- C. Ladder Width (16" minimum per CA Code) _____
- D. Extra Brackets, distance (if required) _____
- E. Welded Wall Brackets (2 Standard) _____
- F. Quantity of Rungs (5 Standard) _____
- G. Bolted Bracket Required? YES / NO
- H. Collapsible Required? YES / NO
- I. Quantity of Ladders _____

Ladders come standard Painted Machine Grey. Galvanized available for additional charge.

Additional Notes:

Front View

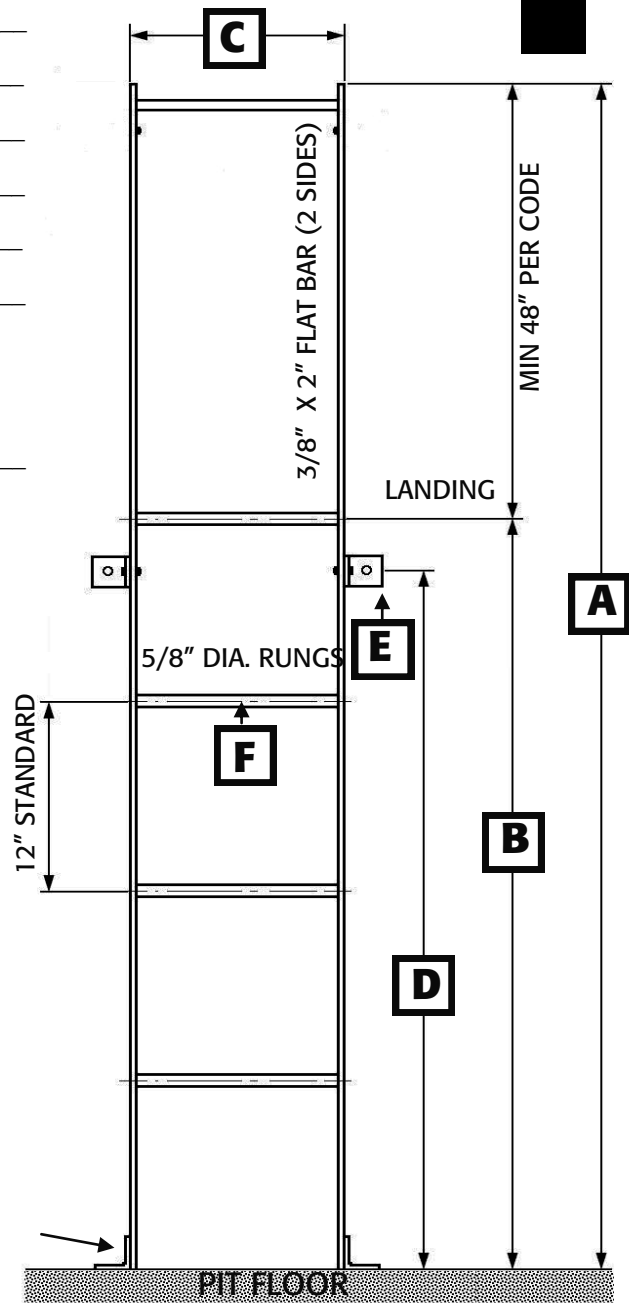

Top View

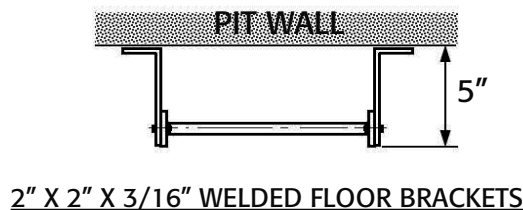

LADDERS ARE CUSTOM MADE AND NON-RETURNABLE. PLEASE RE-CHECK BEFORE SUBMITTING.



Stepladders

Stepladders

These top-of-the-line heavyweight stepladders are made for heavy work in wood, fiberglass or aluminum. The protective rail shields and stronger side rails reduce the risk of cracking, so they're safer to use. A center pull spreader not only adds additional support, but makes setting-up and taking down much easier. The top caps are extra tough so they can withstand impacts and severe temperature changes without cracking.

Part Number	Description
6204	4 ft Step 1A/3000# Fiber
6206	6 ft Step 1A/3000# Fiber
6208	8 ft Step 1A/3000# Fiber

Floor Protection

Clean Mat

Clean Mat provides a unique, easy to use, cost-effective solution for capturing dirt before it is tracked in. Comprised of 30 layers of adhesive-coated film that effectively removes dirt from shoes. When the exposed layer is completely used, simply peel it off to expose a clean layer.

Part Number	Description
CM2436W4	24" x 36" - 4 pads

Carpet Mask

- Roll it on, stays in place
- Easy to use and to move
- Clear, tough, 2-mil. non-skid surface
- Temporary protection, up to 30 days
- Great for hallways and stairs
- Use on all types of synthetic carpets
- Tear and puncture resistant

Part Number	Description	Part Number	Description
CS24200L	24" x 200'	CS36250	36" x 250'
CS24500	24" x 500'	CS365000	36" x 500'
CS24000	24" x 1000'	CS361000	36" x 1000'
CS30200	30" x 200'	CS48500	48" x 500'
		CS481000	48" x 1000'



CLEAN STEP

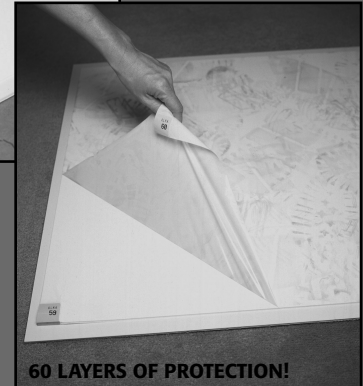

60 LAYERS OF PROTECTION!

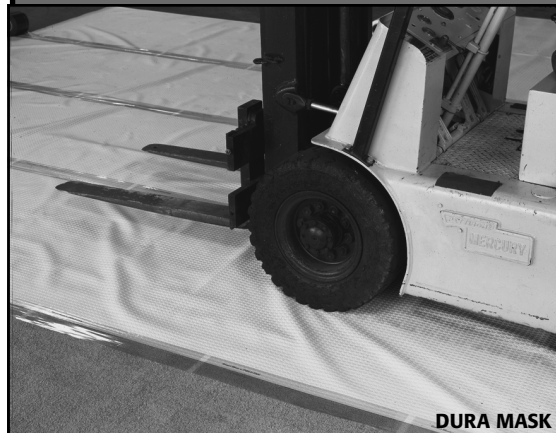

DURA MASK



CARPET MASK

Questions? Answers at...
(866) CED-ELEV • (866) 233-3538
www.cedelevator.com



FLOOR SHIELD



APPLICATOR

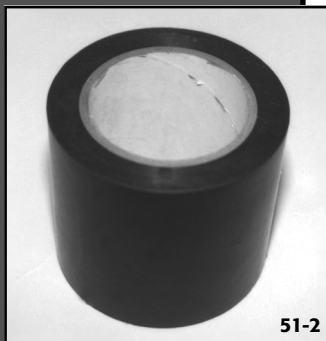
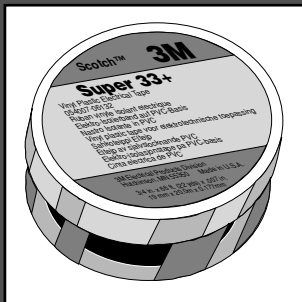

51-2

Floor Protection & Tapes

Floor Shield

- Specially formulated self-adhesive poly runner
- Durable protection
- Resistant to tearing and scuffing
- Ideal for countertops
- Protects hard surfaces such as linoleum, ceramic tile, cultured marble, etc.
- Temporary protection, up to 30 days

Part Number	Description	Part Number	Description
FS2450C	24" x 50'	FS36250	36"x250'
FS24200L	24" x 200'	FS36500	36"x500'
FS24500	24" x 500'		

Applicators

- Fast and easy for large areas of carpet
- Durable, heavy duty construction
- Saves time and labor
- Fits 200' and 1000' rolls in both widths

Part Number/Applicator Size

A21/21"; A2436/24", 30", 36"; A3660

Tapes: Friction, Rubber & Electrical

[UL listed, CSA Certified]

Part Number	Size	Type	Standard Packaging
1755	3/4" x 60'	Friction	1
2150	3/4" x 22'	Rubber	1
1700	3/4" x 60'	Electrical	10
33 (black)	3/4" x 66'	Electrical	10
35*	3/4" x 66'	Electrical	10

*Specify color

All-Weather 20-Mil Tape

Part Number	Description
51-2	20-mil Black Pressure Sensitive (2"x100')
51-4	20-mil Black Pressure Sensitive (4"x100')

Questions? Answers at...
(866) CED-ELEV • (866) 233-3538
www.cedlevator.com

Keyswitches

Function	Halo designations/locations			Keypulls			Survivor® Part Number			Designer™ Halo Only*	Classic™ Halo Only*	Survivor/Plus® Halo Only*	Key only	Key Code	Base Contacts	Config.
	12:00	3:00	6:00	9:00	12:00	3:00	6:00	9:00	Complete Keyswitch							
Car Call	Off	On	Up		X	M			AS468K06	AS468A115	A449B113	AS480B313	Custom	MAxx	4	DPDT
	Off	On	Down		X	M			AS468K07	AS468A115	A449B114	AS480B314	Custom	MAxx	4	DPDT
Fire Service (Hall)	Off	On	Up		X	M			AS468K15	AS468A113	A449B119	-	AKC0052A	AE102	4	DPDT
	Off	On	Down		X	M			AS468K11	AS468A205	A449B117	-	AKC0052A	AE102	4	DPDT
2000 Code (Optional Halo)	Off	On	Up		X	M			AS468K16	AS468A113	A449B114	-	Custom	MAxx	4	DPDT
	Off	On	Down		X	M			AS468K18	AS468A305	A449B117	-	AKC0052A	AE102	4	SPDT
2000 Code Fire Control	Off	On	Fire Service	Bypass	X	X	0		AS468K01	AS468A101	A449R181	AS480R381	AKC0054A	WD01	4	SP3T
	Off	On	Fire Recall	Bypass	X	X	0		AS468K09	AS468A101	A449R189	AS480R389	AKC0054A	WD01	4	SP3T
Panel Control	Off	On	Fire Service	Bypass	X	X	0		AS468K14	AS468A202	A449R181	-	AKC0054A	WD01	4	SP3T
	Off	On	Fire Service	Bypass	X	X	0		AS468K30	AS468A218	A449R181	AS480R381	AKC0056	H341	6	SP3T
2000 Code Fire Control	Off	On	Fire Service	Reset	X	X	0		AS469K14	AS469A17	A449R187	AS480R387	AKC0054A	WD01	2	SPDT
	Off	On	Fire Service	Reset	X	X	0		AS469K04	AS469A17	A449R182	AS480R382	AKC0054A	WD01	2	SPDT
2000 Code Fire Control	Off	On	Fire Recall	Reset	X	X	0		AS468K39	AS468A101	HRR0192	HRR0192V	AKC0054A	WD01	4	SP3T
	Off	On	Fire Recall	Reset	X	X	0		AS469K14	AS469A17	HRR0194	HRR0194V	AKC0054A	WD01	4	SP3T
2000 Code Fire Control	Off	On	Fire Recall	Fire Recall	X	X			AS469K14	AS469A17	HRR0187	HRR0187V	AKC0054A	WD01	6	SPDT
	Off	On	Fire Recall	Fire Recall	X	X			AS469K14	AS469A17	HRR0187	HRR0187V	AKC0054A	WD01	6	SPDT

Keypulls Legend: X = Keypull at that location 0 = No keypull -- = No function M = Momentary contact/spring return

Notes:

Blank Keyswitch Halos:

A450H4B, Survivor, black, 1/8" h
AS472-12B, Designer, black, 1/8" h

A450H4R, Survivor, red, 1/8" h
AS472-12R, Designer, red, 1/8" h

Adams Keyswitches

All Adams keyswitches use our Survivor base and are built with tough Lexan® housings. Choose from 2-, 3-, and 4-position configurations. 2-position switches are rated B300, Q300. All locks are 5-disk tumbler type. Key movement is 12:00/3:00 for 2-pull models; 9:00/12:00/3:00 for 3-pull models; and 6:00/9:00/12:00/3:00 for 4-pull keyswitches.

Keyswitches are available in 1/8" or 1/4" high halos. Order a complete assembly, halo only, base only, keyswitch only, or replacement key. Keyswitches can also be ordered in bronze or stainless cylinders. Keyswitches come with 2-, 4-, or 6-contact bases.

Order the switch and halo style from the table. For a switch not listed, please call CED.

NOTE: All keyswitches listed have 1/8"- high halos. Call for 1/4"-high halos (necessary for swing return stations).

Ordering Keyswitches

- Choose the function and halo legend** that matches the service configuration you need.
- Select halo style you need:** Survivor, Designer, Classic, or Survivor/PLUS.
- For complete keyswitch assembly:** Order "Switch only" and the halo you need from the appropriate "halo only" style column. [For a complete Survivor keyswitch, order from "Complete keyswitch" column; complete keyswitch includes a Survivor-style halo.]
- Stainless or bronze:** Complete keyswitch part numbers listed are for stainless. To order bronze switches, substitute a "J" for the "K" in the complete-keyswitch part number. For example, for a bronze Survivor assembly of keyswitch number **AS468K01** Fire Service, you would order complete-keyswitch part number **AS468J01**. [To order same switch with a **Classic** halo, order **AS468A101** (switch only) **PLUS AS480B319** (Classic halo only) for stainless; use switch-only part no. **AS468B101** for bronze.]
- Length of Base:** 2 contacts 1.875" deep, 4 contacts 2.375" deep, 6 contacts 3.000" deep.

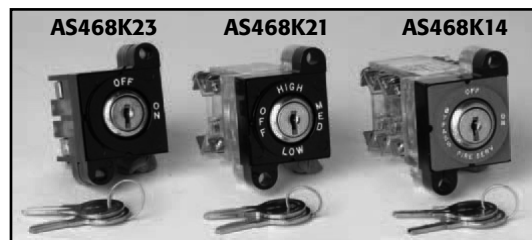

Questions? Answers at...
(866) CED-ELEV • (866) 233-3538
www.cedlevator.com

GENERAL PURPOSE

Keyswitches

Function	Halo designations/locations			Keypulls			Survivor Part Number			Designer TM Halo Only*	ClassiC TM Halo Only*	Survivor/Plus SM Halo only*	Key only	Key Code	Base Contacts	Config	
	12:00	3:00	6:00	9:00	12:00	3:00	6:00	9:00	Complete Keyswitch								Switch Only
Fire Service (Car)	Hold	On	X	Off	X	X	X	AS468K05	AS468A201	A449R186	HBD0186R	AS480R386	A448R186	AKC0054A	WD01	4	SP3T
	Hold	On	X	Off	X	X	X	AS468K25	AS468A116	A449R186	HBD0186R			AKC0054A	WD01	4	*
	Hold	On	X	Off	X	X	X	AS468K13	AS468A102	A449R186	HBD0186R			AKC0054A	WD01	6	SP3T
Phase II	Hold	On	X	Off	X	X	X	AS468K29	AS468A123	A449R186	HBD0186R	AS480R386	A448R186		H341	6	SP3T
	Off	On	0	Off	X	0	0	AS469K01	AS469A02	A449R182	HBD0182R			AKC0054A	WD01	2	SPDT
2000 Code (Optional/Halo)	Hold	On	0	Off	X	0	0	AS469K20	AS469A02	A449R187	HBD0187R			AKC0054A	WD01	2	SPDT
	Hold	On	0	Off	X	0	0	AS468K32	AS468A149	HRR0190			HRR0190V	AKC0054A	WD01	4	SP3T
Fan	Off	On	X	Off	X	X	X			HRR0195							
	Off	On	X	Off	X	X	X	AS469K12	AS469A05A	A449B109	HBD0109W	AS480B309	A448B109	AKC0051	MM101	2	SPDT
	High	Med	X	Off	X	X	X	AS468K21	AS468A207	A449B123	HBD0123W	AS480B323	A448B123	AKC0051	MM101	4	*
Fan/Light	High	Low	X	Off	X	X	X	AS468K02	AS468A104	A449B110	HBD0110W	AS480B310	A448B110	AKC0051	MM101	4	SPDT
	Light	Fan	X	Off	X	X	X	AS468K03	AS468A104	A449B112	HBD0112W	AS480B312	A448B112	AKC0051	MM101	4	SPDT
	Light	High	X	Off	X	X	X	AS468K20	AS468A207	A449B122	HBD0122W	AS480B322	A448B122	AKC0051	MM101	4	*
Photo Eye	Off	On	X	Off	X	X	X	AS469K10	AS469A05A	A449B111	HBD0111W	AS480B311	A448B111	AKC0051	MM101	2	SPST
	Off	On	X	Off	X	X	X	AS469K07	AS469A05	A449B104	HBD0104W	AS480B304	A448B104	AKC0051	MM101	2	SPDT
	Off	On	X	Off	X	X	X	AS469K08	AS469A05	A449B105	HBD0105W	AS480B305	A448B105	AKC0051	MM101	2	SPDT
Motor/Generator	Off	On	X	Off	X	X	X	AS469K09	AS469A05	A449B106	HBD0106W	AS480B306	A448B106	AKC0051	MM101	2	SPDT
	Off	On	X	Off	X	X	X	AS469K15	AS469A05	A449B101	HBD0101W	AS480B301	A448B101	AKC0051	MM101	2	SPDT
	On	Start	M	Off	X	M	X	AS468K19	AS468A111	A449B121	HBD0121W	AS480B321	A448B121	AKC0051	MM101	6	*
Off/On	Off	On	X	Start	X	M	X	AS468K22	AS468A212	A449B102	HBD0102W	AS480B302	A448B102	AKC0051	MM101	4	*
	Off	On	X	Start	X	M	X	AS468K22	AS468A109	A449B118	HBD0118W	AS480B318	A448B118	AKC-0051	MM101	4	DPDT
	Off	On	X	Start	X	M	X	AS468K23	AS468A209	A449B118	HBD0118W			AKC-0051	MM101	4	DPDT
Emergency	Off	On	X	Emer. Service	X	0	0	AS469K02	AS469A07	A449R184	HBD0184R	AS480R384	A448R184	AKC0052A	AE102	2	SPDT
	Off	On	X	Emer. Power	X	X	X	AS469K16	AS469A05	A449R183	HBD0183R	AS480R383	A448R183	AKC0051	MM101	2	SPDT
	Run	Stop	X	Code Blue	X	X	X	AS469K21	AS469A04C	A449R188	HBD0188R	AS480R388	A448R188 (Blk)	AKC0052A	AE102	2	DPST
Service	Run	Stop	X	Code Blue	X	X	X	AS468K26	AS468A409	A449R188	HBD0188R		A448R190 (Red)	AKC0052A	AE102	4	DPDT
	Off	On	X	Code Blue	X	M*	X	AS468K28	AS468A113	HBR0150				AKC0052A	AE102	4	DPDT
	Run	Stop	X	Hosp. Service	X	X	X	AS468K31					AS458-10*	AKC0052A	AE102	4	DPDT
Access	Off	On	X	Ind. Service	X	0	0	AS469K03	AS469A07	A449R185	HBD0185R	AS480R385	A448R185	AKC0052A	AE102	2	SPDT
	Off	On	X	Attendant	X	X	X	AS469K05	AS469A05	A449B103	HBD0103W	AS480B303	A448B103	AKC0051	MM101	2	SPDT
	Off	On	X	Access	X	X	X	AS469K06	AS469A05	A449B107	HBD0107W	AS480B307	A448B107	AKC0051	MM101	2	SPDT
Inspection	Up	On	X	Access	X	M	M	AS468K04	AS468A103	A449B115	HBD0115W	AS480B315	A448B115	AKC0053	GG101	6	*
	Up	On	X	Access	X	M	M	AS468K12	AS468A114	A449B115	HBD0115W			AKC0053	GG101	4	*
	Off	On	X	Inspection	X	X	X	AS469K22	AS469A04	A449B128	HBD0128W	AS480B328	A448B128	AKC0053	GG101	2	SPDT
Floor Disconnect	Off	On	X	Inspection	X	X	X	AS469K13	AS469A04	A449B116	HBD0116W	AS480B316	A448B116	AKC0053	GG101	4	DPDT
	Off	On	X	Inspection	X	X	X	AS468K24	AS468A309	A449B116	HBD0116W			AKC0053	GG101	4	DPDT
	Off	On	X	Inspection	X	X	X	AS469K17	AS469A15	A449B118	HBD0118W			AKC0052A	AE102	2	SPDT
Light	Off	On	X	Inspection	X	X	X	AS469K18	AS469A13	A449B118	HBD0118W			(Unique)	Mxxx	2	SPDT
	Off	On	X	Inspection	X	X	X	AS469K19	AS469A05	A449B118	HBD0118W			AKC0051	MM101	2	SPDT
	Off	On	X	Inspection	X	X	X	AS469K11	AS469A05A	A449B108	HBD0108W	AS480B308	A448B108	AKC0051	MM101	2	SPST

*Separate contacts

Keypulls Legend: X = Keypull at that location 0 = No keypull -- = No function M = Momentary contact/spring return

Notes:
 2-Contact Base=1.875" d; 4-Contact Base=2.375" d; 6-Contact Base=3.0" d
 Halo for Code Blue: HBR0150-Blue Halo Survivor Style HBR0190-Red Halo
 RUN/STOP Vandal-resistant halos: A448R188 = black halo A448R190 = red halo
 AS458-10 = #4 stainless, engraved w/red fill; fits into coined pocket

Questions? Answers at...
 (866) CED-ELEV • (866) 233-3538
 www.cedlevator.com

LEDs for Adams Fixtures

Survivor® Buttons & Bases

Part Number	Description
AS451A	Contact Base with Lamp Holder (2NO)
AS451A-02	Contact Base for LEDs (2NO)
AS451C	Contact base with Lamp Holder (1NO/1NC)
AS458C2	Illuminated Button & Halo (no base)
AS458C6	Survivor®PLUS Complete Button Assembly, Illuminated, Stainless Steel (1NO/NC)

Position Indicator Lens Cap

Clear Lens Cap for Position Indicator Lens 146A560H05.

Part Number **W454BC1**

LEDs for Survivor Base

These LEDs will work with Adams Survivor® base jewel or button including Survivor, Designer, Classic, Homelift and Survivor Plus (Sold in 10-packs; base sold separately, see page 1.19).

Part Numbers		
Red	Amber	Voltage AC/DC
A494LR0*	—	Phone*
A494LR1	A494LW1	6
A494LR2	A494LW2	12
A494LR3	A494LW3	24/28
A494LR4	A494LW4	48/60
A494LR5	A494LW5	120
—	A494LW7	240

7-jewel LEDs for A474IL

Triangular Hall Lanterns

Part Numbers			
Green	Red	Amber	Voltage AC/DC
A495I1G2	A495I1R2	A495I1A2	24
A495I2G2	A495I2R2	A495I2A2	48
A495I3G2	A495I3R2	A495I3A2	60
A495I4G2	A495I4R2	A495I4A2	120
A495I5G2	A495I5R2	A495I5A2	240

LEDs for A474FL Hall Lanterns

(3-jewel units to replace existing A495D-series)

Part Numbers			
Green	Red	Amber	Voltage AC/DC
A495D0G	A495D0R	A495D0W	12
A495D1G	A495D1R	A495D1W	24/28
A495D2G	A495D2R	A495D2W	48
A495D3G	A495D3R	A495D3W	60
A495D4G	A495D4R	A495D4W	120

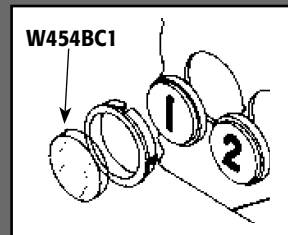
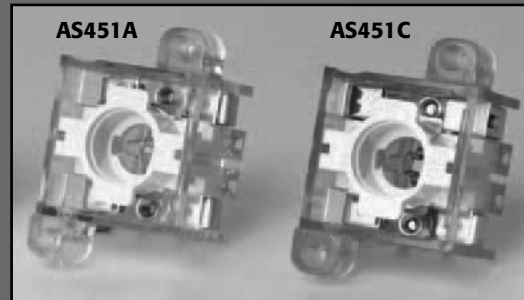

AS451A-02
Survivor base for LED illumination

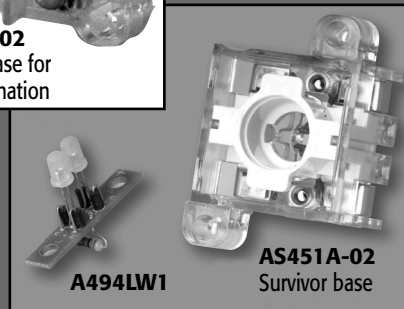

A494LW1

AS451A-02
Survivor base

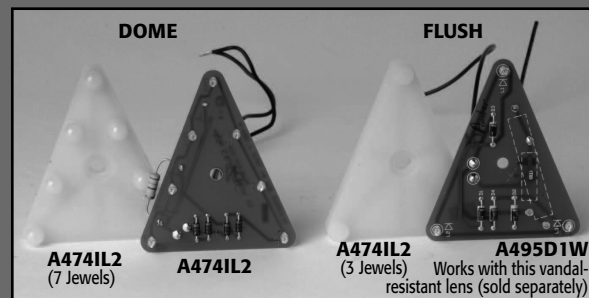

A474IL2
(7 Jewels)

A474IL2

A474IL2
(3 Jewels)

A495D1W
Works with this vandal-resistant lens (sold separately)

Questions? Answers at...
(866) CED-ELEV • (866) 233-3538
www.cedlevator.com

Elsco Roller Guides



Elsco™ Roller Guides
CED offers a complete line of elsco roller guides to meet the most demanding performance standards in the industry

Part Number	Recommended Application
EA18300	High-speed passenger and heavy-duty freight elevator six-wheel guide with adjustable stops.
EB02100	Moderate-speed and moderate-capacity elevator with adjustable stops.
EC18400	A smaller version of the EA18300. Designed for many elevators and counterweights.
ED02000	For low-speed & low-load elevators and moderate-speed counterweights.

Part Number	Number of Wheels	Wheel Diameter	Cab Capacity			Speed		ELSCO Part Number
			Passenger	Freight	Counterweight	Passenger/Freight	Counterweight	
EA18300	6	6"	8000lbs.	12,000lbs.**	N/A	1500ft./min.	N/A	Model A
EB02100	3	6"	4500lbs.	6000lbs.**	8000lbs.	700ft./min.	1400ft./min.	Model B
EC18400	6	3¼"	2500lbs.	N/A	8000lbs.	400ft./min.	800ft./min.	Model C
ED02000	3	3¼"	2000lbs.	2000lbs.	4000lbs.	250ft./min.	800ft./min.	Model D

**When modified with Adams SPx80™ Quiet Poly rollers (sold separately).



Replacement Guide Wheels

Part Number	Diam.	Width Face	Bore	Tire Material	For use on
EA18359	6"	1¼" ½"	0.7874"	SPx80 Quiet Poly	Model A
EC18405	3¼"	¾" ½"	0.4724"	SPx80 Quiet Poly	Models C&D

*Additional sizes listed on next page

Rollers ElSCO

Elsco™ Descriptions:

Neoprene - roller wheels are the ELSCO standard, recommended for most passenger applications. Optimized to provide premium ride quality and low noise, only genuine ELSCO neoprene wheels provide the damping characteristics essential to ride quality, and only genuine ELSCO neoprene wheels are engineered with high "memory" characteristics that prevent flat spots.

Green Poly -roller wheels offer a compromise solution where challenging static loading conditions are expected, yet ride quality remains a priority. ELSCO green poly rollers are compounded to a medium hardness that is able to handle high static loads, but retains some ride quality benefits. Green poly rollers are most commonly recommended in hospital cars and high speed passenger/service elevators.

(Recommended also for passenger elevators in which the rollers need to have more preload in order to center the elevator or counterweight)

Red Poly - roller wheels are typically recommended for extreme freight applications. Using a very hard tread compound, these rollers are engineered to withstand the high static loading conditions typically encountered in freight elevators and severely unbalanced cars. This resistance to deflection comes at the expense of ride quality and noise suppression; these wheels are therefore not commonly recommended for passenger elevators.

Slide Guides – ELSCO slide guides provide ride quality in a cost-effective package for those applications that do not allow for the installation of roller guides. ELSCO slide guides are spring loaded with adjustable stops and Molybdenum Disulfide-Filled Nylon inserts, which allows for the rail to not have to be lubricated. There are four options. The SA-15 and SA-8 are for elevator cars and the SC-8 and SD-8 are for counterweights. The SA-15 and SA-8 can be modified for 18.5# rail.

Flex-Mount Adapter Plates – ELSCO's solution to mounting ELSCO guides onto pre-existing hole patterns. The patented adapter plates are universal and work with most pre-existing bolt patterns. There are two sizes, one for the car and one for the counterweight. There is a seismic version available. Be sure to note the rail size when ordering the seismic version.



CED—ELSCO PRODUCT GUIDE

FLEX-MOUNT ADAPTER PLATE



EA07100 CAR
EC07100 COUNTERWEIGHT
*FOR SEISMIC VERSION, SPECIFY RAIL SIZE

SLIDE GUIDES

SA-15
EF04114



SC-8
EF04116



SA-8
EF04112

SD-8
EF04118

SLIDE GUIDE INSERTS

EF04125 Insert for SA-8 and SC-8

EF04127 Insert for SA-15

EF04129 Insert for SD-8

EF04137 Insert for SA-15, for 3/4" rail

EF04139 Insert for SA-8, for 3/4" rail

COVER PLATES

Part No	Description
EA18333	Cover Plate Kit - Model A
EB02123	Cover Plate Kit - Model B
EC18403	Cover Plate Kit - Model C
ED02013	Cover Plate Kit - Model D
EE02214	Cover Plate Kit - Model E
EY02096	Cover Plate Kit - Express 3
EX02009	Cover Plate Kit - Express 6

SPARE ROLLERS

Part No	Description
EB06015	Models A & B w/ 15# Rail
EA18347	6" dia. red poly roller-side
EA18348	6" dia. red poly roller-face
EA18381	6" dia. green poly roller-side
EA18382	6" dia. green poly roller-face
EC18441	3 1/4" dia. red poly roller
EC18446	3 1/4" dia. green poly roller
EC18446	3 1/4" dia. green poly roller
EE02203	3 1/4" dia. neoprene roller
EE02203	3 1/4" dia. neoprene roller
EE02209	3 1/4" dia. red poly roller
EE02219	3 1/4" dia. green poly roller
EE02219	3 1/4" dia. green poly roller
EX02002	10" dia. neoprene roller
EX02003	10" dia. red poly roller

SEISMIC PLATES

Part No	Description
EB06015	Models A & B w/ 15# Rail
EB06018	Models A & B w/ 18 1/2# Rail
ED06008	Models C & D w/ 8# rail
ED06015	Models C & D w/ 15# rail
EE06008	Model E w/ 8# Rail
EE06015	Model E w/ 15# Rail

Questions? Answers at...
(866) CED-ELEV • (866) 233-3538
www.cedlevator.com

Rollers Esco

Passenger Elevators Platform dimensions up to 10'-0" wide by 8'-0" deep (305 cm wide by 244 cm deep)

	Elevator Speed Range							
	Up to 500 fpm (2.5 m/s)		600-800 fpm (3.0-4.0 m/s)		1,000-1,200 fpm (5.0-6.0 m/s)		1,400 fpm (7.0 m/s) and faster	
	Car	Counterweight	Car	Counterweight	Car	Counterweight	Car	Counterweight
< 3,000 lbs. (1,350 kg.)	Model B	Model D	Model A	Model C	Express 3	Model C	Express 6	Model A
3,500 lbs. (1,600 kg.)	Model B	Model D	Model A	Model C	Express 3	Model C	Express 6	Model A
4,000 lbs. (1,800 kg.)	Model B	Model D	Model A	Model C	Express 3	Model C	Express 6	Model A
4,500 lbs. (2,050 kg.)	Model A	Model C	Model A	Model C	Express 3	Model C	Express 6	Model A
5,000 lbs. (2,300 kg.)	Model A	Model C with adjustable stops	Model A	Model C with adjustable stops	Express 3	Model C	Express 6	Model A
6,000 lbs. (2,700 kg.)	Model A	Model C with adjustable stops	Model A	Model C with adjustable stops	Express 6	Model A	Express 6	Model A
7,000 lbs. (3,200 kg.)	Model A	Model C with adjustable stops	Model A	Model C with adjustable stops	Elevators in this high speed and capacity range often involve additional complexities that you should discuss with an ELSCO guide specialist previous to ordering.			
	Up to 300 fpm (1.5 m/s)							
	Car	Counterweight						
8,000-10,000 lbs. (3,600-4,500 kg.)	Model A with red polyurethane rollers	Model C with red polyurethane rollers & adjustable stops						

Hospital Elevators Platform dimensions up to 6'-0" wide by 10'-0" deep (183 cm wide by 305 cm deep)

	Elevator Speed Range							
	Up to 250 fpm (1.25 m/s)		300-500 fpm (1.5-2.5 m/s)		600-800 fpm (3.0-4.0 m/s)		1,000-1,200 fpm (5.0-6.0 m/s)	
	Car	Counterweight	Car	Counterweight	Car	Counterweight	Car	Counterweight
< 3,000 lbs. (1,350 kg.)	Model B	Model D	Model B	Model D	Model A	Model C	Express 3	Model C
3,500 lbs. (1,600 kg.)	Model B	Model D	Model A	Model D	Model A	Model C	Express 3	Model C
4,000 lbs. (1,800 kg.)	Model A	Model D	Model A	Model D	Model A	Model C	Express 3	Model C
4,500 lbs. (2,050 kg.)	Model A	Model C	Model A	Model C	Model A	Model C	Elevators in this high speed and capacity range often involve additional complexities that you should discuss with an ELSCO guide specialist previous to ordering.	
5,000 lbs. (2,300 kg.)	Model A	Model C with adjustable stops	Model A	Model C with adjustable stops	Model A	Model C with adjustable stops		
6,000 lbs. (2,700 kg.)	Model A with green polyurethane rollers	Model C with green polyurethane rollers & adjustable stops	Model A with green polyurethane rollers	Model C with green polyurethane rollers & adjustable stops				
7,000 lbs. (3,200 kg.)	Model A with green polyurethane rollers	Model C with green polyurethane rollers & adjustable stops	Model A with green polyurethane rollers	Model C with green polyurethane rollers & adjustable stops				
8,000-10,000 lbs. (3,600-4,500 kg.)	Model A with red polyurethane rollers	Model C with red polyurethane rollers & adjustable stops						

Service and Freight Elevators Platform dimensions up to 10'-0" wide by 8'-0" deep (305 cm wide by 244 cm deep)

	Elevator Speed Range							
	Up to 250 fpm (1.25 m/s)		300-500 fpm (1.5-2.5 m/s)		600-800 fpm (3.0-4.0 m/s)		1,000-1,200 fpm (5.0-6.0 m/s)	
	Car	Counterweight	Car	Counterweight	Car	Counterweight	Car	Counterweight
< 3,000 lbs. (1,350 kg.)	Model B	Model D	Model B	Model D	Model A	Model C	Express 3	Model C
3,500 lbs. (1,600 kg.)	Model B	Model D	Model A	Model D	Model A	Model C	Express 3	Model C
4,000 lbs. (1,800 kg.)	Model A	Model D	Model A	Model C	Model A	Model C	Express 3	Model C
4,500 lbs. (2,050 kg.)	Model A	Model C	Model A	Model C	Model A	Model C	Elevators in this high speed and capacity range often involve additional complexities that you should discuss with an ELSCO guide specialist previous to ordering.	
5,000 lbs. (2,300 kg.)	Model A	Model C with adjustable stops	Model A	Model C with adjustable stops	Model A	Model C with adjustable stops		
6,000 lbs. (2,700 kg.)	Model A with green polyurethane rollers	Model C with green polyurethane rollers & adjustable stops	Model A with green polyurethane rollers	Model C with green polyurethane rollers & adjustable stops				
8,000 lbs. (3,600 kg.)	Model A with green polyurethane rollers	Model C with green polyurethane rollers & adjustable stops	Model A with green polyurethane rollers	Model C with green polyurethane rollers & adjustable stops				
10,000 lbs. (4,500 kg.)	Model A with red polyurethane rollers	Model C with red polyurethane rollers & adjustable stops						

Questions? Answers at...
(866) CED-ELEV • (866) 233-3538
www.cedlevator.com

Miscellaneous

Astragal

Makes door closings quieter; seals out light between doors. Flexible black rubber, reversing astragal for $\frac{3}{8}$ "-wide groove; install one on door, and one on jamb or opposite door. Eight-foot lengths; easily cut to size at job site.

Part Number **A853L**

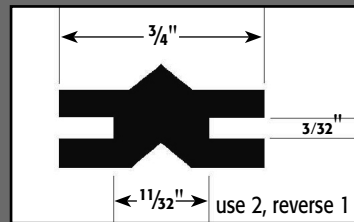

Burnishing & Polishing Tools

Brush Seating Cleaning Stones

Part Number	Dimensions (L W H)	Grade	Qty./box
A5612A2	4 $\frac{3}{4}$ " x 2" x 1 $\frac{1}{4}$ "	Med. Soft	1
A5612A6	4 $\frac{3}{4}$ " x $\frac{1}{2}$ " x $\frac{1}{4}$ "	Fine hard	4

Commutator Treating Kit

Packs into a convenient storage box everything you need for thorough commutator maintenance:

- 2 each: coarse, medium, finish and x-finish
- 4 firm/hard seating stones
- 1 stone holder
- 1 storage case

Part Number **A5613A1**

Commutator Kit Replacement stones (6/pkg.):

Part Number	Description
A5614A1	Coarse
A5614A2	Medium
A5614A3	Finish
A5614A4	X-Finish
A5614A5	Firm/Hard Seating

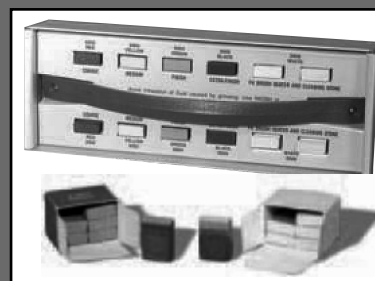
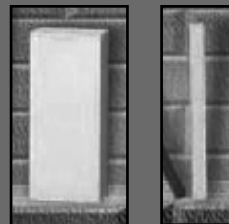

Contact Burnishing Tools

The easy way to polish contacts and remove any non-conductive residual material for safe and reliable operation.

Part Number	Dimensions (L x W x Thickness)	Per pack
A561B1	4" x $\frac{3}{16}$ " x 0.007"	10
A561B2	3 $\frac{5}{8}$ " x $\frac{1}{4}$ " x 0.010"	10

Diamond Spatula Kit

Use premium, long-lasting, non-residual diamond spatulas, the most popular, longest lasting, and in the long run, most economical tools.

Part Number	Description
A5616A4	3-piece spatula kit, includes one each: Coarse-grit spatula (green handle) Medium-grit spatula (red handle) Fine-grit spatula (blue handle, grit on one side only)

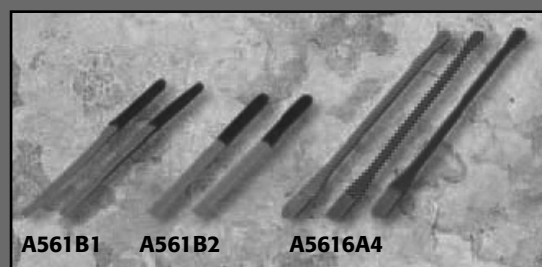

Size Selection

For brush seating, choose a stone with a width equal to, or slightly greater, than the width of the brush. For cleaning commutators, pick a stone about 3/4 the length of the commutator bar and as thick as will neatly fit between the brush riggings.

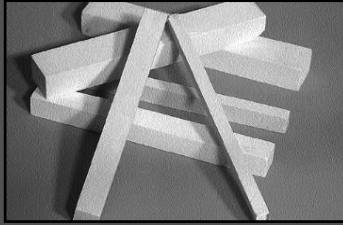

Part Number	Description
BRSRX01MS	BRUSH SEATING CLEANING STONE, 4-3/4" X 2" X 1-1/4"
BRSRX06MS	BRUSH SEATING CLEANING STONE, 4-3/4" X 1" X 1/2"
BRSRX08MS	BRUSH SEATING CLEANING STONE, 4-3/4" X 3/4" X 1/2"
BRSRX11FH	BRUSH SEATING CLEANING STONE, 4-3/4" X 3/4" X 1/4"
BRSRX12FH	BRUSH SEATING CLEANING STONE, 4-3/4" X 1/2" X 1/4"
BRSRX16MS	BRUSH CLEANING & SEATING STONE, MEDIUM SOFT GRADE, 4-3/4" x 1" x 1"
BRSRX18FH	BRUSH SEATING CLEANING STONE, 4-3/4" X 3/8" X 1/4"

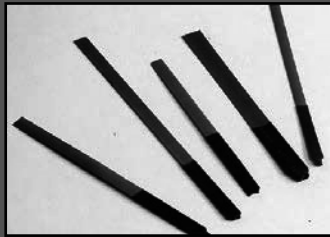

Part Number	Description
BURNX4	CONTACT BURNISHING TOOL, 12 PK, 3-1/2" LONG, 1/4" W x .011"

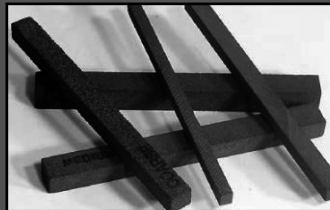

Part Number	Description
COMMMLS800	RESURFACING STONE, PENCIL TYPE, 6" X 3/8" X 1/4" (GRADE M)
COMMMLS840	RESURFACING STONE, PENCIL TYPE, 6" X 3/4" X 3/4" (GRADE P)
COMMMLS850F	RESURFACING STONE, PENCIL TYPE, 8" X 2" X 1" (FINE GRIT)
COMMMLS850M	RESURFACING STONE, PENCIL TYPE, 8" X 2" X 1" (MEDIUM GRIT)

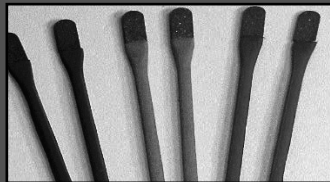

Part Number	Description
SPATX4000	DIAMOND D SPATULA, 5-5/8" L x 1/4" W, 7/8" HEAD, GREEN (COARSE)
SPATX4001	DIAMOND D SPATULA, 5-5/8" L x 1/4" W, 7/8" HEAD, RED (MEDIUM)
SPATX4003	DIAMOND D SPATULA KIT, 5-5/8" L x 1/4" W, 7/8" HEADS, (COARSE, MED & FINE)

Martindale Abrasives

Diamond D Brush Seaters

Commutators and slip ring brushes of any material can be easily and accurately seated with Diamond D Brush Seaters. Just hold the Brush Seater on the commutator close to the brush so the Brush Seater material will be carried under the brush. At the same time, press on the brush to increase pressure. Many commutators and slip-ring troubles are caused by poor contact with the brushes. This is particularly true when new brushes are installed along with old ones because if the new brushes do not make good contact, the current is forced through the other brushes. This overloads the other brushes causing pitting of the brush faces, loosening of brush shunts, burning of brush holders, and many other evils that result from sparking and heating.

Diamond D Contact Burnishers

These exceptional tools are designed to burnish and polish all types of contacts without removing virtually any precious metal. They leave no grit, no filings, no dust and no film that would start new carbon build-up. Diamond D Contact Burnishers perform superbly on all types of metal, including silver, gold, platinum, molybdenum and tungsten. We have designed them with just enough stiffness to apply the proper pressure to the contact face. Our contact burnishers are available either with plastic handles or in our handy Pocket Pen Holder. Proven by years and years of faithful field service, these tools have greatly extended the lives of millions of contacts.

Resurfacing Stones

These are unmounted stones (no handles). The smaller sizes are used for small motors and generators. The larger sizes are clamped in a lathe or portable grinder.

Diamond Spatulas

No product outperforms these Diamond Spatulas, when it comes to cleaning, polishing and burnishing contacts. Our spatulas consist of uniform diamond particles set in a special metal, then molded to a color coded nylon shaft. The diamond particles we use are such an effective abrasive that only minimum pressure is required on the contact, so very little metal is removed. The naturally irregular shapes of the particles also prevents clogging. The surface remains clean, insuring maximum efficiency.

Our nylon shaft gives you good flexibility for normally inaccessible areas, as well as permitting use of the spatula under power. All our Diamond Spatulas are approximately 5-5/8" long with a 1/4" wide by 7/8" diamond face.

Questions? Answers at...
 (866) CED-ELEV • (866) 233-3538
www.cedlevator.com

Martindale Abrasives

Commutator Treating Kit

You'll never find a more versatile tool than this one. The shape can be quickly changed to fit any job. Simply dip the tool in hot water for one minute, then bend the handle to suit your particular application. The holder and inserts are both non-conductive, so the tool is extremely safe to use. The exclusive hex nut and screw locking assembly permits replacement and locking of inserts, eliminating the chance of the stone working its way loose. With this versatile treating kit you'll find it easy to keep small commutators operating at peak efficiency.

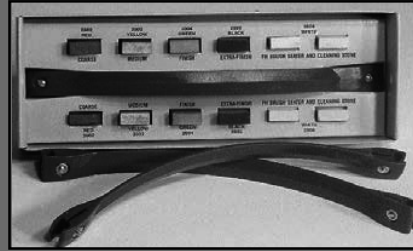

Part Number	Description
DIAMX2000	MARTINDALE COMMUTATOR TREATING KIT, ALL GRADES OF STONES & HOLDER

Flexible Files

This unique product offers all of the traditional features of ordinary files — plus the flexibility you often need. Plastone flexible files are made of hard abrasive materials pressed into a flexible core. This enables you to bend or twist these tools any way you like to reach curved surfaces and otherwise hard-to-reach areas. Because they are non-conductive, these special files are popular for dressing automotive, electrical and electronic contacts.

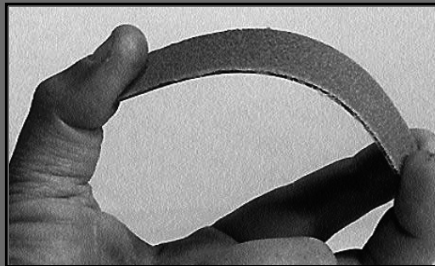

Many other uses can be found for these inexpensive files, wherever fine finishing of metals is required. They are impervious to oil and water; accumulations of grease can be washed from them with cleaning solvents or soap and water.

Part Number	Description
FLXFX1002	FLEXIBLE FILE, 12 PK, 1/4" W x 4-3/4" L x .020" T, 240 GRIT (EXTRA-FINE)
FLXFX1004	FLEXIBLE FILE, 12 PK, 3/8" W x 4-3/4" L x .020" T, 240 GRIT (EXTRA-FINE)
FLXFX1044	FLEXIBLE FILE, 12 PK, 3/8" W x 4-3/4" L x .025" T, 120 GRIT (MEDIUM)
FLXFX1045	FLEXIBLE FILE, 12 PK, 1/2" W x 4-3/4" L x .025" T, 180 GRIT (FINE)
FLXFX3004	FLEXIBLE FILE, 12 PK, 3/8" W x 4-3/4" L x .040" T, 180 GRIT (FINE)
FLXFX3033	FLEXIBLE FILE, 12 PK, 3/8" W x 4-3/4" L x .040" T, 80 GRIT (COARSE)
FLXFX3045	FLEXIBLE FILE, 12 PK, 1/2" W x 4-3/4" L x .040" T, 180 GRIT (FINE)

Rubrite flexible abrasive cleaning stones

Rubrite flexible abrasive cleaning stones are excellent for removing surface imperfections from any metal. Mildly abrasive, they do only enough cutting to produce a high polish and fine finish. They are slow-wearing, non-loading, and will not gum or dust. Recommended in commutator maintenance for periodic cleanup of surface, or for polishing the commutator after grinding with Diamond D commstones. They can also be recommended to provide a smooth, clean finish on

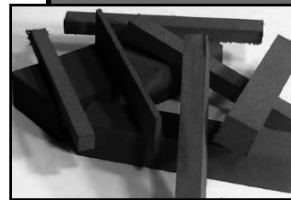

machined parts, etc. This type can be used for hundreds of jobs including metal cleaning, commutator burnishing and

Part Number	Description
RUBBX6250	RUBRITE FLEXIBLE ABRASIVE, 3/8" X 3/8" X 5"
RUBBX6252	RUBRITE FLEXIBLE ABRASIVE, 3/8" X 5/8" X 5"
RUBBX6256	RUBRITE FLEXIBLE ABRASIVE, 1/2" X 1" X 5"
RUBBX6259	RUBRITE FLEXIBLE ABRASIVE, 5/8" X 1" X 5"
RUBBX6262	RUBRITE FLEXIBLE ABRASIVE, 1" X 1" X 5"
RUBBX6271	RUBRITE FLEXIBLE ABRASIVE, 1/8" X 1" X 5"



CETGO24-BFI

Mini Buzzer

24VAC Mini
Nudging Buzzer,
Part Number **A924C**



X911X3

A911X6

A911X1

Miscellaneous

Chimes, Electronic, with Timer

Replace the harsh, mechanical sound of floor landing bells with our pleasant-sounding electronic chime. Order as a retrofit unit, or specify it next time you install a hall or travelling lantern. Timer sounds once for "up" and twice for "down." All models include pressure-sensitive mounting pads and helpful wiring diagram. Match your voltage range to the models listed at right.

Dimensions: 4"W x 2³/₈"H x 7⁸/₈"D

Part Number	Voltage/Description
-------------	---------------------

CH024	20/40 VAC/VDC
--------------	---------------

CETGO120-BFI	40/125 VAC/VDC
---------------------	----------------

CETGO024-BFS	20/40 VAC/VDC; chimes once in both directions (unless controller can send a 2-stroke signal for down).
---------------------	--

CETGO24-BFI	40/125 VAC/VDC; chimes once in both directions (unless controller can send a 2-stroke signal for down)
--------------------	--

NOTE: Adams electronic chimes are UL recognized.

Emergency Light Unit & Components

Restore worn or damaged emergency light units with these service ready components.

Part Number	Description
-------------	-------------

A911	Emergency light unit, complete.
-------------	---------------------------------

A911LL	Heavy-duty Lexan lens; 6 ³ / ₄ " x 2 ¹ / ₂ " (not shown)
---------------	--

A911X6	2 lamp sockets with wiring harness, bayonet type.
---------------	---

A911X3	Rechargeable battery, 6 volts; 3 ³ / ₄ " x 6" x 1 ¹ / ₂ "
---------------	---

A911X1	6V solid-state PCB with switch assembly, bracket, and wire leads; 5" x 5" x 2" deep.
---------------	--

A911AX	6V/240 Emergency light, PCB only.
---------------	-----------------------------------

A911X1A	6V/240 PCB with switch assembly.
----------------	----------------------------------

A480L30	Replacement lamp for emergency light unit; 10/pkg.
----------------	--

Miscellaneous

HatchLatch® Electronic Door Restrictor

Prevents Unsafe Elevator Cab Openings

Comes standard with all the material you need to protect one elevator, up to five floors. To protect more than 5 floors, order additional reflective tape.

Here's how it works:

Reflective Tape You position pieces of reflective tape in the hatchway inside the landing zone and on the door operator.

First Photoeye When the first of the two photoeyes sees the tape in the hoistway, it senses that the elevator is inside the landing zone.

Second Photoeye When the second photoeye sees the tape on the door operator, it picks up a solenoid-controlled plunger.

Plunger The plunger rises out of the way, clearing the door roller or blocking bracket as the door opens.

No Exit! Zone Between landing zones, the photoeye senses no tape reflection and the plunger holds its door-blocking position.

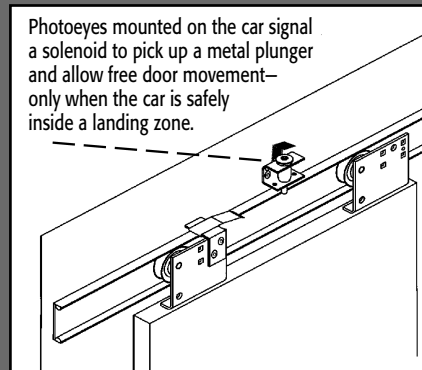

Part Number	Description
A835A4	EDR Assembly w/Box (includes battery)
A835R2	Reflective Tape, 2"x10' (for up to 75 floors)

Soft Stop "Anti-Chatter" Additive

This performance-improving fluid is a special friction modifier that enhances the flow characteristics of most hydraulic systems. It can relieve the "stick-slip" problem on noisy hydraulic cylinders. Not recommended for machines with common systems for hydraulic, transmission, and braking.



Part Number	Description
APO800QC	Adams Soft Stop Hydraulic Additive (32-oz. bottle, 12 quarts/case only)

Selector Tape Guide

Nylatron tape guide for W302 selector tape.
Part Number **W875**

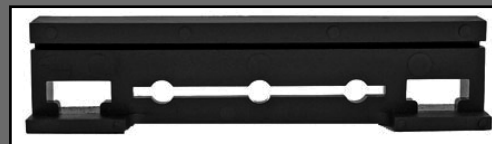

HOISTING EQUIPMENT & SUPPLIES

10

In this Section

Cable Climber	10.2
Wire Rope Climbers	
Tirak Wire Rope Climber	10.2
Power Climber Hoist	
Electric Capstan	
Power Hoist System	10.3
Power Winch	10.3
Wire Rope Sling	10.4
Polyester Rope	10.4
Wood Tackle Blocks	10.5
Wire Rope Blocks	10.5
Quick Release Clevis	10.6
Crosshead Clevis	10.6
Rail Block/Clevis	10.6
Chain & Anchor Shackles	10.6
Rail Hoisting Clevis	10.7
Rail Clamp	10.7

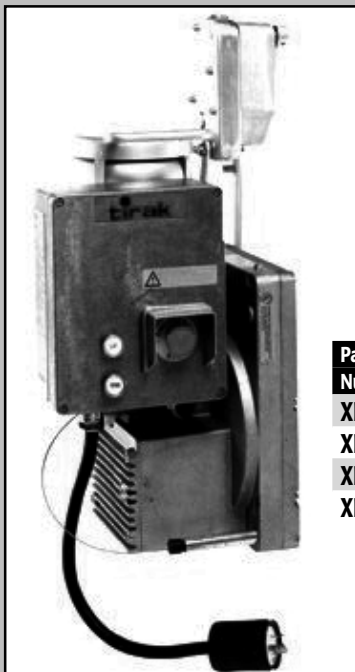

Part Number	Rated Load	Lifting Speed	Weight	Voltage	Phase	Amps	Breaking	
							Diam.	Strength
XE301A	700	35	77	220	1	10.5	5/16"	10,000lbs.
XE501P	1000	35	121	110/220	1	19.5/9.5	5/16"	10,000lbs.
XE701PBS	1500	35	123	220	1	12	5/16"	10,000lbs.
XE1020P	2200	35	123	220	3	18	5/16"	15,000lbs.

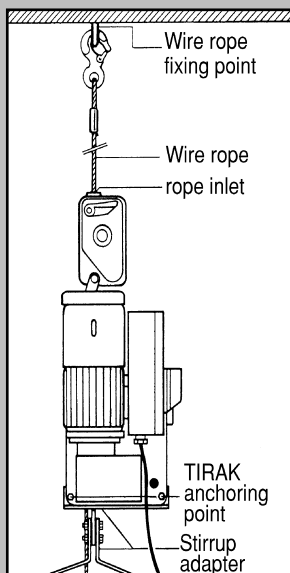

Part Number	Motor (hp/psi)	Capacity (lbs.)	Draw (amp)	Speed (ft./min.)	Weight (lbs.)	Dimensions (in. HxWxD)
PC3-1500E	208VAC, 60Hz, single phase	1500	9	35	101	23.5x14x12.75
PC3-1500E3	208VAC, 60Hz, 3 phase	1500	8	35	100	23.5x14x12.75
PC3-1000-110	110VAC, 60Hz, single phase	1000	14	>15	99	23.5x14x12.75

Wire Rope Climbers

Tirak Wire Rope Climber

1500 Lb Load Rating, 220v, 1 Phase

The Tirak motorized X- series hoist, safely lifts and lowers false cars, work cages and other man-riding equipment at a speed of 35 FPM. This compact, lightweight model weighs only 126 pounds and requires minimum maintenance. The travel height is limited only to the length of the wire rope and power cord.

Powerclimber® Hoist

Power Climber is a world leader in the manufacture of high quality wire rope climbers. The PC3 hoist series is an excellent product to use for powering False Cars, Go-Devils, Skip Hoists, etc. Power Climber offers the most advanced, reliable, affordable and easiest to use wire rope climber on the market.

- 1500 lbs. at 35 FPM
- 50% duty cycle
- Operates on 170-229 volt
- 8 amp, single-phase power, eliminating delays due to low current job site conditions
- Electrical components on one motherboard! Change the motherboard out to solve an electrical issue in less than 5 minutes.
- Works with just about any 5/16" wire rope
- Two carrying handles, one used to stand unit on the table for service
- Hour meter records running hours for better maintenance interval planning
- Built-in over speed device for use with second rope
- Nearly impossible to jam wire rope
- Low voltage indicator indicates proper voltage to unit, blinks at marginal voltage and goes out at voltage outside rated range
- Made in the U.S.A.

Questions? Answers at...

(866) CED-ELEV • (866) 233-3538
www.cedlevator.com

Power Hoists

Electric Capstan Power Hoist System

A most versatile, powerful, time saving tool. Can be used for hoisting rails and brackets, driving chain falls, pulling wire through conduit and a myriad of other chores. This lightweight power worker mounts just about anywhere, has 1,000 lb. capacity and runs on 120 volt single phase current. Hoist assembly comes complete with foot switch, angle mounting bracket, rail blocks and rope locking device. Items may be purchased separately.

Part Number **C417-6014**

120V Hoist Assembly includes:

#**C308-1170** (Capstan Hoist with Foot Control)

#**C417-6014** (Capstan Hoist Assembly)

#**C308-0856** (Rope Lock Device)

#**C308-0873** (Chain Puller Kit—optional)

Service and parts available.

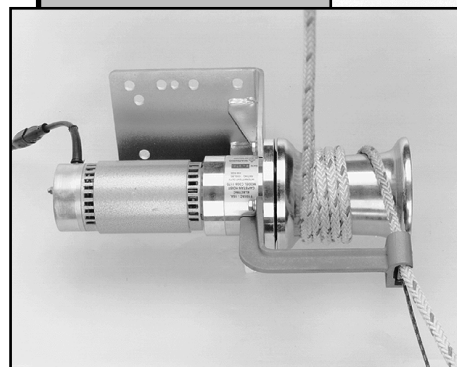
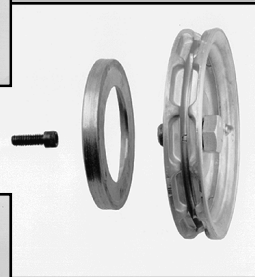

Power Winch

Lift 1200 pounds in a tight machine room! This small (approximately 21"x8"x8"), lightweight (40 lbs.), powerful (400 to 1200 lbs. pull), high quality winch and accessories are a must for your tool inventory. They are ideally suited for service work such as hoisting controllers, motors, gearcases, etc. to and from machine rooms. Call for a brochure or quotation.

Series	Voltage	Switch	Model
1200	115	MO	12-15 RMO
1200	230	MO	12-30 RMO

Other sizes are available.



Hoisting Equipment

Full line of hoisting equipment to meet any job requirements. Winches, cranes, hoists, manual or power assisted and associated equipment. Please call for quote.

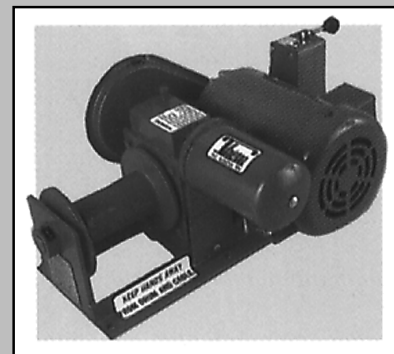
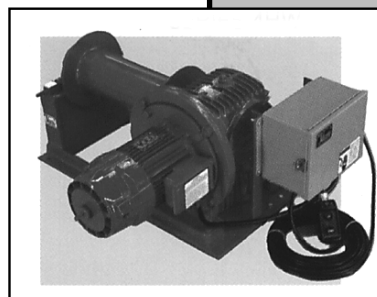

Questions? Answers at...
 (866) CED-ELEV • (866) 233-3538
www.cedelevator.com

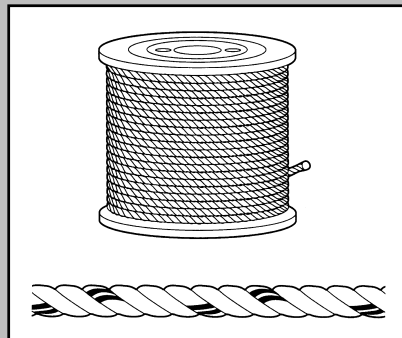
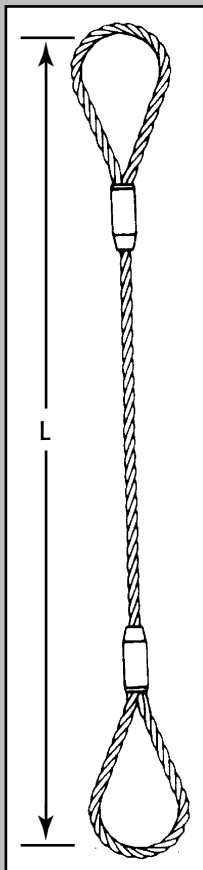

Wire Rope Sling & Twisted Rope

Wire Rope Sling

These general purpose slings are made from 6 x 19 type, X.I.P., IWRC Cable. This type of sling is great for general material handling. The slings come with an eye on each end made with a mechanical fastener. Capacity used in a vertical lift is as follows: $\frac{3}{8}$ " : 2,200lbs., $\frac{1}{2}$ " : 4,000lbs., $\frac{5}{8}$ " : 6,200lbs.

Part Number	Width/Length	Capacity
ALT 124	$\frac{1}{2}$ " x 4'	4,000 lbs.
ALT 126	$\frac{1}{2}$ " x 6'	4,000 lbs.
ALT 128	$\frac{1}{2}$ " x 8'	4,000 lbs.
ALT 1210	$\frac{1}{2}$ " x 10'	4,000 lbs.
ALT 1212	$\frac{1}{2}$ " x 12'	4,000 lbs.
ALT 382	$\frac{3}{8}$ " x 2'	2,200 lbs.
ALT 383	$\frac{3}{8}$ " x 3'	2,200 lbs.
ALT 384	$\frac{3}{8}$ " x 4'	2,200 lbs.
ALT 386	$\frac{3}{8}$ " x 6'	2,200 lbs.
ALT 3810	$\frac{3}{8}$ " x 10'	2,200 lbs.
ALT 3812	$\frac{3}{8}$ " x 12'	2,200 lbs.
ALT 583	$\frac{5}{8}$ " x 3'	6,200 lbs.
ALT 586	$\frac{5}{8}$ " x 6'	6,200 lbs.
ALT 588	$\frac{5}{8}$ " x 8'	6,200 lbs.
ALT 5812	$\frac{5}{8}$ " x 12'	6,200 lbs.

Polyester Rope

This highly versatile rope combines low stretch with high strength offering dependability and unsurpassed resistance to abrasion, sunlight and common chemicals

Part Number	Diameter x Length	Capacity
1AP-240-06S	$\frac{3}{4}$ " x 600ft.	2,100lb.
1AP-240-12S	$\frac{3}{4}$ " x 1200ft.	2,100lb.

Tackle Blocks, Rope Blocks & Clamps

Wood Tackle Blocks

We stock a variety of single and double blocks. These are regular wood tackle blocks with 3½" galvanized sheaves and metal components for use with ¾" manila rope. Fitted with swivel hook and safety latch. Other configurations available upon request. Wood Tackle Blocks are available with roller or self lubricating bronze bushings.

Part Number	Description
SL101B6SH	Single
SL105B6SH	Double



Wire Rope Blocks

Our Wire Rope Blocks are furnished with 8"-diameter painted steel sheaves and self-lub bronze bushings. Fitted with swivel hook and safety latch. We also carry a variety of other designs to fit your needs. Call for sizes and prices.

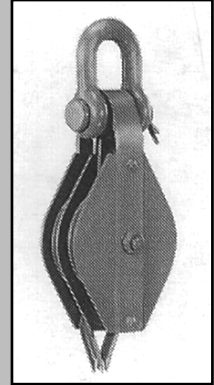
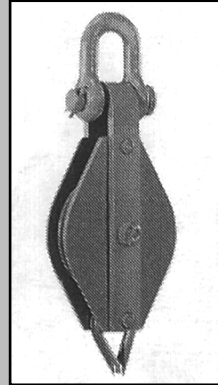
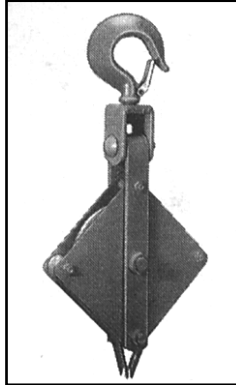

Questions? Answers at...
(866) CED-ELEV • (866) 233-3538
www.cedelevator.com

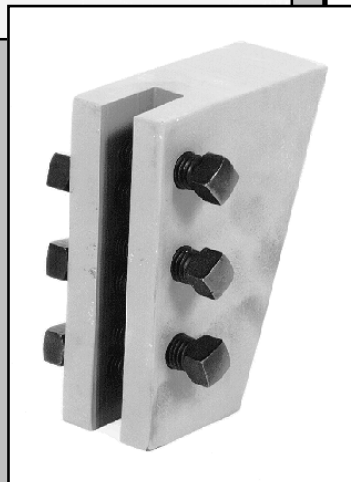
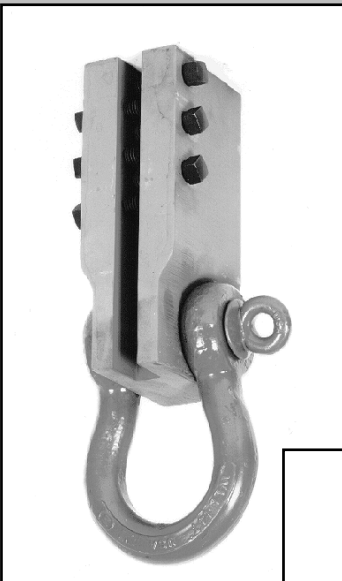
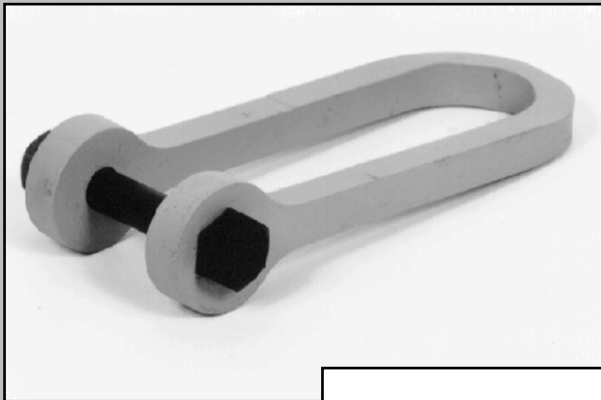
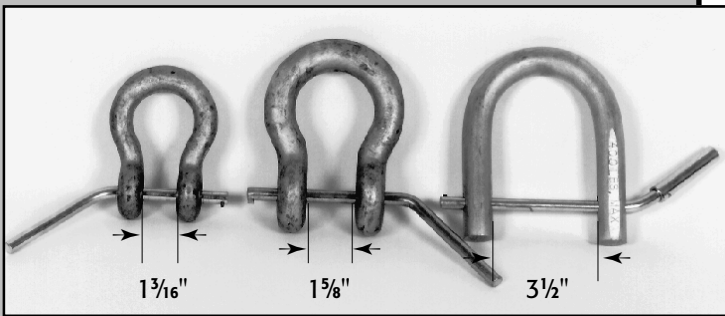

Clevises Chain & Anchor Shackles

Quick Release Clevis

Used for the quick hookup of components in preparation for hoisting. Fits all rail sizes up to and including the 30lb./ft. jumbo (maximum capacity 3500lbs). The #11-260 quick-release clevis has a 3½-inch-wide throat, which allows for hoisting of full section modules fishplate (i.e. seismic/ earthquake) guide rail systems. Can also be used for hoisting many other pieces of equipment.

Part Number	Width	Capacity
11-200	1 3/16"	3500 lbs.
11-250	1 5/8"	2500 lbs.
11-260	3 1/2"	400 lbs.

Crosshead Clevis

Whenever you have a need to hang the car or counterweight. Rated at 4 tons, it eliminates the need for wire rope slings, etc. Simply unbolt, place around crosshead channel, install and tighten bolt. Attach hook from chain fall or any other hoisting means. Saves time and improves safety.
Part Number 11-270

Rail Block/Clevis

Use to hoist your car or counterweight frame at any location in the hoistway.

Part Number	Description
11-180	5/8" Rail Block
11-181	3/4" Rail Block
11-190M	5/8" Rail Block/Clevis
11-191	3/4" Rail Block/Clevis

Chain & Anchor Shackles with Screw Pin

The Chain & Anchor Shackles available with screw pins are forged, quenched and tempered. Alloy pins make for safe use.

Anchor Shackle Part Number	Chain Shackle Part Number	Working Load Limit (Tons)
16-030	16-040	2
16-031	16-041	3 1/4
16-032	16-042	5
16-033	16-043	6 1/2
16-034	16-044	8 1/2
16-035	16-045	9 1/2
16-036	16-046	12
16-037	16-047	14
16-038	16-048	17
16-039	16-049	20

Questions? Answers at...
(866) CED-ELEV • (866) 233-3538
www.cedlevator.com

Clevises & Rail Clamps

Rail Hoisting Clevises

A one piece lever action automatically latches rails in place with no nuts or bolts to drop.

Part Number	Description
RHC716	7/16" diameter pin
RHC508	5/8" diameter pin
RHC716S	7/16" diameter pin

Rail Clamps

Repack hydraulic elevators or recable traction elevators with our quality Rail Clamps.* By using two complete sets to hang counterweights and car, you can recable cars at midpoint of hoistway. For use on 8, 12, and 15lb. rails.

Part Number	Description	Anchor Bolt Torque (ft/lb)	Maximum Load (lb.)*
RCB	Bottom clamp	50	20,200
		70	39,000
RCT	Top clamp	50	22,600
		70	36,800
RCS	Set of 2 top and bottom clamps		

*NOTE: Load distribution should be equal on all 4 clamps. Independent Testing Laboratory Rail Clamp Test Results. Complete copy available upon request.

Jumbo Rail Clamps

For use with larger rails. Specify rail weight when ordering.

Part Number	Rail Weight	"A"	Description
18.5RCB-J	18.5 lb.	25/32"	Bottom
18.5RCT-J	18.5 lb.	25/32"	Top
18.5RCS-J	18.5 lb.	25/32"	Set
22.5RCB-J	22.5 lb.	1 5/32"	Bottom
22.5RCT-J	22.5 lb.	1 5/32"	Top
22.5RCS-J	22.5 lb.	1 5/32"	Set
30RCB-J	30.0 lb.	1 9/32"	Bottom
30RCT-J	30.0 lb.	1 9/32"	Top
30RCS-J	30.0 lb.	1 9/32"	Set

Set = 2 Top and 2 Bottom Clamps

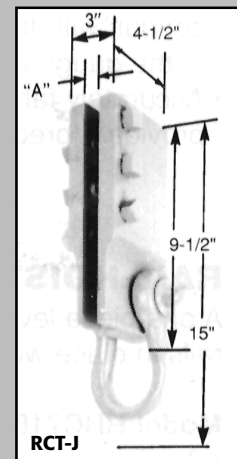
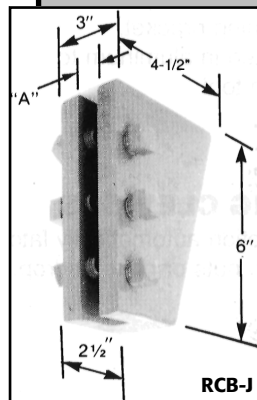
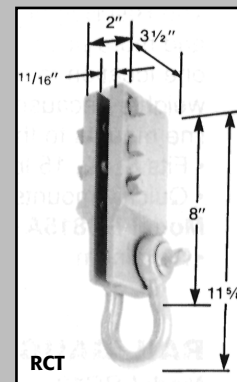
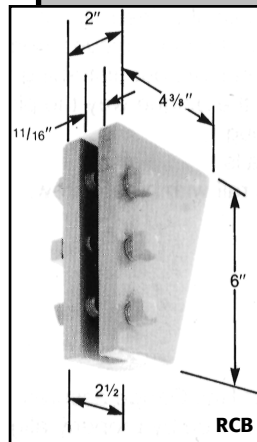
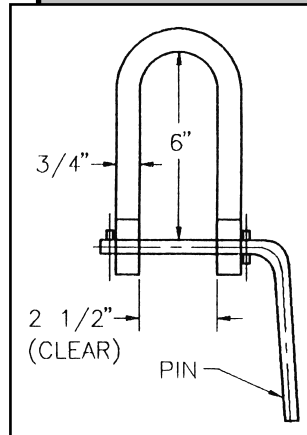

Questions? Answers at...
 (866) CED-ELEV • (866) 233-3538
 www.cedlevator.com

HYDRAULIC INSTALLATION TOOLS

11

In this Section

Portable Filtration System	11.2
Portable Filter Cart	11.2
Temporary Hydro Machine.	11.2
Halo Light Kit.	11.3
Adjustable Plumb Bob	11.3
Pipe Joint Compound.	11.3
Hydro Spider.	11.3

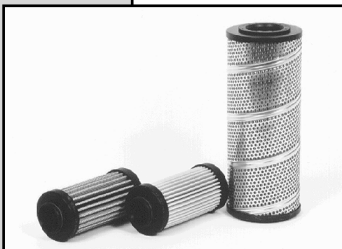
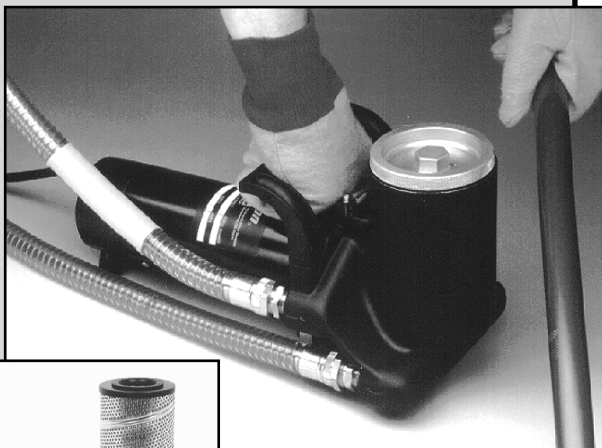

Filtration Systems Hydro Machine

Portable Filtration System

This lightweight, powerful, filtration pump works great for filtering and transferring hydraulic fluid. Weighs only 24 lbs. but can be used with a wide range of fluid viscosities at flows up to 4 GPM. Built of rugged cast aluminum, powered by a 1/4 hp, 110 VAC motor, and designed with an internal relief valve, this pump allows only filtered fluid downstream. Filters are available to remove dirt, metal particles and even water.

Part Number	
10420	Guardian Filter System
10429	Plastic Carrying Case

Portable Filter Cart

This completely self-contained dual filter system is ideal for transferring oil from drum to tank and cleansing the oil in existing systems. The two-stage system is ready to use on 110 volt service. Filter elements for all types of filtering requirements are in stock, including those needed for water removal. Part Number **10400**

Temporary Hydro Machine

Are you required to provide a "running platform" with your hydro and you only have temporary power on a limited basis? Plug this unit into a 230 volt, single phase, 60 Hertz, 20 amp circuit. With a little plumbing to your jack assembly and oil reservoir you are ready to go. Rated at up to 20 GPM at 400 psi Other size units are available. Available with 75ft. pendant. Call for more information.

Part Number	Capacity
10303	3 hp

Questions? Answers at...
(866) CED-ELEV • (866) 233-3538
www.cedlevator.com

Halo Light Kit Plumb Bob, Joint Compound

Halo Light Kit

Mechanically centered by the spider assembly, a light with centering disk is lowered the full length of the casing. The "halo" of light appearing around the outer diameter of the centering disk indicates when plumb is achieved. Standard unit accommodates casings up to 12" in diameter. Unit can be adapted to accommodate larger casings by special order. Kit includes: Spider assembly with 75' of line, 10 aluminum disks, battery powered light and carrying case.

Part Number **10510**



Adjustable Plumb Bob

This solid brass plumb bob with replaceable steel tip, has a spring-loaded, knurled cord spool for easy adjustment of the line length. 20 ft. non-twisting cord is included with plumb bob. A belt sheath is available, along with replacement parts.

Part Number	Description
10600	Plumb Bob
10601	Belt Sheath
10602	Tip, replacement
10603	Cap, replacement

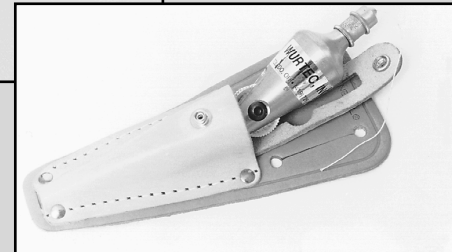

Pipe Joint Compound

This pipe joint compound expands while it sets, tightly sealing the joint. Comes in powder and contains no lead or asbestos, nor does it emit gases when applied or heated. Can be used on most types of pipe. Do not use on unanodized aluminum.

Part Number **MH15735** (1lb. can)



Hydro Spider

The adjustable spider with four spring loaded legs adjusts easily from 3 7/8 to 14 inches in diameter. Great for aligning hydraulic pistons & cylinders because of its wide range of diameter settings.

Part Number **10500**

Questions? Answers at...
(866) CED-ELEV • (866) 233-3538
www.cedlevator.com

INSPECTION, FIRE & SIGNALING DEVICES

12

In this Section

Car Top Inspection Stations . . .	12.2
Inspection Station	
Lights/Buzzers	12.4
Replacement Parts	12.4
Fire Alarm Control Panel	
& Remote Annunciator	12.5
Smoke Detectors	12.5
Alarm Bells & Brass Bells	12.6
Fire Nudging Device	12.7

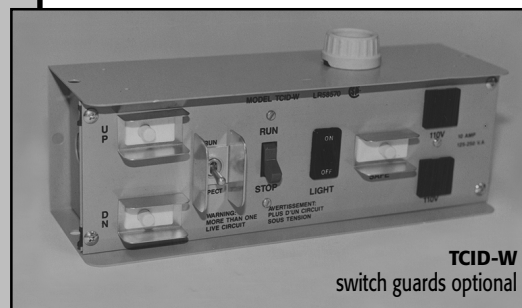
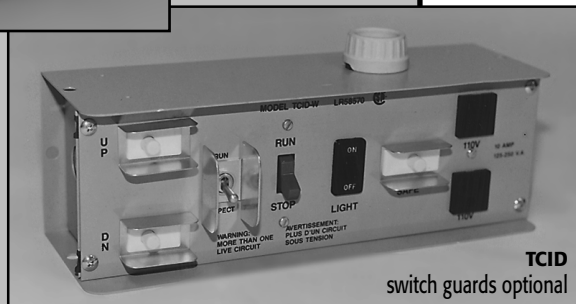

Car Top Inspection Stations

Designed to meet ANSI A17.1 Elevator Safety Code Requirements All models have pre-drilled mounting brackets with ceramic incandescent light bulb socket. Up and down buttons have 2 NO contacts for universal compatibility. Safe button has 1 NO contact. (Contact arrangement can be modified upon request.) CSA approved.

Part Number	Description
TCIG	Fire service buzzer and jewel, with Ground Fault Circuit Interrupter (G.F.I.)
TCIG24	Same as TCIG with 24/48 volt power
TCIGA	Same as TCIG with 6 volt alarm bell mounted
TCIGA-24V	Same as TCIGA with 24/48 volt power
TCIGA-120	Same as TCIGA-120 with G.F.I.
TCIGA-W	Same as TCIGA, pre-wired
TCIGA-W24	Same as TCIGA-24, pre-wired
TCIGNS	Complete TCIG with audible signal in box
TCID	Duplex 3-prong electric cord outlet
TCIDG	Same as TCID with Ground Fault Circuit Interrupter (G.F.I.)
TCIDA	Same as TCID with 6 volt alarm bell mounted
TCIDGA	Same as TCIDG with 6 volt alarm bell mounted
TCIDA-120	Same as TCID with 120 volt alarm bell mounted
TCIDG1-120	Same as TCIDA-120 with G.F.I.
TCIDW	Prewired model

Questions? Answers at...
(866) CED-ELEV • (866) 233-3538
www.cedlevator.com

Inspection Station/ Emergency Lights

Inspection Station/ Emergency Light Combo

Inspection station, emergency light, and alarm bell combined in one cost effective unit. Reduces field installation time. CSA approved

- Designed to meet ANSI A17.1 Elevator Safety Code requirements
- Up and down buttons have 2 NO contacts for universal compatibility. Safe button has 1 NO contact
- Pre-drilled mounting brackets
- Ceramic incandescent light bulb socket
- 6V DC alarm bell
- Remote light source with 5ft. of lead wire
- Nickel cadmium battery and solid state circuitry

Part Number	Description
TCIDEL2	Duplex 3-prong electric cord outlet
TCIDEL2I	Same as TCID-EL2, with added AB6I interrupter bell
TCIDEL2-NB	Inspection station/emergency light without bell
TCIGEL2	Same as TCI-EL2, with added Ground Fault Circuit Interrupter (G.F.I.)
TCIDGEL2	Same as TCID-EL2, with added G.F.I.

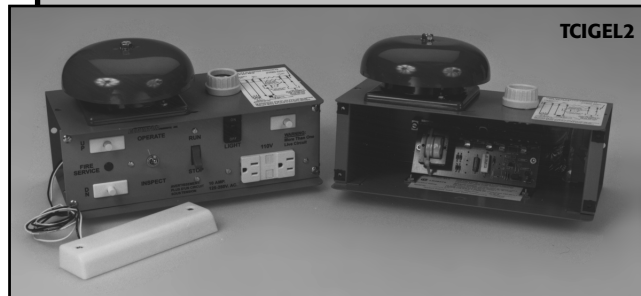
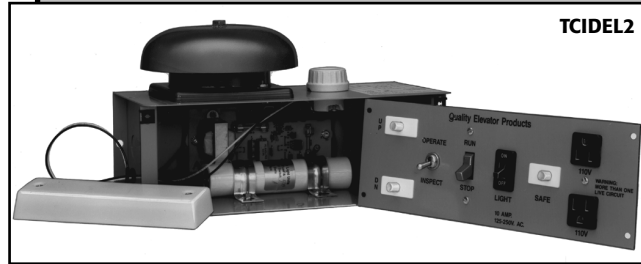

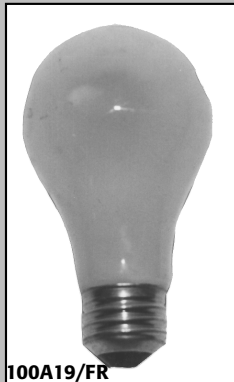

100A19/FR



TCILB

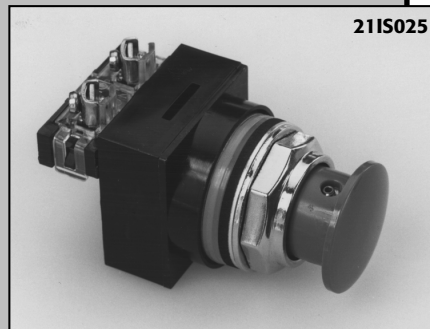

21IS025

Inspection Station Parts

Inspection Station Lights/Buzzers

Part Number	Description
TCILB	Add-on box with fire service buzzer and jewel to bring old inspection stations up to fire codes. 115V AC
TCILB-24	Same as above with 24V DC buzzer and lamp
100A19/FR	100W rough service for use with inspection station
2259	Plastic lamp guard
21002100A	Metal Guard 100W

Inspection Station Replacement Parts

Part Number	Description
21IS001	3 Prong outlet with wires
21IS002	120V AC buzzer
21IS003	On/off light switch
21IS004	Single pole push button switch
21IS006	Toggle switch double pole
21IS007	Jewel
21IS008	Double pole push button switch
15IS004	Light with leads only for TCID-EL2
AB6	6V DC, 6" diameter alarm bell
AB6I	6V DC, 6" diameter alarm bell (interrupter)
AB120	120V DC, 6" diameter alarm bell
21IS005	Ground fault circuit interrupter
21IS011	Double pole red stop switch
21IS014	Buzzer (warble) 10-48 VAC/DC
21IS015	Buzzer (warble) 30-120 VAC/DC
21IS018	Buzzer (vibrating) 24V VAC
21IS019	Buzzer (vibrating) 120V VAC
21PS001	Single pole red stop switch
SO1IS001	Porcelain light socket
21IS003	Mushroom switch assembly with one N.C. contact
21PS003	N.O. contact for mushroom switch
21PS004	N.C. contact for mushroom switch
21CRPXC	Contact only
21CRPBM	Mushroom head and plunger

Questions? Answers at...

(866) CED-ELEV • (866) 233-3538
www.cedlevator.com

Fire Alarm Control Panel Smoke Detectors

Fire Alarm Control Panel

Part Number **SK5208**

A microprocessor based control panel with integrated UL-listed communicator designed for applications requiring smoke detection, manual pull stations, and sprinkler supervision. Features an easy-to-read LCD display with programmable English readout and user friendly tactile keys. The basic unit offers 10 zones of initiation and is expandable up to 30 zones for larger applications. The SK-5208 has a complete line of supervised accessories that provide remote annunciation and auxiliary relay expansion. Ideal for new and retrofit applications.

Remote Annunciator

Part Number **SK5235**

Provides remote annunciation for the SK-5208 Fire Alarm Control Panel. Performs all system operations. Also provides trouble and alarm information and can be used for programming. The SK-5208 can support up to six 5235 Remote Annunciators.

Smoke Detector, Plug-in

Part Number	Description
2W-B	2-Wire
2WBT	2-Wire, 135 Degree Thermal

Smoke Detector, Photoelectric 4-Wire For 24VDC and 120VAC Fire Alarm Systems

Part Number **8100**

Engineered for commercial, industrial, institutional and multi-family housing applications. Compatible with all 4-wire control panels. Exclusive three-position test switch simulates .85% and 3.4% smoke conditions per NFPA 72 and UL 268 standards.

Standard Features

- 24VDC and 120VAC models available
- Compatible with all 4-wire control panels
- Patented three-position test switch
- Form A/Form C contacts for remote annunciation
- Nominal 2.5% sensitivity
- 5:1 signal-to-noise ratio
- Pulsing LED sensing chamber
- Fully insect screened
- Solid State LED condition indicator
- Quick-disconnect wiring harness
- Mounting hardware adapts to standard junction boxes
- Protective high air velocity gasket
- On-site maintenance washing program
- Suitable for releasing device services
- Temporal 3 Evacuation Sounding Device (8003P)



Part Number	Description
6700	Addressable Fire Panel - 100 point
SK-HEAT	Heat Sensor
SK-PHOTO	Smoke Units
SK-RELAY	Relay Modules



Specifications

Detection:	Photoelectric
Wiring:	2-wire
Operating Voltage:	12/24 V non-polarized nominal, 8.5 min. to 35 max.
Maximum Ripple Voltage:	30% of nominal (peak to peak)
Alarm Current:	130mA max., limited by panel
Standby Current:	50 µA max. avg., 100 µA peak
Temperature Range:	32° to 120°F (0° to 49°C)
Humidity Range:	0% to 95% RH, noncondensing
Sensitivity:	2.5%/ft. nominal
Wiring Gauge:	14-22 AWG
Dimensions:	2.0" (51mm) H x 5.3" (127mm) Dia.
Weight:	6.3 oz. (178 g)

Questions? Answers at...
(866) CED-ELEV • (866) 233-3538
www.cedlevator.com



OAB

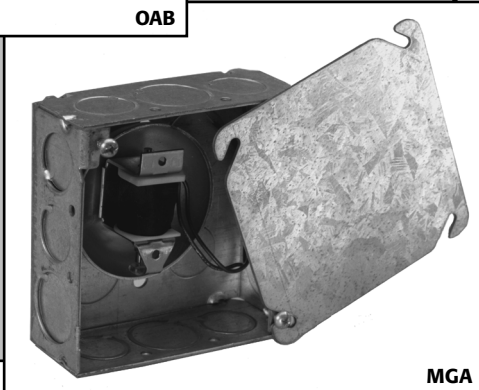

MGA

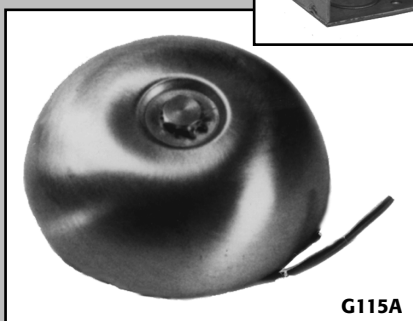

G115A

Alarm Bells & Brass Bells

AB6 is a red bell designed to work off most standard emergency light units. (AB6I & AB12 also red). All bells are built with universal adaptaplates which mount directly on the surface of any single, double or octagon box, for quick, easy, installation.

Part Number	Bell Size	Amp	Voltage	Decibels at 10'
MB-G6-6R	6"	.25	6V DC	92
MB-G6-12R	6"	.18	12V DC	92
43T-G6-115-R	6"	.07	120V AC	92
MB-G6-24R	6"	.03	24V DC	92

Flashing Alarm Bells

Solid state vibrating bell and light for indoor or outdoor use. Installs quickly. Decibel rating 92-94.

AB120F

Red lens removes easily for lamp replacement.

AB6I and AB120I

With interruptor. Specially designed for Canadian market. CSA approved.

Alarm with Flashing Strobe

AB120FS

Heavy duty, vibrating grey bell. Features continuous ring with high decibel output. Solid state, high intensity, long-life xenon strobe, one flash per second. 7.00 ohms, Decibel rating 92-94.

Outdoor Alarm Bell

White box with "Elevator Emergency Call Police" in 2" red letters. Designed to work off standard emergency light unit.

OAB

Rust-proofed for outside use. 9½"h x 137⁄8"w x 3½"d. Provided with Part Number AB6 6V DC bell.

OAB120

Same unit with AB120 alarm bell inside

Brass Bells

2½" diameter single stroke brass bell for elevator floor leveling indication. Includes identifying label with circuit and operational information.

Part Number	Wattage	Voltage	Description
G115A		115V 60Hz	
G25A	25W	115V AC	Wire in series w/hall lantern
G40A	40W	115V AC	Wire in series w/hall lantern
G115D	3400W	115V DC	Wire in parallel w/hall lantern
G25D-62Ω	25W	115V DC	Wire in series w/hall lantern
G40D-30Ω	40W	115V DC	Wire in series w/hall lantern
MGA	25W	115V AC	Brass bell, galvanized steel box

Questions? Answers at...

(866) CED-ELEV • (866) 233-3538
www.cedlevator.com

Fire Service Nudging Device

The VT2000 is a new, patented, UL listed, elevator control device that provides a simple and cost effective retrofit when upgrading to infrared door detectors. Installation is simple and efficient due to a wide front end universal power input, enabling the installer to parallel existing fire service signals and ease of reducing kinetic closing force of doors for fire service. Additional high power relays may be used for external control or signal (ie. to drop door protection during fire service operation, etc.). Enclosure is designed for quick and easy installation.

Q: How does it work?

A: When inputs to fire service phase-1 on the VT2000 become active, an adjustable impedance is applied across A1 and A2 of the door motor armature reducing the kinetic closing force of the doors. When fire service phase-2 on the unit becomes active the impedance is removed from A1 and A2 of the door motor armature, and the elevator doors operate at normal speed.

Q: Does the VT2000 reduce the speed of the doors in the close direction only?

A: Yes. The impedance is polarity conscious, if the doors open slow and close normal speed, simply reverse the wires on A1 and A2 terminals on the VT-2000.

Q: Do I need to put the system on fire service to adjust the speed of the doors?

A: No. With the set-up jumper in place on the VT-2000 you can adjust the speed of the doors in normal operation.

Q: Where do I get the inputs to land on the unit?

A: View it the same as adding a new relay. You parallel the fire service coils, or fire service inputs.

Q: Do I need to mount the VT-2000 on car-top?

A: No. You mount the unit in or on the machine room controller at the source of all your inputs.

Q: Do I need to add new wiring to the elevator door operator?

A: No. You parallel the existing A1 and A2 terminals on the machine room controller to the VT-2000.

Q: Can the VT-2000 disable the door protection from the infrared unit during fire service operation?

A: Yes. The unit has spare form "C" contacts that can be used to open the input on the machine room controller from the infrared unit during fire service.

Q: Can the VT-2000 activate existing nudging circuitry or activate nudging on a new door operator upgrade?

A: Yes. An advantage of the VT-2000 is space management. It's size makes mounting inside or outside of the elevator machine room controller easy. If spare contacts are not available to activate existing nudging circuitry or a new closed loop door operator upgrade the logic is in place to accommodate the required signal.

Q: Are any special tools required to install the VT-2000?

A: No. Typically a drill motor with a bit for self tapping screws, and if mounting on the exterior of the machine room controller a unibit hole saw, or a knock-out.



VT-2000

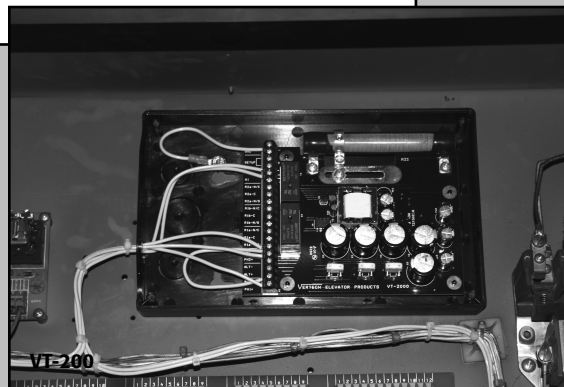

Visit www.vertechelevatorproducts.com for more information and to watch a 5 min. installation video.

External Auxiliary Contact Ratings:	Max switched power:	240 W or 2500 VA
Resistive Load	Max switched current:	3 A
	Max switched voltage:	270 VAC @ 3 A
		24 VDC @ 3 A
		150 VDC @ 0.4 A

Data @ Ambient Temperature 80F	Min	Typical	Max	Units
Input Voltage DC	17		270	VDC
Input Voltage AC	17		270	VAC
Input Current in "Ready" State		0		mA
Input Current @ 24VDC Phase 1 or Alt activation		90		mA
Input Current @ 24VDC Phase 2 activation		62		mA
Unit Activation		250		mSec
Unit Deactivation		250		mSec
Operating Temperature	-5		167	°F

Questions? Answers at...
(866) CED-ELEV • (866) 233-3538
www.cedelevator.com

**KEYS &
KEY KEEPERS**

In this Section

Door Keys 13.2
Door Key Keepers..... 13.2
Fire Key Boxes..... 13.3
Replacement Locks..... 13.3
Replacement Key Boxes..... 13.3
Replacement Keys 13.3

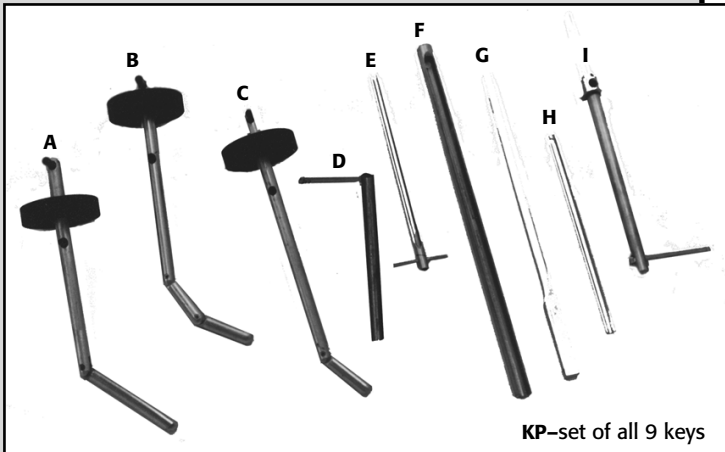

KP—set of all 9 keys

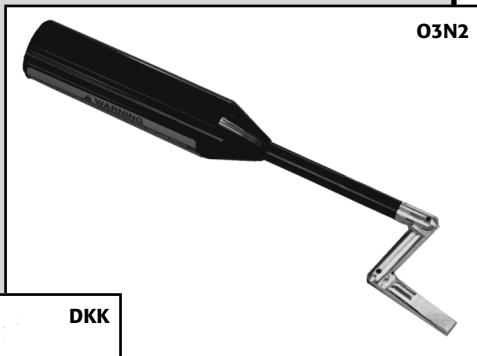

O3N2



DKK

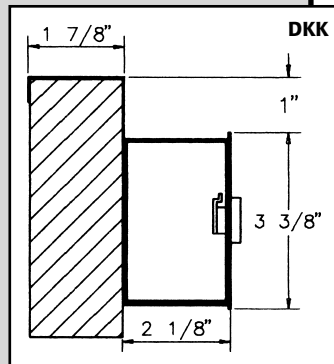

DKK



DKK-KT

Door Keys & Door Key Keepers

Door Keys

All aluminum and steel construction

Key	Part Number	Description
A	O2N	Otis 2 section 5.76" Replacement for Otis #194AD3
B	O3N	Otis 3 section 5.76" Replacement for Otis #194AD7
C	O2N2	Otis 2 section 7.12" Replacement for Otis #194AD4
D	GML	G.A.L. Type M lock
E	OL6	Otis L lock
F	OL10	Otis Lunar 10½" Replacement for Otis # 194D2
G	WT9	Westinghouse "T" 9" L
H	WL6	Westinghouse Lunar 6" L
I	GDK	Replacement for G.A.L. #KMO
KP		Set of all 9 of the above keys
O3N2		Otis 3-section key
OK-1848		DOVER H1848
OK-2389		DOVER H2289
OK-2395		DOVER H2395
OTK-UTA		OTIS-UTA
OTK-UTC		OTIS-UTC
OTK-UTD		OTIS-UTD
OTK-UTG		OTIS-UTG
DK-1		MONTGOMERY MK06
DK-2		MONTGOMERY A00

Door Key Keepers

Part Number **DKK**: Door Key Keeper 2 Keys Included

This sturdy 16-gauge welded steel keeper has one common key, eliminating multiple key confusion and deterring theft. Cadmium-plated to prevent rust, its continuous piano hinge is designed so that the pin cannot be removed. We provide registered keying, preventing unauthorized entry. Additional keys are available upon request.

Part Number **DKK-KT**:

This door key keeper mounts around a door handle. The key is housed in a 2¾"l x 1¼"w x 1⅛"h 16-gauge steel box. We provide registered keying, preventing unauthorized entry. Additional keys are available upon request.

Part Number **K01KKJX124**: Replacement Key For DKK-KT:

REPLACEMENT KEYS FOR DKK PART NUMBER: **K01KK***

*=05, 26, 30, 60, 72, 74, 116

Questions? Answers at...
(866) CED-ELEV • (866) 233-3538
www.cedlevator.com

Fire Key Boxes & Replacement Parts

Fire Key Boxes

Red surface mounted and recess flush mount fire key boxes meet local code requirements. Covers are available in brushed stainless and bronze finishes. Equipped with mounting hooks for service and elevator keys. Rust proofed for outside use. Please specify lock number used in your area.

Dimensions: 9"h x 5³/₈"w x 1³/₈"d**
 Flush model has a 1" frame.

Stainless Surface Mirror		Stainless Flush Mirror	
FKBC/SM		FKBCF/SM	
Bronze Surface	Bronze Flush	Stainless Surface	Stainless Flush
FKB10404B*	FKB10404BF*	FKB10404*	FKB10404F*
FKB52219B*	FKB52219BF*	FKB52219*	FKB52219F*
FKBCB*	FKBCBF*	FKBC*	FKBCF*

*Key included

** Now available with a 2" deep box. Add -2 to part number (i.e. FKBC-2).

Replacement Locks

Lock Part Number	For Box Number
L02KB404	FKB10404
L02KB219	FKB52219
L02KB004	FKBC, FKBT
AKC0071S	Service Cabinet Lock Assembly, Stainless Steel

Replacement Key Boxes

Key Box Part Number	For Box Number
15KB001	FKBC Box & Cover
15KB002	FKBDC, Box & Cover
15KB004	All others Boxes & Covers

Replacement Keys

Key Part Number	Description
K01KB002	(25460 key)
K01KB001	(52219 key)
AKC0052A	Key for Cabinet Lock Keyed AE102
AKC0054A	Key for Cabinet Lock Keyed WD01
AKC0051	Key for Cabinet Lock Keyed MM101
AKC0053	Key for Cabinet Lock Keyed GG101
AKC0056	Key for Cabinet Lock Keyed H341
DCL	FKBDC Key

Other keys for Fire Department use only are available upon request.

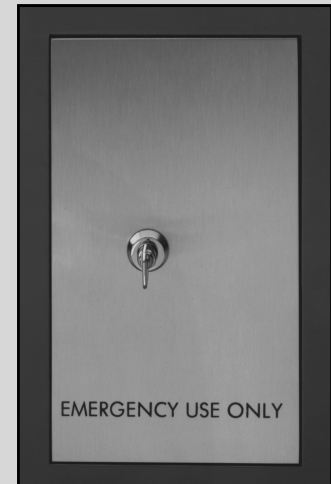
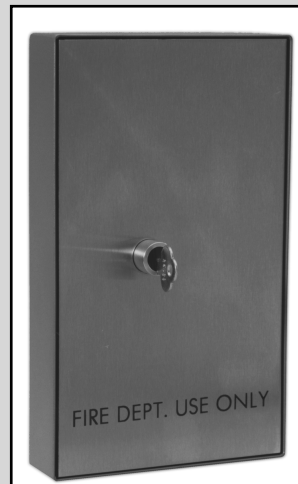

Questions? Answers at...
 (866) CED-ELEV • (866) 233-3538
www.cedlevator.com

LAMPS & LEDs

In this Section

Reflector & Fluorescent Lamps	
Elliptical Reflectors	14.2
Fluorescents	14.2
Compact Fluorescents	14.2
Miniature Lamps	
Bulb and Filament Types	14.3
Base Types	14.4
Product Listing	14.5-11
Based LEDs	
LEDs for Elevator Floor & Call Buttons	14.12
Hall Lanterns	14.12
Elevator Cab Lighting	14.12

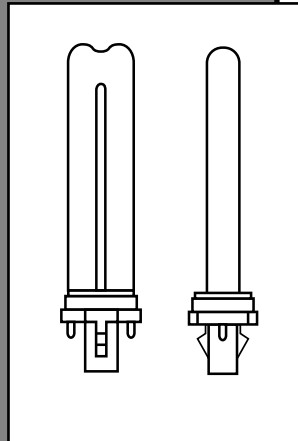
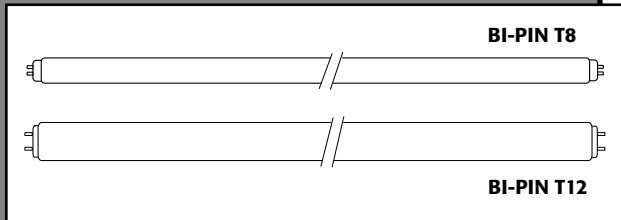
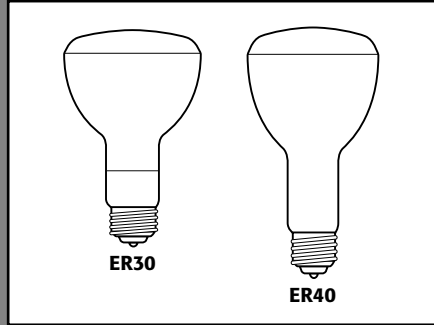

Reflector & Fluorescent Lamps

Elliptical Reflectors

Medium base, 120 and 130 volt.

Part Numbers		
50ER30	75ER30	120ER40

Fluorescents

Available in 2, 3, & 4 foot lengths in cool white, warm white, and various SP, SPX color renditions. Energy efficient available.

Part Numbers		
F17T8CW	F20T12CW	F25T8CW
F30T12CW	F32T8CW	F40CW/RS/WM*

*Osram# F40CWRS/SS

Compact Fluorescents

Low watt BIAx: Energy efficient compact size, long-life replacements for incandescent lamps. Available in 5, 7, 9, and 13 watts in SPX27.

GE Part Numbers	Osram/Sylvania Part Numbers
F5BX/SPX27	CF5DS/827
F7BX/SPX27	CF7DS/827
F9BX/SPX27	CF9DS/827
F13BX/SPX27	CF13DS/827

Also Available in the following color temperatures:	
SPX35	835
SPX41	841
SPX50	850

Miniature Lamp Glass & Filament Types

Basic Lamp Shapes

There are twelve basic glass shapes that most lamps made today are classified by. They are denoted by the letters listed below.

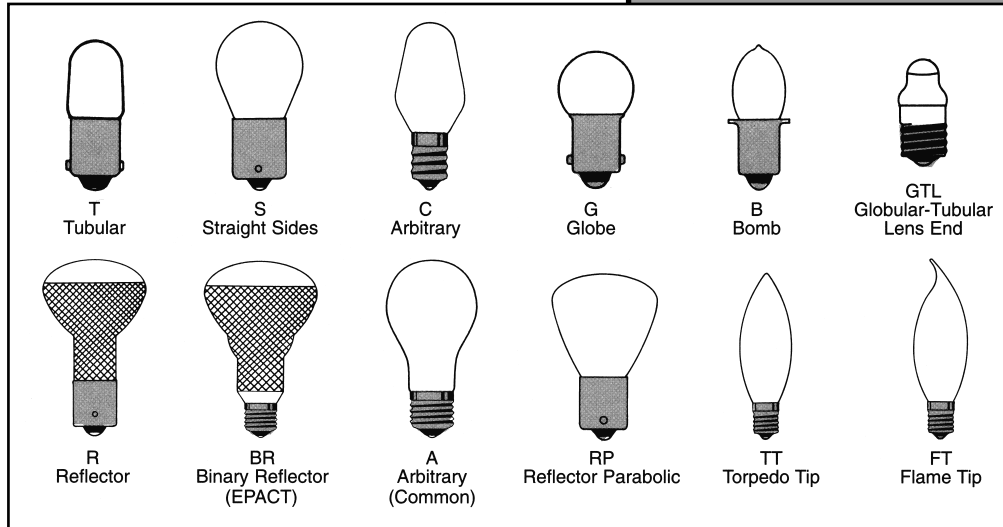

Filament Configurations

Filaments for miniature and subminiature lamps may be straight wire, a coil, or a coiled coil (indicated by the letter **S**, **C**, or **CC**, respectively). Coiling the filament wire effectively shortens the filament length so that smaller bulbs can be used. In addition, in gas-filled lamps, coiling the wire reduces thermal loss and increases efficiency. Tungsten is almost universally used as lamp filament material because of its high melting point at incandescence. The number following the coil identification letter(s) denotes the arrangement of the filaments on the supports.

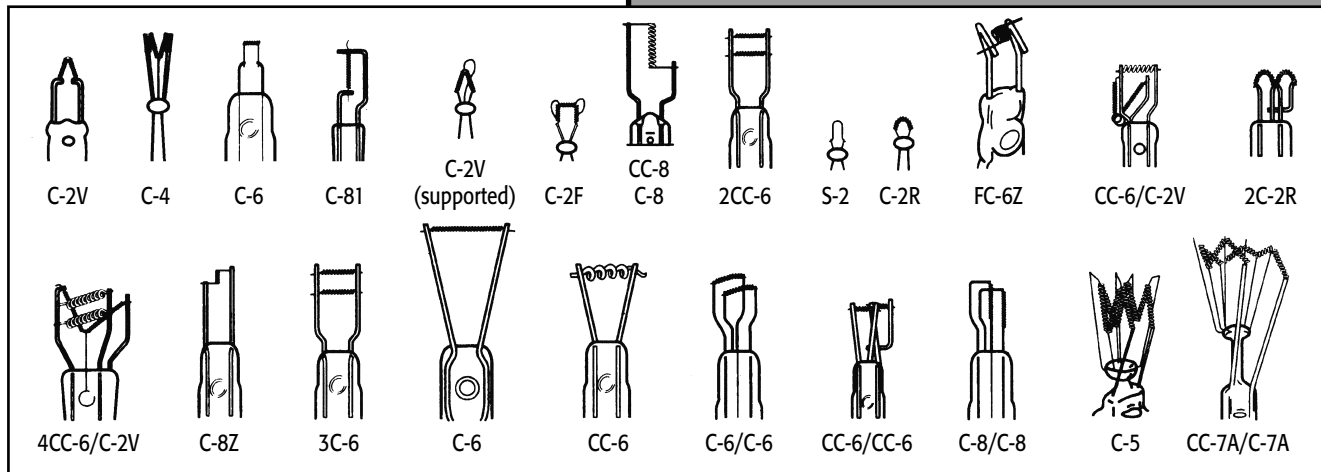

Questions? Answers at...
(866) CED-ELEV • (866) 233-3538
www.cedelevator.com

Miniature Lamp Base Types

Bases provide electrical contact to the lamp and, in most cases, also support the lamp in the fixture. For miniature and subminiature lamps, bayonet or wedge base types are generally preferred over screw types when vibration is present. In addition, wedge bases reduce socket size and complexity. Flanged or collared types are usually associated with requirements for filament location.

ALL DIMENSIONS ARE ± 1%. ALL LENGTH DIMENSIONS INCLUDE THE SOLDER CONTACT.

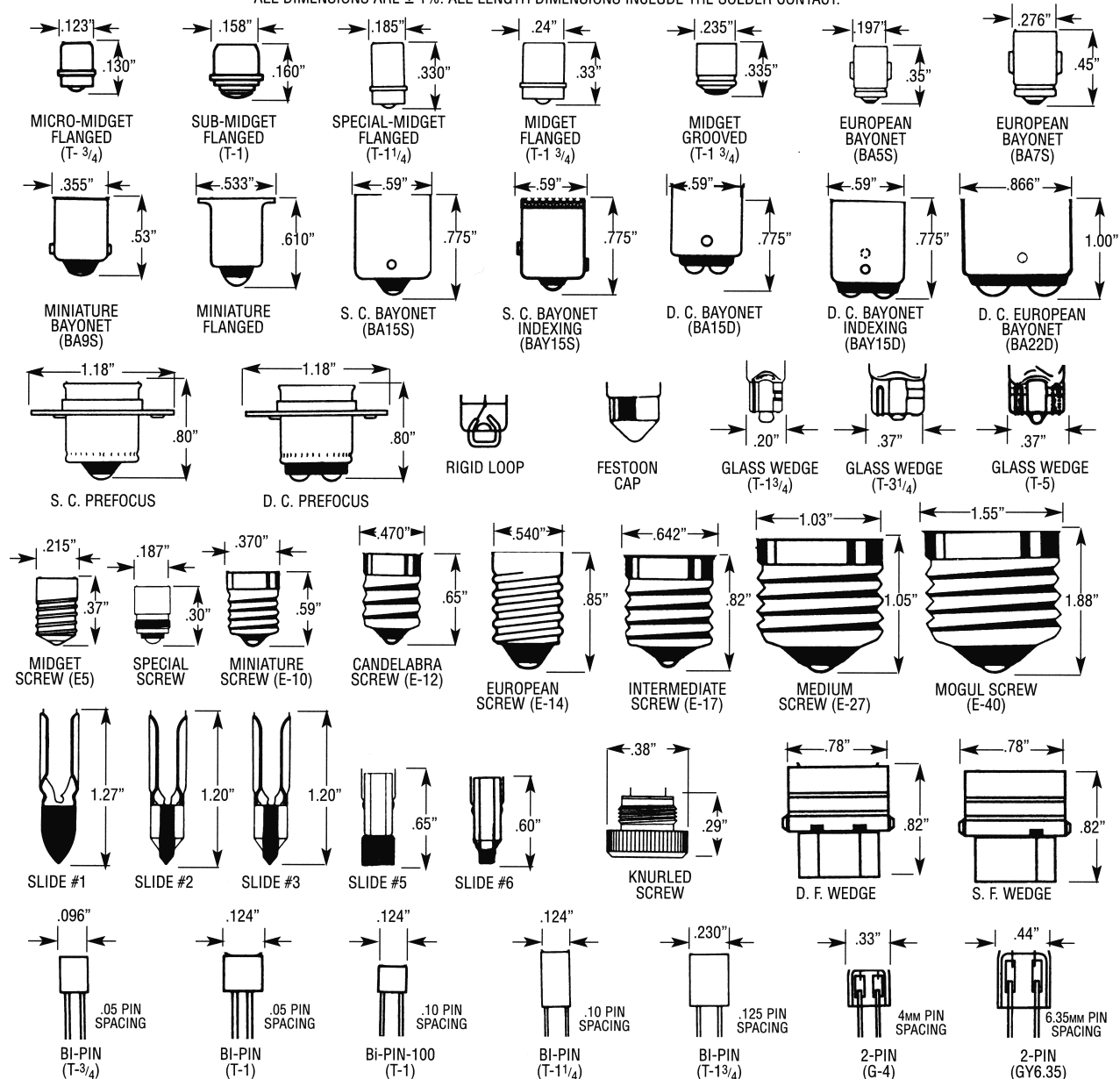

Questions? Answers at...
(866) CED-ELEV • (866) 233-3538
www.cedlevator.com

Miniature Lamps

Commercial Number	Volts	Bulb Type	Base	Length (A)	Width (B)
10	2.5	G3.5	Mini 2-Pin	0.94	0.463
12	6.3	G3.5	Mini 2-Pin	0.94	0.463
13	3.7	G3.5	Mini Screw	0.94	0.463
14	2.47	G3.5	Mini Screw	0.94	0.463
15	7	G4.5	Mini 2-Pin	1.06	0.588
19	14.4	G3.5	Mini 2-Pin	0.94	0.463
27	4.9	G4.5	Mini Screw	1.06	0.588
37	14	T1.75	Wedge	0.72	0.23
43	2.5	T3.25	Mini Bay	1.187	0.41
44	6.3	T3.25	Mini Bay	1.187	0.41
46	6.3	T3.25	Mini Screw	1.187	0.41
47	6.3	T3.25	Mini Bay	1.187	0.41
51	7.5	G3.5	Mini Bay	0.94	0.463
53	14.4	G3.5	Mini Bay	0.94	0.463
55	7	G4.5	Mini Bay	1.06	0.588
57	14	G4.5	Mini Bay	1.06	0.588
63	7	G6	SC Bay	1.44	0.75
64	7	G6	DC Bay	1.44	0.75
67	13.5	G6	SC Bay	1.44	0.75
68	13.5	G6	DC Bay	1.44	0.75
70	14	T1.75	Wedge	0.72	0.23
73	14	T1.75	Wedge	0.72	0.23
74	14	T1.75	Wedge	0.72	0.23
81	6.5	G6	SC Bay	1.44	0.75
82	6.5	G6	DC Bay	1.44	0.75
84	6.3	T1.75	Wedge	0.72	0.23
85	28	T1.75	Wedge	0.72	0.23
86	6.3	T1.75	Wedge	0.72	0.23
88	6.8	S8	DC Bay	2.00	1.04
89	13	G6	SC Bay	1.44	0.75
90	13	G6	DC Bay	1.44	0.75
93	12.8	S8	SC Bay	2.00	1.04
94	12.8	S8	DC Bay	2.00	1.04
97	13.5	G6	SC Bay	1.44	0.75
98	13	G6	SC Bay	1.44	0.75
105	12.8	B6	SC Bay	1.75	0.775
147	7	T3.25	Wedge	1.06	0.41
149	6.15	T3.25	Wedge	1.06	0.41
157	5.8	G6	Mini Screw	1.22	0.75
158	14	T3.25	Wedge	1.06	0.41
161	14	T3.25	Wedge	1.06	0.41
168	14	T3.25	Wedge	1.06	0.41
193	14	T3.25	Wedge	1.06	0.41
194	14	T3.25	Wedge	1.06	0.41
198	12.8/14	S8	D.C. Index	2.00	1.04
199	12.8	S8	SC Bay	2.00	1.04

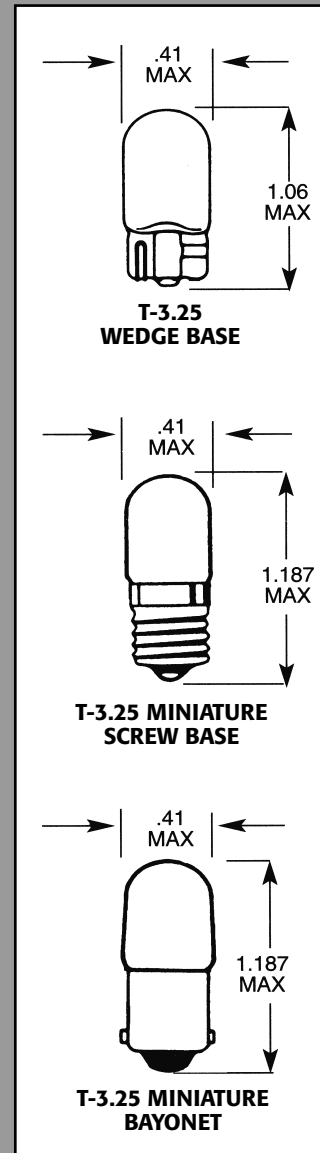

Questions? Answers at...
 (866) CED-ELEV • (866) 233-3538
 www.cedelevator.com

Miniature Lamps

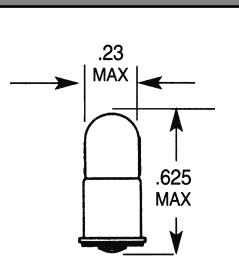

**T-1.75 MIDGET
FLANGED BASE**

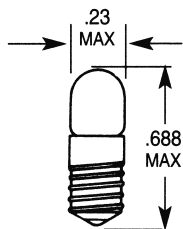

**T-1.75 MIDGET
PLANGED BASE**

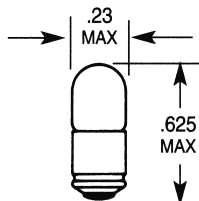

**T-1.75 MIDGET
GROOVED BASE**

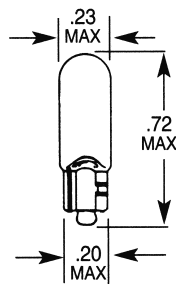

**T-1.75
WEDGE BASE**

Commercial Number	Volts	Bulb Type	Base	Length (A)	Width (B)
210	6.5	B6	DC Bay	1.75	0.775
238	6.3	T1.75	Mini Bay	1.187	0.41
257	14	G4.5	Mini Bay	1.06	0.588
258	14	G4.5	Mini Screw	1.06	0.588
259	6.3	T3.25	Wedge	1.06	0.41
265	28	G3.5	Mini Bay	0.94	0.463
267	6.3	T3.25	Mini Bay	1.187	0.41
293	14	G4.5	Mini Bay	1.06	0.588
301	28	G5	SC Bay	1.38	0.64
302	28	G5	DC Bay	1.38	0.64
303	28	G6	SC Bay	1.44	0.75
304	28	G6	DC Bay	1.44	0.75
305	28	S8	SC Bay	2.00	1.04
306	28	S8	DC Bay	2.00	1.04
307	28	S8	SC Bay	2.00	1.04
308	28	S8	DC Bay	2.00	1.04
309	28	S11	SC Bay	2.38	1.42
311	28	S11	SC Bay	2.38	1.42
313	28	T3.25	Mini Bay	1.187	0.41
315	28	S8	SC Bay	2.00	1.04
316	6	T3.25	Mini Bay	1.187	0.41
327	28	T1.75	SC Mid Flg	0.625	0.23
328	6	T1.75	SC Mid Flg	0.625	0.23
330	14	T1.75	SC Mid Flg	0.625	0.23
334	28	T1.75	Mdgt Gvd	0.625	0.23
349	6.3	T1.75	SC Mid Flg	0.625	0.23
356	28	G3.5	Mini Bay	0.94	0.463
380	6.3	T1.75	Midget Flanged	0.625	0.23
381	6.3	T1.75	SC Mid Flg	0.625	0.23
382	14	T1.75	SC Mid Flg	0.625	0.23
385	28	T1.75	SC Mid Flg	0.625	0.23
386	14	T1.75	Mdgt Gvd	0.625	0.23
387	28	T1.75	SC Mid Flg	0.625	0.23
388	28	T1.75	Mdgt Gvd	0.625	0.23
400	28	T3.25	Wedge	1.06	0.41
425	5	G4.5	Mini Screw	1.06	0.588
456	28	G4.5	Mini Bay	1.06	0.588
464	28	T3.25	Wedge	1.06	0.41
502	5.1	G4.5	Mini Screw	1.06	0.588
503	5.1	G4.5	Mini Bay	1.06	0.588
509	24	G6	SC Bay	1.44	0.75
509K	24	G6	Cand Screw	1.38	0.75
555	6.3	T3.25	Wedge	1.06	0.41
558	13	T3.25	Wedge	1.06	0.41
561	12.8	T3	Rgd Loop	44mm	11mm
562	13.5	T3	Rgd Loop	44mm	11mm

Questions? Answers at...
 (866) CED-ELEV • (866) 233-3538
www.cedlevator.com

Miniature Lamps

Commercial Number	Volts	Bulb Type	Base	Length (A)	Width (B)
605	6.15	G4.5	Mini Screw	1.06	0.588
623	28	G6	SC Bay	1.44	0.75
624	28	G6	DC Bay	1.44	0.75
631	14	G6	SC Bay	1.44	0.75
656	28	T3.25	Wedge	1.06	0.41
657	28	T3.25	Wedge	1.06	0.41
658	14	T3.25	Wedge	1.06	0.41
685	5	T1	Sub-Midget Flg	0.375	0.125
705	28	S8	SC Bay	2.00	1.04
755	6.3	T3.25	Mini Bay	1.187	0.41
756	14	T3.25	Mini Bay	1.187	0.41
757	28	T3.25	Mini Bay	1.187	0.41
904	13.5	T5	Wedge	1.49	0.65
906	13	T5	Wedge	1.49	0.65
908	6	T5	Wedge	1.49	0.65
909	6	T5	Wedge	1.49	0.65
912	12.8	T5	Wedge	1.49	0.65
914	4	T5	Wedge	1.49	0.65
915	12	T5	Wedge	1.49	0.65
916	13.5	T5	Wedge	1.49	0.65
917	12	T5	Wedge	1.49	0.65
918	12.8	T5	Wedge	1.49	0.65
921	12.8	T5	Wedge	1.49	0.65
922	12.8	T5	Wedge	1.49	0.65
926	4	T5	Wedge	1.49	0.65
927	6	T5	Wedge	1.49	0.65
939	6	T5	Wedge	1.49	0.65
967	130	T3.25	Mini Bay	1.187	0.41
1003	12.8	B6	SC Bay	1.75	0.775
1004	12.8	B6	DC Bay	1.75	0.775
1034	12.8/14	S8	DC Index	2.00	1.04
1062	40	RP11	DC Bay	2.25	1.42
1073	12.8	S8	SC Bay	2.00	1.04
1076	12.8	S8	DC Bay	2.00	1.04
1129	6.4	S8	SC Bay	2.00	1.04
1133	6.2	RP11	SC Bay	2.25	1.42
1141	12.8	S8	SC Bay	2.00	1.04
1142	12.8	S8	DC Bay	2.00	1.04
1152	12.8	S8	DC Bay	2.00	1.04
1154	6.4/7	S8	DC Index	2.00	1.04
1155	13.5	G6	SC Bay	1.44	0.75
1156	12.8	S8	SC Bay	2.00	1.04
1157	12.8/14	S8	DC Index	2.00	1.04
1176	12.8/14	S8	DC Bay	2.00	1.04
1195	12.5	RP11	SC Bay	2.25	1.42
1196	12.5	RP11	DC Bay	2.25	1.42

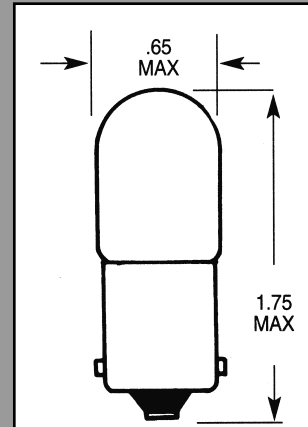

T-5 SINGLE CONTACT BAYONET BASE

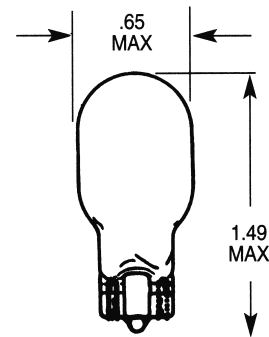

T-5 GLASS WEDGE BASE

Miniature Lamps

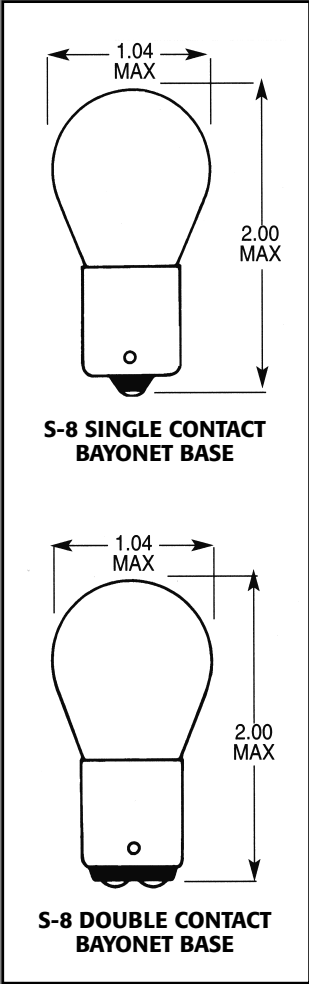

Commercial Number	Volts	Bulb Type	Base	Length (A)	Width (B)
1203	28	S8	SC Bay	2.00	1.04
1224	34	G6	DC Bay	1.44	0.75
1251	28	G6	SC Bay	1.44	0.75
1252	28	G6	DC Bay	1.44	0.75
1308	28	B6	SC Bay	1.75	0.775
1309	28	B6	SC Bay	1.75	0.775
1315	2.5	G5	SC Bay	1.38	0.64
1317	6	B6	SC Bay	1.75	0.775
1383	13	R12	SC Bay	2.63	1.55
1385	28	R12	SC Bay	2.63	1.55
1388	24	R12	DC Bay	2.63	1.55
1408	10	T3.25	Mini Bay	1.187	0.41
1434	3.7	T5	SC Bay	1.75	0.65
1445	14.4	G3.5	Mini Bay	0.94	0.463
1449	14	G3.5	Mini Screw	0.94	0.463
1450	24	G3.5	Mini Bay	0.94	0.463
1460	6.5	S8	DC Pf. (A)	2.00	1.04
1468	6	S8	DC Pf. (S)	2.00	1.04
1476	18	T3	Mini Screw	1.20	0.38
1477	24	T3	Mini Screw	1.20	0.38
1487	14	T3.25	Mini Screw	1.187	0.41
1493	6.5	S8	DC Bay	2.00	1.04
1495	28	T4.5	Mini Bay	1.38	0.588
1561	6.3	S11	SC Prefocus	2.38	1.42
1591	28	S8	SC Bay	2.00	1.04
1594	6	S8	DC Bay	2.00	1.04
1612	5.4	S8	DC Bay	2.00	1.04
1619	6.7	S8	SC Bay	2.00	1.04
1665	28	S8	SC Bay	2.00	1.04
1680	6	S8	SC Bay	2.00	1.04
1683	28	S8	SC Bay	2.00	1.04
1691	28	S8	SC Bay	2.00	1.04
1692	28	S8	DC Bay	2.00	1.04
1813	14.4	T3.25	Mini Bay	1.187	0.41
1815	14	T3.25	Mini Bay	1.187	0.41
1816	13	T3.25	Mini Bay	1.187	0.41
1818	24	T3.25	Mini Bay	1.187	0.41
1819	28	T3.25	Mini Bay	1.187	0.41
1820	28	T3.25	Mini Bay	1.187	0.41
1822	36	T3.25	Mini Bay	1.187	0.41
1828	37.5	T3.25	Mini Bay	1.187	0.41
1829	28	T3.25	Mini Bay	1.187	0.41
1835	55	T3.25	Mini Bay	1.187	0.41
1843	28	T3.25	Mini Bay	1.187	0.41
1847	6.3	T3.25	Mini Bay	1.187	0.41
1850	5	T3.25	Mini Bay	1.187	0.41

Questions? Answers at...
 (866) CED-ELEV • (866) 233-3538
www.cedlevator.com

Miniature Lamps

Commercial Number	Volts	Bulb Type	Base	Length (A)	Width (B)
1864	28	T3.25	Mini Bay	1.187	0.41
1866	6.3	T3.25	Mini Bay	1.187	0.41
1873	28	T3.25	Mini Bay	1.187	0.41
1876	3.5	T5	SC Bay	1.75	0.65
1889	14	T3.25	Mini Bay	1.187	0.41
1891	14	T3.25	Mini Bay	1.187	0.41
1892	14.4	T3.25	Mini Bay	1.187	0.41
1893	14	T3.25	Mini Bay	1.187	0.41
1895	14	G4.5	Mini Bay	1.06	0.588
2232	28	S8	SC Bay	2.00	1.04
2233	28	S8	SC Bay	2.00	1.04
3011	28	S11	SC Bay	2.38	1.42
7387	28	T1.75	Bi-Pin M-23	0.875	0.23
100A/RS	120	A19	Med. Screw	4.44	2.12
100A	130	A19	Med. Screw	4.44	2.12
100A21/RS/SL	120	A21	Med. Screw	5.31	2.62
10C7	120	C7	Cand Screw	2.13	0.875
10C7DC	115	C7	DC Bay	2.19	0.875
10S11N/CL	130	S11	Cand Screw	2.25	1.42
10S14/IF	120	S14	Med. Screw	3.50	1.75
10S6/DC/AMBER*	250	S6	DC Bay	1.81	0.775
10S6/DC/CL	250	S6	DC Bay	1.81	0.775
10S6/DC/GRN*	250	S6	DC Bay	1.81	0.775
10S6/DC/RED*	250	S6	DC Bay	1.81	0.775
10S6	230	S6	Cand Screw	1.88	0.75
120MB	120	T2.5	Mini Bay	1.20	0.32
120PSB	120	T2	Slide #5	1.10	0.275
120RB	120	T2	Mini Bay	1.22	0.91
120RC	120	T2	Cand Screw	1.22	0.91
12MB	12	T2.5	Mini Bay	1.20	0.32
12PSB	12	T2	Slide #5	1.10	0.275
12RB	12	T2	Mini Bay	1.22	0.91
12RC	12	T2	Cand Screw	1.22	0.91
130MB	130	T2.5	Mini Bay	1.20	0.32
1383TF	13	R12	SC Bay	2.63	1.55
155MB	155	T2.5	Mini Bay	1.20	0.32
155PSB	155	T2	Slide #5	1.10	0.275
15A15	120	A15	Med. Screw	3.50	1.88
15T6	120	T6	Cand Screw	3.06	0.77
15T6/CAND	145	T6	Cand Screw	3.06	0.77
15T7C	120	T7	Cand Screw	2.25	0.88
15WPCL130E14	120	S8	E14	57mm	26mm
194B	14	T3.25	Wedge	1.06	0.41
194G	14	T3.25	Wedge	1.06	0.41
194NA	14	T3.25	Wedge	1.06	0.41

*painted

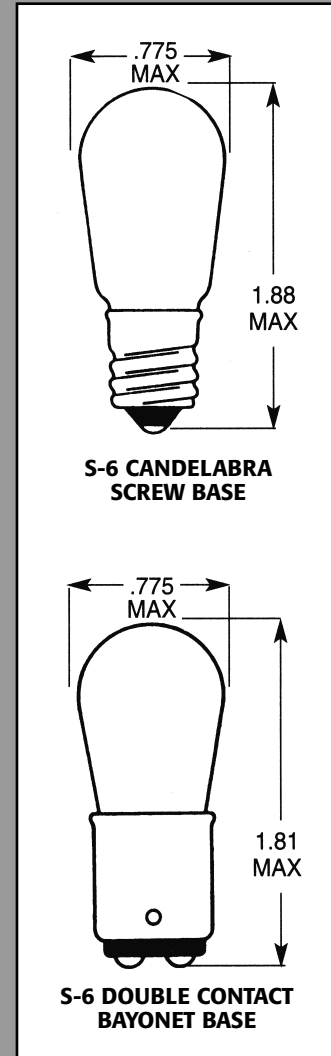

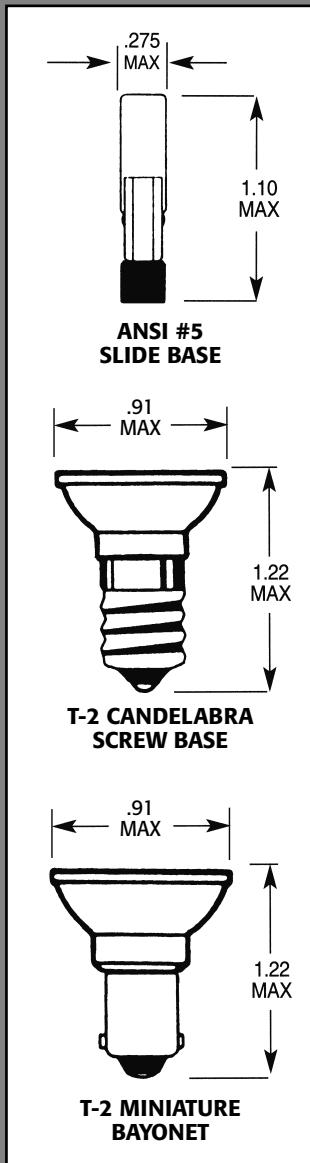

Miniature Lamps

Commercial Number	Volts	Bulb Type	Base	Length (A)	Width (B)
194R	14	T3.25	Wedge	1.06	0.41
240MB	240	T2.5	Mini Bay	1.20	0.32
24CSB	24	T2	Slide #5	0.90	0.275
24MB	24	T2.5	Mini Bay	1.20	0.32
24PSB	24	T2	Slide #5	1.10	0.275
24RB	24	T2	Mini Bay	1.22	0.91
24RC	24	T2	Cand Screw	1.22	0.91
253X	2.5	TL1.75	Midget Grvd	0.625	0.23
25A120	120	A19	Med. Screw	4.44	2.12
25A230	230	A19	Med. Screw	4.44	2.12
25S11/2C120	120	S11	Cand Screw	2.25	1.42
25S1-1/2-CRV 115	115	S1.5	Cand Screw	2.12	1.38
25S6/130CS	130	S6	Cand Screw	1.88	0.775
25T10/120	120	T10	Med. Screw	5.62	1.25
25T8/DC/120	120	T8	DC Bay	2.63	1.04
25T8-130V-CS	130	T8	Cand Screw	2.63	1.04
25T8DC	130	T8	DC Bay	2.63	1.04
25T8N/120	120	T8	Intermediate Scrw	2.63	1.04
25T8N130	130	T8	Intermediate Scrw	2.63	1.04
28MB	28	T2.5	Mini Bay	1.20	0.32
28PSB	28	T2	Slide #5	1.10	0.275
28RB	28	T2	Mini Bay	1.22	0.91
28RC	28	T2	Cand Screw	1.22	0.91
35PSB	35	T2	Slide #5	1.10	0.275
37Q	14	T1.75	Wedge	0.72	0.23
3S6130	130	S6	Cand Screw	1.88	0.775
40T8/130	130	T8	Med. Screw	11.88	1.04
48C2	48	T2	Tel. Slide #2	1.69	0.26
48MB	48	T2.5	Mini Bay	1.20	0.32
48PSB	48	T2	Slide #5	1.10	0.275
48RB	48	T2	Mini Bay	1.22	0.91
48RC	48	T2	Cand Screw	1.22	0.91
509K	24	G6	Cand Screw	1.38	0.75
60A/120	120	A19	Med. Screw	4.44	2.12
60MB	60	T2.5	Mini Bay	1.20	0.32
60PSB	60	T2	Slide #5	1.10	0.275
60RB	60	T2	Mini Bay	1.22	0.91
60RC	60	T2	Cand Screw	1.22	0.91
6MB	6	T2.5	Mini Bay	1.20	0.32
6PSB	6	T2	Slide #5	1.10	0.275
6RB	6	T2	Mini Bay	1.22	0.91
6RC	6	T2	Cand Screw	1.22	0.91
6S6/CL/12	12	S6	Cand Screw	1.88	0.775
6S6/CL/120	120	S6	Cand Screw	1.88	0.775
6S6/CL/145	145	S6	Cand Screw	1.88	0.775
6S6/CL/155	155	S6	Cand Screw	1.88	0.775

Questions? Answers at...
(866) CED-ELEV • (866) 233-3538
www.cedlevator.com

Miniature Lamps

Commercial Number	Volts	Bulb Type	Base	Length (A)	Width (B)
6S6/CL/230	230	S6	Cand Screw	1.88	0.775
6S6/CL/30	30	S6	Cand Screw	1.88	0.775
6S6/CL/48	48	S6	Cand Screw	1.88	0.775
6S6/CL/6	6	S6	Cand Screw	1.88	0.775
6S6/CL/60	60	S6	Cand Screw	1.88	0.775
6S6/DC/130	130	S6	DC Bay	1.81	0.775
6S6/DC/145	145	S6	DC Bay	1.81	0.775
6S6CS	230	S6	Cand Screw	1.88	0.775
6S6/DC/24	24	S6	DC Bay	1.81	0.775
6S6/DC/32	32	S6	DC Bay	1.81	0.775
6T4-1/2/CAND	125	T4.5	Cand Screw	1.38	0.588
75A/RS	120	A19	Med. Screw	4.44	2.12
90MB	90	T2.5	Mini Bay	1.20	0.32
A9AC	65AC/90DC	T2	Wire Terminal (1.25")	0.75	0.25
B1A	120	T3 1/4	Mini Bay	1.187	0.41
B2A	120	T3 1/4	Mini Bay	1.187	0.41
F15T12CW	N/A	T12	Med. Bi-pin	1.5	18.0
H43C	14	S6	Cand Screw	1.88	0.75
K1AZR10	125	T2	Slide #5	1.10	0.29
L30120	120	T8	Disc	17.75	1
L40120	120	T8	Disc	11.75	1
L60120	120	T8	Disc	17.75	1
MP123					
NE120RC	120	T2	Cand Screw	1.22	0.91
NE51 (B1A)	120	T3.25	Mini Bay	1.19	0.43
NE57 (F3A)	105-125	T4.25	Cand Screw	1.53	0.58
PR12	5.95	B3.5	SC Mini Flg	1.25	0.445
PR13	4.75	B3.5	SC Mini Flg	1.25	0.445
PR18	7.2	B3.5	SC Mini Flg	1.25	0.445
PR2	2.38	B3.5	SC Mini Flg	1.25	0.445
PR3	3.57	B3.5	SC Mini Flg	1.25	0.445
PR6	2.47	B3.5	SC Mini Flg	1.25	0.445
PR7	3.7	B3.5	SC Mini Flg	1.25	0.445
ST151 (Starter for TLD18W Lamp)	N/A	N/A	N/A	N/A	N/A
TLD18W/17GREEN FL LAMP	N/A	T8	Med. Bi-pin	24.0	1.04

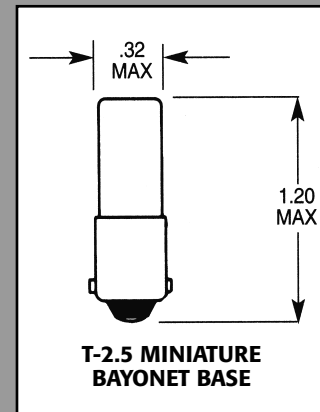



Lamps for Elevator Floor & Call Buttons

Incandescent Part Number	LED Part Number	Voltage	Lamp and Base Type
24PSB	LED24PSB-COLOR-ACDC	24V	T2 #5 SLIDE BASE
28PSB	LED28PSB-COLOR-ACDC	28V	T2 #5 SLIDE BASE
48PSB	LED48PSB-COLOR-ACDC	48V	T2 #5 SLIDE BASE
60PSB	LED60PSB-COLOR-ACDC	60V	T2 #5 SLIDE BASE
120PSB	LED120PSB-COLOR-ACDC	120V	T2 #5 SLIDE BASE
155PSB	LED155PSB-COLOR-ACDC	155V	T2 #5 SLIDE BASE
24MB	LED24MB-COLOR-ACDC	24V	T2.5 MINIATURE BAYONET BASE
28MB	LED28MB-COLOR-ACDC	28V	T2.5 MINIATURE BAYONET BASE
48MB	LED48MB-COLOR-ACDC	48V	T2.5 MINIATURE BAYONET BASE
60MB	LED60MB-COLOR-ACDC	60V	T2.5 MINIATURE BAYONET BASE
90MB	LED90MB-COLOR-ACDC	90V	T2.5 MINIATURE BAYONET BASE
120MB	LED120MB-COLOR-ACDC	120V	T2.5 MINIATURE BAYONET BASE
85	LED-85-COLOR	28V	T1.75 WEDGE BASE
6S6	LED-6S6-120V-COLOR	120V	S6 CANDELABRA SCREW
25T8DC	LEDT18D-120-COLOR	120V	T8 DC BAYONET BASE
502	LED6MSW-ACDC	6V	G4.5 MINIATURE SCREW BASE
657	W904-28-COLOR28V	T3.25	WEDGE BASE

Above lamps available in red, orange, yellow, white, green, blue.

Hall Lanterns

Part Number	Voltage	Replaces	
		Incandescent	Lamp Type
LED6S6	120VAC	25S11	S6 candelabra screw based LED
LED6S6-DC	120VAC	6S6-DC	15mm DC bayonet based LED

Above lamps available in red, orange, yellow, white, green, blue.
ELV419/ELV409 (green only)

Features:

- Maintenance free, easy installation
- Long life, 100,000+ hrs (10 years)
- Solid state, high shock/vibration resistant
- Built-in current limiting resistors
- Low power, high density
- Major power savings

Options:

- Special Voltages
- Industry standard bases
- Bi-Color configuration
- Flashing

Elevator Cab Lighting

Part Number	Base	Wattage	Voltage	Replaces
1383-3W-LED	SCB	3W	12V	20W 1383 Reflector
GBF-LED	DCB	3W	12V	20W GBF Halogen
MR16-3W-LED	Gx5.3 2-Pin	3W	12V/120V	5-25W Halogen MR16
MR11-LED	G24 2-Pin	3W	12V	5-20W Halogen MR11

Features:

- 75%-90% less power consumption vs. incandescent lamps
- 50,000 life hours (10-15x longer life vs. incandescent lamps)
- Powerful lumen output combined with effective light distribution
- Very low heat output to the touch, and no UV light.
- 1-year warranty

If you can't find the LED you are looking for in this catalog, please call us. We are adding new parts to our inventory that may not be shown.



Questions? Answers at...

(866) CED-ELEV • (866) 233-3538
www.cedelevator.com

LIGHTING
FIXTURES

In this Section

Emergency Lighting 15.2
Emergency
Lighting Products 15.3
Emergency Lighting
Replacement Parts 15.3
Fluorescent Strip Light 15.3

ELCM1

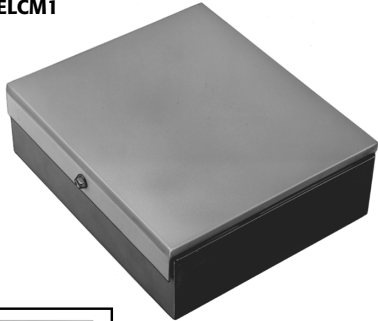

ELPB1

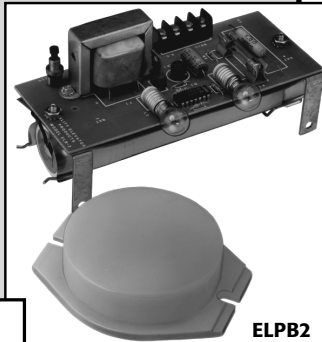
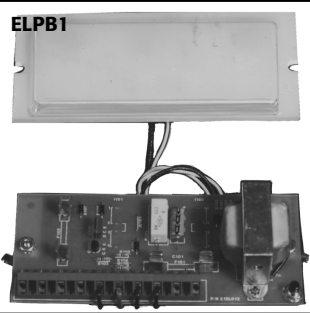

ELPB2

ELSL2



ELSLACBG



ELWS2



Emergency Lighting

Designed for use in new construction, modernization, and direct replacement for existing units. Meeting both lighting and alarm codes ANSI A17.1, these systems contain maintenance-free nickel cadmium batteries and solid state circuitry with accessory terminals for use with 6V DC alarm bell.

ELCM1

Ceiling mount, self-contained unit, with white acrylic lens, optional alarm bell. Can be wired into terminal strip. Dimensions: 6⁵/₁₆" x 5¹/₄" x 1¹³/₁₆".

ELPB1

Mounts inside car operating panel. Power pack, light source, and rectangular lens included. For OEM and replacement use. CSA approved.

ELPB2

Mounts to back of cover plate, 3"-diameter round lens. For OEM and replacement use.

ELSL2

Remote trimline model. Car top mount power supply with alarm bell. 18-gauge galvanized steel box. External test switch. Remote light source, 7" x 1⁷/₈" x 1" (can be mounted in car above operating panel or ceiling). CSA approved.

ELSLACBG

Remote trimline model, similar to model ELSL2 with ground fault circuit interrupter.

ELWS2

Wall surface mount. Brushed stainless steel finish, 5¹/₂" x 8¹/₂". Optional alarm bell can be wired into terminal strip. CSA approved.

ELWS2B

Same as ELWS2 with a bronze electroplated finish.

Emergency Lighting & Replacement Parts

ELS500 Emergency Lighting System

The ELS500 is designed to be tough and is built to last. It converts normal cab lighting of incandescent, halogen, fluorescent or LED to emergency lighting in the event of a normal power failure. This patent-pending UL-listed 120VAC output emergency lighting system powers your choice of one of the following:

- Two (2) incandescent or halogen lamps up to 50 watts each (100 watts total) OR
- Two (2) fluorescent lamps up to 40 watts each (80 watts total) OR
- Two (2) LED lamps up to 40 watts each (80 watts total)

Provides a simple method of meeting emergency lighting code for various lighting designs by using the normal lighting fixtures. The ELS500 works with most existing lightings systems and Man-D-Tec systems.



ELS500 POWER SUPPLY

Sealed Lead-Acid Replacement Battery

Part Number	Nominal Voltage	Nominal Capacity AH	Current @ 20-hr. rate mA	Length	Width	Height	Weight lbs. / kg.	Standard Terminals
PC26-12NB	12	26	1300	6.54	6.88	4.95	18/8.18	F2

Emergency Light Replacement Parts

Part Number	Description
BATBR23A	3V lithium battery with Epson Plug and 5" leads, for T.I., G.E. and Maida micro-processor back-ups. Minimum 5-year shelf life.
15EL001	ELSL2 Power pack w/circuit board & battery
15EL002	ELPB1 Power pack w/circuit board & battery
15EL003	ELCM1 Power pack w/circuit board & battery
15EL004	ELWS2 Power pack w/circuit board & battery
15EL005	ELSL2 Without bell
15EL006	ELSL2 Without lens
15EL007	ELSL2 Lens with leads
15EL008	ELPB1 Lens & bracket
A02EL001	ELWS2 Lens only
A02EL005	ELPB1 Lens only
21EL005	Nicad battery w/5 to 6-year lifespan (approx.)
71LB0035	502 Replacement lamp

Fluorescent Strip Lights

A functional and multi-purpose narrow strip light that incorporates premium performance and construction durability. The performance and application versatility of this series can be increased by incorporating symmetrical or asymmetrical reflectors.

Part Number	Description
8224-217	2' Light Fixture
8248-232WG	2LT 4' Strip w/ Lamp Guard



Questions? Answers at...
 (866) CED-ELEV • (866) 233-3538
www.cedelevator.com

LUBRICANTS & FUNCTIONAL FLUIDS

16

In this Section

Greases

Ball & Roller Bearing Hi-Temp ..	16.2
Hi-Temp Disc Brake/ Wheel Bearing	16.2
Ropeoil Compound	16.2
Hydraulic Oil Additive	16.2
E.P. Moly-Graph® Multi-Purpose	16.3
Super White Multi-Purpose	16.3
Lithium General Purpose	16.3
Extreme Pressure Sta-Plex™ Premium Red	16.3

Lubricants

2-26® Multi-Purpose Precision Lubricant	16.4
Electrical Grade Silicone	16.4

Corrosion Inhibitors

Zinc It® Zinc Spray Coating	16.4
Rust Proof Enamel Spray Paint ..	16.4

Mechanix Orange™ Hand Cleaner .. 16.5

Lectra Clean® Heavy Duty

Degreaser	16.5
-----------------	------

Natural Degreaser™

HydroForce™ Aqueous Cleaners

Grease Buster	16.6
All-Purpose Cleaner/Degreaser ..	16.6
Foaming Cleaner/Degreaser	16.6
Glass Cleaner	16.6

Precision Contact Cleaners

PF™ Precision Cleaner	16.7
Contact Cleaner 2000®	16.7
Duster™ Dust Removal System ..	16.7

RTV Silicone Adhesive/Sealant 16.8

Minute Mend™ Epoxy Putty

Smoke Test®

Wasp & Hornet Killer Plus™



Part Number	Product Name	Container Size	Units per Case
SL3630	Ball & Roller Bearing Hi-Temp Grease	14oz. cartridge	10
SL3160	Hi-Temp Disc Brake Wheel Bearing Grease	14oz. cartridge	10
Q80	Cable Lube	1 gallon	1
MXG	Maxglide Hydraulic Oil Additive	1 quart	12
1U-9891	Hydraulic Oil Additive	1 quart	12

Questions? Answers at...
 (866) CED-ELEV • (866) 233-3538
www.cedlevator.com

Aluminum Complex & Wire Rope Greases

Ball & Roller Bearing Hi-Temp Grease

[Photo not available]

NLGI Grade 2 aluminum complex-based grease formulated specifically to handle the high loads and high temperatures inherent in bearing applications to help increase equipment productivity and life. Formulated with "Moly" and petroleum polymers. Combines moderately high oil viscosity with low temperature pumpability to provide high performance with a wide operating range. Won't wash out, pound, splatter or run out under the heaviest of loads. Resists mild detergent and alkaline wash.

Hi-Temp Disc Brake Wheel Bearing Grease

Very stable, aluminum complex-based thickened grease made from highly refined base oils with rust and oxidation inhibitors. Contains anti-wear, extreme pressure additives and is extremely water resistant with a drop point temperature of 470°F. Fortified with moly disulfide and graphite for extra plating protection. "Tacky" extreme pressure NLGI Grade 2 grease with 40lb. Timken OK rating. Sustains heavy and severe shock loads.

Rope Oil Compound (Q80)

[Photo not available]

Grease lubricant specially formulated for wire rope lubrication. Consists of mineral oil components with special inhibitor and stabilizer additives. The product is used in the manufacture of Messilot® elevator wire ropes, and is approved by all major wire rope manufacturers as a suitable field lubricant.

Maxglide® Hydraulic Oil Additive

How many jobs do you have that are hard to manage because of high traffic and high operating temperatures? Are you increasing leveling speed settings to eliminate chatter? This product has been proven to reduce, or even eliminate serious conditions in regards to unmanageable cylinder packing friction (stick slip, chatter). Safe for submersible motors. Stabilizes operating performance by minimizing packing friction which reduces head reducing operating wear of hydraulic system components.

Hydraulic Oil Additive

[Photo not available]

Low-friction additive, relieves "stick-slip" on noisy hydraulic cylinders.

Lithium-Based Greases

E.P. Moly-Graph® Multi-Purpose Grease

Lithium 12 hydroxy stearate NLGI Grade 2 grease improves metal finish, reduces wear, increases parts life, reduces down-time and increases relubrication intervals. Handles heavy loads, water attack, and shock loads. Contains rust and oxidation inhibitors and extreme pressure additives. Maintains a 40 lb. Timken OK Load.

Super White Multi-Purpose Grease

Lithium-based, water-resistant, NLGI Grade 2 grease for use where cleanliness, appearance and visibility are important. Zinc oxide and titanium dioxide additives reduce friction and wear. Resists water wash out. Dispense manually or through central grease systems.

Lithium General Purpose Grease

Economical, NLGI Grade 2 general purpose grease for use where extreme pressure properties are not required. Highly water resistant; will not break down or run out. Oxidation inhibited. Smooth, buttery consistency. Ideal for automatic or manual dispensing systems.

Extreme Pressure Sta-Plex™ Premium Red Grease

Premium, NLGI Grade 2 lithium complex grease for severe operating conditions involving high loads and high temperatures. Maintains 80 lb. Timken OK Load, indicative of an exceptionally high load wear index and low scar wear properties. Provides superior rust protection and oxidation resistance. Drop Point temperature over 500°F. Can provide lubrication continuously at 300°F. Tackiness additive prevents grease from slinging-off bearings at high rpms. Excellent pumpability in both hot and cold conditions.



Part Number	Product Name	Container Size	Units per Case
SL3330	E.P. Moly-Graph® Multi-Purpose Grease	14oz. Cartridge	10
SL3150	Super White Multi-Purpose Grease	14oz. Cartridge	10
SL3310	Lithium General Purpose Grease	14oz. Cartridge	10
SL3190	E.P. Sta-Plex™ Premium Red Grease	14oz. Cartridge	10

Questions? Answers at...
 (866) CED-ELEV • (866) 233-3538
www.cedelevator.com



Lubricants & Corrosion Inhibitors

2-26® Multi-Purpose Precision Lubricant

Versatile, plastic safe, multi-purpose lubricant, penetrant and corrosion inhibitor. Unique viscosity allows it to cover more surface area and penetrate deep into surfaces of all metals, including steel, copper, brass, and aluminum alloys. Drives out moisture and leaves a thin, long-lasting film to protect against corrosion.

Electrical Grade Silicone

Dry film silicone lubricant provides superior lubricity for metal and non-metal surfaces. Low surface tension permits better coverage and deeper penetration. Non-hardening lubricant minimizes corrosion. Note: This product is labeled extremely flammable. Read and observe label warnings. Do not apply while equipment is energized.

Zinc It®

Acrylic-based, 95% pure zinc coating provides the protection of hot-dipped galvanize with the convenience of an aerosol. Bonds to ferrous metals to provide a sacrificial coating to protect against corrosion. Note: This product is labeled extremely flammable. Read and observe label warnings. Do not apply while equipment is energized.

Rust Proof Enamel Spray Paint

[Photo not available]

Rust resistant, premium quality alkyd enamel, and the premier corrosion fighter in the marketplace. Specifically formulated to resist rusting, peeling and fading. Fights weathering, salt spray and the most severe and demanding industrial conditions. Use with CRC Rust Proof Primer (Part Number 18150, Gray, and 18151, Red Oxide) to guarantee maximum durability. Note: These products are labeled extremely flammable. Read and observe label warnings. Do not apply while equipment is energized. Check local regulations for special storage requirements.

Part Number	Product Name	Type	Container Size	Units per Case
02005	2-26®	Petroleum Oil	16oz.*	12
02094	Electrical Grade Silicone	Silicone	16oz.	12
18114	Machinery Lt Gray Spray Paint (ANSI/ASA 61)		20oz.	

* Available in 2oz., 6oz., 16oz., 1gal., 5gal., and 55gal. containers

Questions? Answers at...
(866) CED-ELEV • (866) 233-3538
www.cedlevator.com

Hand Cleaner & Degreasers

Mechanix Orange™ Citrus Lotion Hand Cleaner with Pumice

Formulated with the natural cleaning power of citrus, it quickly cleans away the toughest soil, grime, ink, oil and paint. Used with or without water, the highly concentrated formula is natural and pH balanced to be gentle on hands. Serious scrubbing power comes from fine-grade pumice. Fortified with glycerine, aloe vera and special conditioners, to leave your hands with a fresh orange scent. Biodegradable and contains no petroleum solvents.



Lectra Clean® Heavy Duty Degreaser

Versatile, non-ozone depleting cleaner/degreaser aggressively removes most industrial soils to help maximize operating performance. Non-flammable, chlorinated solvent evaporates rapidly and dries residue free for quick and easy maintenance of industrial and electrical equipment. For any application permitting the use of chlorinated solvents and not involving sensitive plastics.



Natural Degreaser™

Naturally formulated, biodegradable cleaner/degreaser designed for every day maintenance needs. Superior for tackling grease, tar, oil, adhesives and tree sap. Advanced technology blend evaporates without leaving a residue. Meets OECD 301B standards for biodegradability. Safe on most plastics.

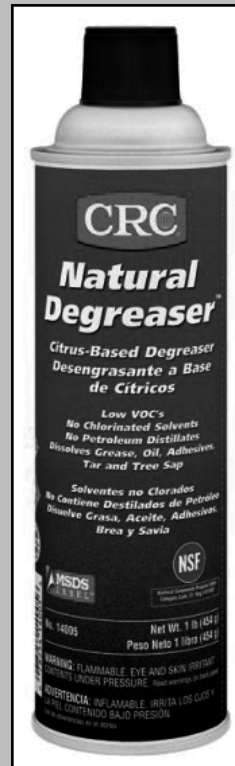

Part Number	Product Name	Type of Cleaner	Container Size	Units per Case
SL1712	Mechanix Orange™	Pumice	16oz.*	12
02018	Lectra Clean®	Chlorinated	20oz.**	12
14005	Natural Degreaser™	Terpene/Glycol Ether	20oz.**	12

* Available in 16oz., and ½ and 1gal. bottles with pump

** Available in 20oz., 1, 5, and 55gal. containers

Questions? Answers at...
 (866) CED-ELEV • (866) 233-3538
www.cedelevator.com

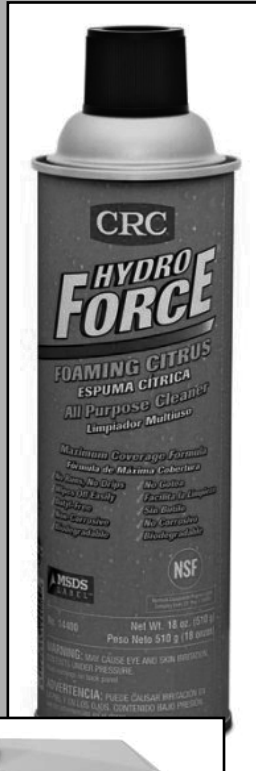
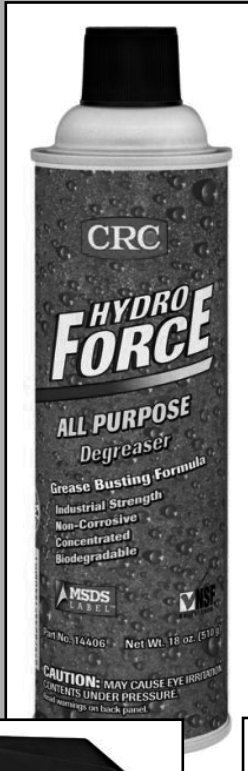

HydroForce™ Aqueous Cleaners

HydroForce™ Grease Buster

A revolutionary new degreaser that attacks grease, oil, and grime, outperforming all other aqueous products. Cleans as well as some solvent-based degreasers, and easily outperforms the leading all-purpose cleaner. May be diluted for use on glass, fiberglass, ceramics and floor coverings.

Hydroforce™ All-Purpose Cleaner/Degreaser

For everyday cleaning of tough dirt, dust, chemicals, and carbon build-up. This cleaner sets the performance standard for butyl-free products. May be diluted for use on glass, fiberglass, ceramics and floor coverings.

Hydroforce™ Foaming Cleaner/Degreaser

A foaming aerosol version of Hydroforce™ All-Purpose Cleaner/Degreaser with citrus scent, that lifts dirt and stains, won't run or drip, and wipes off easily.

Hydroforce™ Glass Cleaner

Gets glass and mirrors sparkling clean. Quickly penetrates road film and other types of surface contaminants.

Part Number	Product Name	Type of Cleaner	Container Size	Units per Case
14406	Grease Buster	H ₂ O Surfactant	20oz. aerosol*	12
14400	Foaming Cleaner/Degreaser	H ₂ O Surfactant	20oz. aerosol	12
14401	All-Purpose Cleaner/Degreaser	H ₂ O Surfactant	30oz. spray*	12
14411	Glass Cleaner	H ₂ O Surfactant	30oz. spray bottle**	12

* Available in 20oz. aerosol, 30oz. spray, 1, 5, and 55 gallon containers

**Available in 20oz. aerosol and 30oz. spray

Questions? Answers at...
(866) CED-ELEV • (866) 233-3538
www.cedlevator.com

Precision Contact Cleaners

PF™ Precision Cleaner

The perfect replacement for CRC 113 where Class II solvents are permitted. Excellent for any application requiring rapid turn-around strong cleaning action, non-flammability and plastic safety. Removes oil build-up, grease dirt, dust, flux and oxidation. Highly recommended for use on transformers, breaker panels, electronics, telephone switching, Datacom and computer equipment.

Contact Cleaner 2000® Precision Cleaner

Developed to aggressively remove oils, greases, and heavy contaminants. Ideal for any application not involving sensitive plastics and requiring nonflammability

Duster™ Dust Removal System

Plastic safe, non-flammable, cleans without wetting surface. Provides a powerful blast that removes dirt, dust and light debris from any surface. Quick maintenance product requiring no dry time. Excellent for removing debris from cracks and joints on non-moveable equipment.

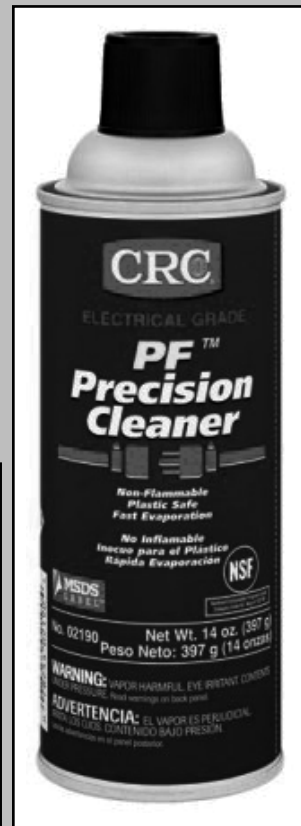

Part Number	Product Name	Type of Cleaner	Container Size	Units per Case
02190	PF™ Precision Cleaner	HFE/HFC	16oz.*	12
02240	Contact Cleaner 2000®	HCFC	16oz.*	12
14085	Duster™	HFC	12oz.	12

* Available in 16oz., 5gal. and 55gal. containers.

Questions? Answers at...
(866) CED-ELEV • (866) 233-3538
www.cedelevator.com



Adhesives & Sealant Smoke Test, Insecticide

RTV Silicone Adhesive/Sealant Clear

Forms a barely visible watertight seal on windows, joints, duct work and most electrical applications. A general purpose, low-visibility sealant. CRC's RTV (Room Temperature Vulcanizing) Adhesives/Sealants require no special tools or caulking guns. The easy-to-use, pressurized container provides the ultimate in control and handling. Revolutionary package seals itself to minimize waste and messy cleanups. It's the simplest way to seal, protect, bond, and waterproof.

Minute Mend™ Epoxy Putty

Two-part epoxy putty packaged in a convenient one piece stick for immediate, long lasting repairs. Permanently repairs scratches, gouges and holes in drums, tanks, pipes, castings, molds, sinks and tubs.

Smoke Test®

Non-staining, plastic safe aerosol spray that tests the functioning of commercial and residential smoke detectors. Eliminates the need to light cigarettes or matches in order to generate smoke. UL Listed.

Wasp & Hornet Killer Plus™

High strength insecticide that reaches out over 20 feet to knock down and kill wasps, hornets, fire ants, all crawling insects, scorpions, spiders, and other stinging insects on contact. Contains no chlorinated solvent and is harmless to plastics. High dielectric strength of 31,700V.

Part Number	Product Name	Container Size	Units per Case
14070	Minute Mend™	4oz	24
14055	RTV Silicone Adhesive/Sealant	8oz.	12
02105	Smoke Test®	4oz.	12
14010	Wasp & Hornet Killer Plus™	20oz.	12

Questions? Answers at...
(866) CED-ELEV • (866) 233-3538
www.cedlevator.com

MECHANICAL PIPING SYSTEMS

17

In this Section

Grooved Couplings

Zero-Flex® Rigid Coupling	17.2
Standard Flexible Coupling	17.2
QuickVic® Rigid Coupling	17.2

Grooved Fittings

Elbows, Tees & Crosses	17.3
Caps and Nipples	17.4
Reducer Threaded	17.4
Swaged Nipples	17.4
Concentric/Eccentric Reducers	17.5
Reducing Tees	17.5

Grooved Valves

With Standard Handle	17.6
3-Piece Threaded Ball Valve With Gear Operator	17.6
Brass Body	17.7

Steel Pipe Nipples & Fittings

Forged Steel Fittings	17.7
Black Hydraulic Piping	17.7
Blain Rupture Valves	17.7

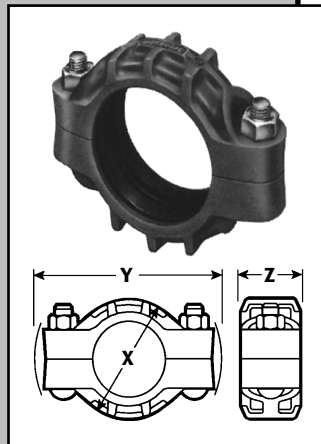
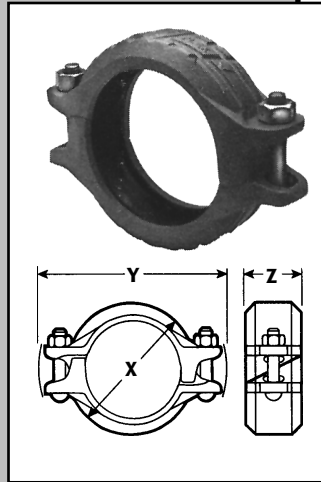

IPS Carbon Steel Pipe Grooved Couplings

Zero-Flex® Rigid Couplings (Style 07)

This unique angle-pad design of Zero-Flex® Style 07 adjusts to standard pipe and roll or cut groove tolerances, positively clamping the pipe to resist flexural and torsional loads. Wider key section fills more of the groove area. (Request 06.02)

Nom. Size	Max. Work Press.	Dimensions			Approx. Wgt. Each
Inches (mm)	PSI (kPa)	X	Y	Z	Lbs (kg)
1 (25)	750 (5175)	2.45 (62)	4.13 (105)	1.88 (48)	1.6 (0.7)
1¼ (32)	750 (5175)	2.60 (66)	4.00 (102)	1.88 (48)	1.6 (0.7)
1½ (40)	750 (5175)	2.94 (75)	4.81 (122)	1.88 (48)	1.6 (0.7)
2 (50)	750 (5175)	3.19 (81)	5.44 (141)	1.88 (48)	2.3 (1.0)
2½ (65)	750 (5175)	3.88 (98)	6.13 (156)	1.88 (48)	2.8 (1.3)
3*	750 (5175)	4.25 (108)	5.75 (146)	1.86 (47)	3.6 (1.6)
3 (80)	750 (5175)	4.56 (116)	6.81 (173)	1.88 (48)	3.1 (1.4)

*O.D. Dimension

Standard Flexible Coupling (Style 77)

Style 77 couplings are designed with cross-ribbed construction to provide a strong component for pressure piping systems. Sizes ¾–12" (20–300mm) are two-piece housings. Sizes 14–22" (350–550mm) are cast in four identical segments, with larger sizes cast in six segments. (Request 06.04)

Nom. Size	Max. Work Press.	Dimensions			Approx. Wgt. Each
Inches (mm)	PSI (kPa)	X	Y	Z	Lbs (kg)
¾ (20)	1000 (6900)	2.13 (54)	3.63 (92)	1.75 (44)	1.1 (0.5)
1 (25)	1000 (6900)	2.38 (60)	3.88 (98)	1.75 (44)	1.3 (0.6)
1¼ (32)	1000 (6900)	2.63 (67)	4.63 (118)	1.75 (44)	2.0 (0.9)
1½ (40)	1000 (6900)	3.00 (76)	5.00 (127)	1.75 (44)	2.1 (1.0)
2 (50)	1000 (6900)	3.63 (92)	5.63 (143)	1.75 (44)	2.6 (1.2)
2½ (65)	1000 (6900)	4.25 (108)	6.25 (159)	1.75 (44)	3.1 (1.4)
3*	1000 (6900)	4.31 (110)	6.31 (160)	1.75 (44)	3.6 (1.6)
3 (80)	1000 (6900)	5.00 (127)	7.00 (178)	1.75 (44)	3.5 (1.6)

*O.D. Dimension

QuickVic® Flexible Coupling (Style 177)

(Also available in Rigid version, Style 107)

This unique angle pad, installation-ready design is ready to install without disassembly of the coupling. Style 177 adjusts to standard pipe and roll or cut groove tolerances, positively clamping the pipe to resist flexural and torsional loads, while reducing installation time. (Request 06.19)

Nom. Size	Max. Work Press.	Joint Assembled Dimensions			Approx. Wgt. Each
Inches (mm)	PSI (kPa)	X	Y	Z	Lbs (kg)
2 (50)	1,000 (6900)	3.66 (93)	5.98 (152)	1.93 (49)	2.7 (1.2)
2½ (65)	1,000 (6900)	4.16 (106)	6.54 (166)	1.94 (49)	3.1 (1.4)
3 (80)	1,000 (6900)	4.82 (111)	7.13 (181)	1.94 (49)	3.5 (1.6)
4 (100)	1,000 (6900)	6.03 (153)	8.43 (214)	2.13 (54)	5.1 (2.3)

Questions? Answers at...
(866) CED-ELEV • (866) 233-3538
www.cedlevator.com

IPS Carbon Steel Pipe Grooved Fittings

Elbows, Tees & Crosses

Ductile Iron (except as noted)

Nominal Size	No. 10 (90° Elbow)		No. 11 (45° Elbow)	
	C to E	Approx. Wgt. Ea.	C to E	Wgt. Ea.
Inches (mm)	Inches (mm)	Lbs (kg)	Inches (mm)	Lbs (kg)
¾ (20)	2.25 (57)	0.5 (0.2)	1.50 (38)	0.5 (0.2)
1 (25)	2.25 (57)	0.6 (0.3)	1.75 (44)	0.6 (0.3)
1¼ (32)	2.75 (70)	1.0 (0.5)	1.75 (44)	0.9 (0.4)
1½ (40)	2.75 (70)	1.1 (0.5)	1.75 (44)	0.9 (0.4)
2 (50)	3.25 (83)	2.0 (0.9)	2.00 (51)	1.4 (0.6)
2½ (65)	3.75 (95)	3.2 (1.5)	2.25 (57)	2.2 (1.0)
3*	3.75 (95)	3.7 (1.7)	2.25 (57)	3.4 (1.5)
3 (80)	4.25 (108)	4.4 (2.0)	2.50 (64)	3.1 (1.4)
2 (50)	16 (406)	6. (2.7)		

Nominal Size	No. 12 (22½° Elbow)		No. 13 (11¼° Elbow)	
	C to E	Approx. Wgt. Ea.	C to E	Wgt. Ea.
Inches (mm)	Inches (mm)	Lbs (kg)	Inches (mm)	Lbs (kg)
¾ (20)	1.63sw (41)	-	1.38 sw (35)	-
1 (25)	3.25 (83)**	0.6 (0.3)	1.38 (35)	0.3 (0.1) sw
1¼ (32)	1.75 (44)	0.8 (0.4) sw	1.38 (35)	0.5 (0.2) sw
1½ (40)	1.75 (44)	0.8 (0.4) sw	1.38 (35)	0.5 (0.2) sw
2 (50)	3.375 (95)**	1.4 (0.6)	1.38 (35)	1.0 (0.5)
2½ (65)	4.00 (102)**	2.3 (1.0)	1.50 (38)	1.5 (0.7) sw
3*	-	-	-	-
3 (80)	4.50 (114)**	3.1 (1.4)	1.50 (38)	2.1 (1.0)

Nominal Size	No. 20 Tee		No. 35 Cross (sw)	
	C to E	Approx. Wgt. Ea.	C to E	Wgt. Ea.
Inches (mm)	Inches (mm)	Lbs (kg)	Inches (mm)	Lbs (kg)
¾ (20)	2.25 (57)	0.6 (0.3)	2.25 (57)	0.9 (0.4)
1 (25)	2.25 (57)	1.0 (0.5)	2.25 (57)	1.3 (0.6)
1¼ (32)	2.75 (70)	1.5 (0.7)	2.75 (70)	2.1 (1.0)
1½ (40)	2.75 (70)	2.0 (0.9)	2.75 (70)	2.5 (1.1)
2 (50)	3.25 (83)	3.0 (1.4)	3.25 (83)	3.8 (1.7) d
2½ (65)	3.75 (95)	4.8 (2.1)	3.75 (95)	6.1 (2.8)
3*	3.75 (95)	7.3 (3.3)	-	-
3 (80)	4.25 (108)	6.8 (3.0)	4.25 (108)	10.5 (4.8)

* O.D. Dimension

** Gooseneck design, end-to-end dimension

(d) Ductile iron

(sw) Segmentally welded steel

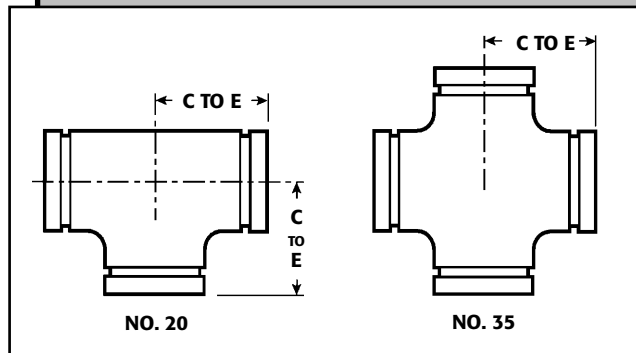
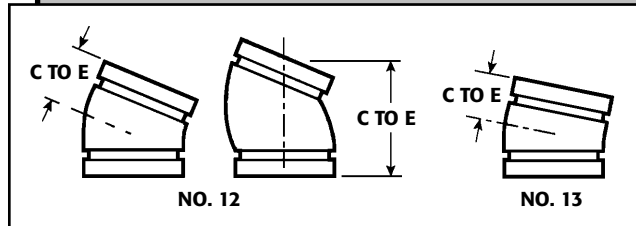
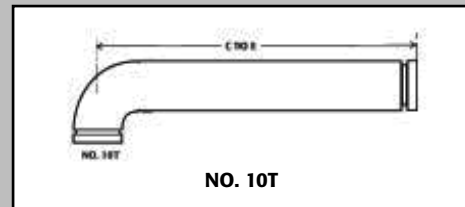
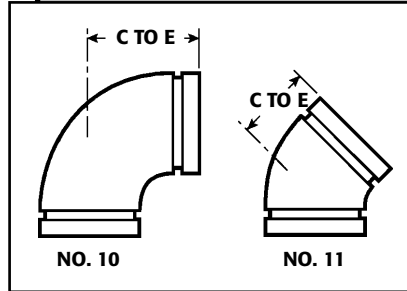

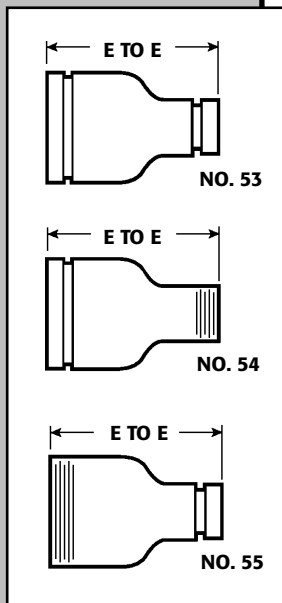
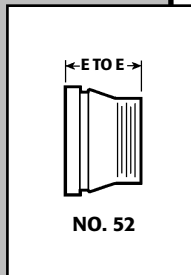
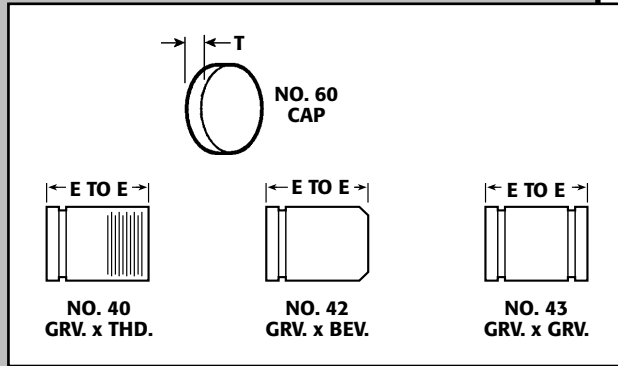

IPS Carbon Steel Pipe Grooved Fittings

Caps and Nipples (No. 60, 40, 42, 43)

Cap: Ductile Iron, Nipples: Steel

Nominal Size Inches (mm)	Thickness T Inches (mm)	No. 60 Cap**		No. 40, 42, 43 Nipple	
		Approx. Wgt. Ea. Lbs (kg)	E to E Inches (mm)	Approx. Wgt. Ea. Lbs (kg)	E to E Inches (mm)
3/4 (20)	0.88 (22)	0.2 (0.1)	3.00 (76)	0.3 (0.1)	3.00 (76)
1 (25)	0.88 (22)	0.3 (0.1)	3.00 (76)	0.4 (0.2)	3.00 (76)
1 1/4 (32)	0.88 (22)	0.3 (0.1)	4.00 (102)	0.8 (0.4)	4.00 (102)
1 1/2 (40)	0.88 (22)	0.5 (0.2)	4.00 (102)	0.9 (0.4)	4.00 (102)
2 (50)	0.88 (22)	0.6 (0.3)	4.00 (102)	1.2 (0.5)	4.00 (102)
2 1/2 (65)	0.88 (22)	1.0 (0.5)	4.00 (102)	1.9 (0.9)	4.00 (102)
3*	0.88 (22)	1.2 (0.5)	-	-	-
3 (80)	0.88 (22)	1.2 (0.5)	4.00 (102)	2.5 (1.1)	4.00 (102)

*O.D. Dimension
**No. 60 cap is not suitable for use in vacuum service with Style 72 or 750 couplings. No. 61 Bull Plugs should be used.

Reducer Threaded—Small End (No. 52)

Nominal Size Inches (mm)	E to E Inches (mm)	Approx. Wgt. Ea. Lbs (kg)
1 1/2 x 1 (40 x 25)	2.50 (64)	0.8 (0.4)
2 x 3/4 (50 x 20)	2.50 (64)	0.9 (0.4)
2 x 1 (50 x 25)	2.50 (64)	1.0 (0.5)
2 x 1 1/4 (50 x 32)	2.50 (64)	1.2 (0.5)
2 x 1 1/2 (50 x 40)	3.00 (76)	1.3 (0.6)
2 1/2 x 2 (65 x 50)	2.50 (64)	1.4 (0.6)
3 x 1 (80 x 25)	2.50 (64)	1.3 (0.6)
3 x 2 (80 x 50)	2.50 (64)	1.5 (0.7)
3 x 2 1/2 (80 x 65)	2.50 (64)	2.4 (1.1)

Available with British Standard Pipe Threads, specify "BSP" clearly on order.

Swaged Nipples (No. 53, 54, 55)

Nominal Size Inches (mm)	E to E		Approx. Wgt. Ea. Lbs (kg)
	Inches (mm)	Lbs (kg)	
2 x 1 (50 x 25)	6.50 (165)	2.0 (0.9)	
2 x 1 1/4 (50 x 32)	6.50 (165)	2.0 (0.9)	
2 x 1 1/2 (50 x 40)	6.50 (165)	2.0 (0.9)	
2 1/2 x 1 (65 x 25)	7.00 (178)	3.0 (1.4)	
2 1/2 x 1 1/4 (65 x 32)	7.00 (178)	3.0 (1.4)	
2 1/2 x 1 1/2 (65 x 40)	7.00 (178)	3.0 (1.4)	
2 1/2 x 2 (65 x 50)	7.00 (178)	3.0 (1.4)	
3 x 1 (80 x 25)	8.00 (203)	4.5 (2.0)	
3 x 1 1/4 (80 x 32)	8.00 (203)	4.5 (2.0)	
3 x 1 1/2 (80 x 40)	8.00 (203)	4.4 (2.0)	
3 x 2 (80 x 50)	8.00 (203)	4.5 (2.0)	
3 x 2 1/2 (80 x 65)	8.00 (203)	4.5 (2.0)	

Questions? Answers at...
(866) CED-ELEV • (866) 233-3538
www.cedlevator.com

IPS Carbon Steel Pipe Grooved Fittings

Concentric/Eccentric Reducers (No. 50, 51)

Steel (except as noted)

Nominal Size Inches (mm)	No. 50		No. 51	
	E to E Inches (mm)	Approx. Wgt. Ea. Lbs (kg)	E to E Inches (mm)	Approx. Wgt. Ea. Lbs (kg)
1 1/4 x 3/4 (32 x 20)	*	*	-	-
1 1/4 x 1 (32 x 25)	*	*	-	-
1 1/2 x 3/4 (40 x 20)	*	*	-	-
1 1/2 x 1 (40 x 25)	2.50 (64) d	0.8 (0.4)	8.50 (216)	4.5 (2.0)
1 1/2 x 1 1/4 (40 x 32)	*	*	-	-
2 x 3/4 (50 x 20)	2.50 (64) d	0.6 (0.3)	9.00 (229)	2.0 (0.9)
2 x 1 (50 x 25)	2.50 (65) d	0.7 (0.3)	9.00 (229)	2.3 (1.0)
2 x 1 1/4 (50 x 32)	2.50 (65) d	1.2 (0.5)	9.00 (229)	4.6 (2.1)
2 x 1 1/2 (50 x 40)	2.50 (64) d	1.1 (0.5)	9.00 (229)	4.6 (2.1)
2 1/2 x 1 (65 x 25)	9.50 (241)	3.3 (1.5)	9.50 (241)	3.3 (1.5)
2 1/2 x 1 1/4 (65 x 32)	9.50 (241)	3.6 (1.6)	9.50 (241)	*
2 1/2 x 1 1/2 (65 x 40)	9.50 (241)	3.6 (1.6)	9.50 (241)	3.6 (1.6)
2 1/2 x 2 (65 x 50)	2.50 (64) d	1.4 (0.6)	3.50 (89) d	1.6 (0.7)
3 x 1 (80 x 25)	2.50 (64) d	1.4 (0.6)	9.50 (241)	4.8 (2.2)
3 x 2 (80 x 50)	2.50 (64) d	1.6 (0.7)	3.50 (89) d	2.1 (1.0)
3 x 2 1/2 (80 x 65)	2.50 (64) d	1.8 (0.8)	3.50 (89) d	2.2 (1.0)

(d) Ductile iron.

Reducing Tees (No. 25, 29)

Segmentally Welded Steel (except as noted)

Nominal Size Inches (mm)	No. 25 Standard		No. 29 w/Thd. Branch	
	C to E Inches (mm)	Approx. Wgt. Ea. Lbs (kg)	C to E Inches (mm)	Approx. Wgt. Ea. Lbs (kg)
2 x 2 x 3/4 (50 x 50 x 20)	3.25 (83) d	2.5 (1.1)	3.25 (83) d	2.5 (1.1)
2 x 2 x 1 (50 x 50 x 25)	3.25 (83) d	2.3 (1.0)	3.25 (83) d	2.3 (1.0)
2 x 2 x 1 1/2 (50 x 50 x 40)	3.25 (83)	3.2 (1.5)	3.25 (83)	3.2 (1.5)
2 1/2 x 2 1/2 x 1 (65 x 65 x 25)	3.75 (95)	3.8 (1.7)	3.75 (95)	3.8 (1.7)
2 1/2 x 2 1/2 x 1 1/2 (65 x 65 x 40)	3.75 (95) d	4.0 (2.0)	3.75 (95) d	4.0 (2.0)
2 1/2 x 2 1/2 x 2 (65 x 65 x 50)	3.75 (95)	4.5 (2.0)	3.75 (95)	4.5 (2.0)
3 x 3 x 1 (80 x 80 x 25)	4.25 (108) d	6.5 (2.9)	4.25 (108) d	6.5 (2.9)
3 x 3 x 1 1/2 (80 x 80 x 40)	4.25 (108)	6.5 (2.9)	4.25 (108)	6.5 (2.9)
3 x 3 x 2 (80 x 80 x 50)	4.25 (108)	6.2 (2.8)	4.25 (108)	6.2 (2.8)
3 x 3 x 2 1/2 (80 x 80 x 65)	4.25 (108)	6.4 (2.9)	4.25 (108)	6.4 (2.9)

No. 29 Threaded Outlet Reducing Tees are supplied NPT and are available with British Standard threads. For British Standard specify "BSP" clearly on order.
(d) Ductile iron.

Pressure Gauge Shut Off Ball Valve

The Maxton Hydraulic Shut Off 1/8" Ball Valve has been tested specifically for hydraulic elevator applications. This bar-stock brass design with a double O-ring stem seal features a blow out proof stem and a metal retainer seal. Complies with ASME A17.1

Part Number	Description
BV1-8	1/8" male to male thread
BV1-4	1/4" male to female thread

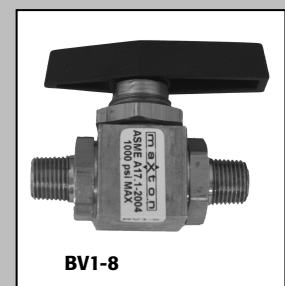
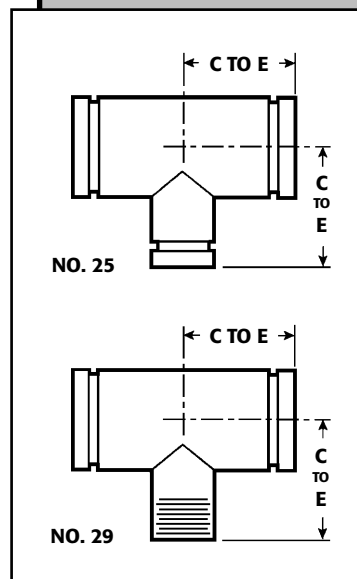
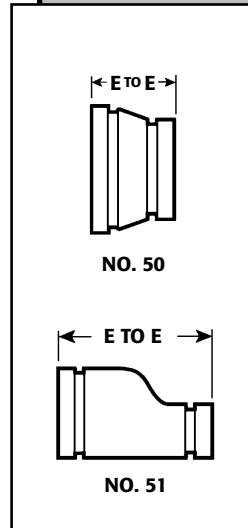

Questions? Answers at...
(866) CED-ELEV • (866) 233-3538
www.cedelevator.com

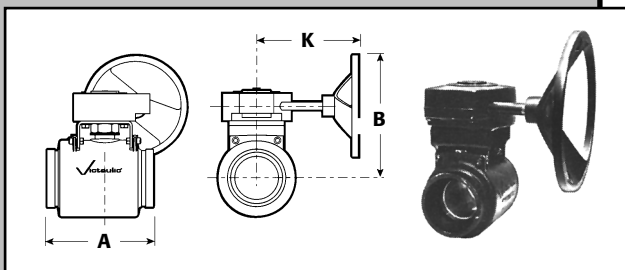
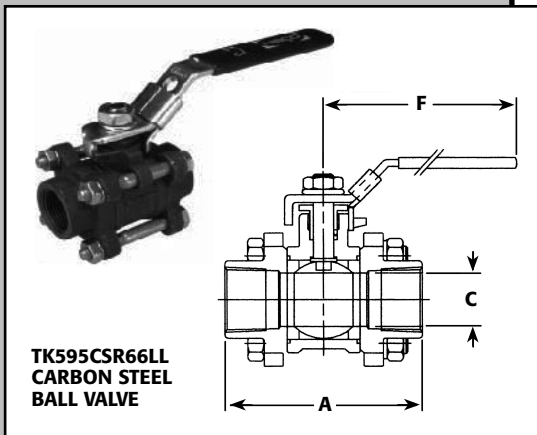
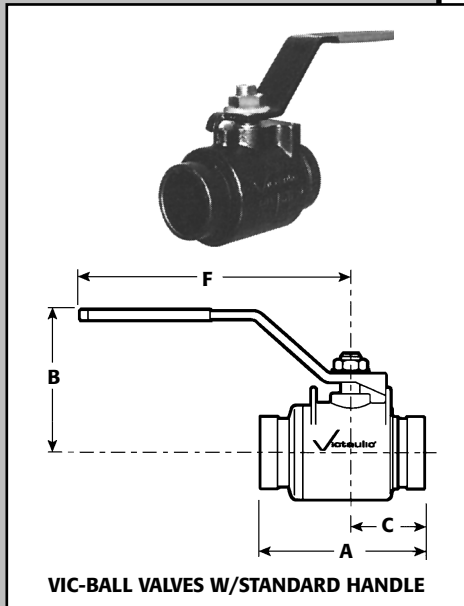

IPS Carbon Steel Pipe Grooved Valves

Vic-Ball® Valves [Series 726]

Vic-Ball valve is a standard port, end-entry valve designed for 1000 PSI (4130 kPa) WOG service. Valve body and end cap are ductile iron. Micro-finished steel ball and stem (316 stainless available), TFE seat streamlined design provides excellent flow characteristics. Vic-Ball valves are available with internal plastic coating or with a full stainless (316) body in 2, 2½, 3 and 4" (50, 65, 80 and 100 mm) sizes. Vic-Ball is available with standard manual handles or gear operators. A tamper resistant lock/seal option is available. For electric or pneumatic actuation, contact Victaulic. Pinned handle are available; contact Victaulic for details. Request 08.13.

Vic-Ball Valves with Standard Handle [Series 726]

Nom Size Inches (mm)	Dimensions - Inches (mm)				Approx. Wgt. Each Lbs (kg)
	E-E A	Hgt. B	C	F	
1½ (40)	5.00 (127)	2.53 (64)	2.32 (60)	7.13 (181)	5.0 (2.3)
2 (50)**	5.50 (140)	3.31 (84)	2.47 (63)	9.13 (232)	6.5 (2.9)
2½ (65)	6.30 (160)	3.68 (94)	2.82 (72)	9.13 (232)	10.5 (4.8)
3*	6.30 (160)	3.68 (94)	2.82 (72)	9.13 (232)	10.5 (4.8)
3 (80)**	6.71 (170)	3.87 (98)	3.03 (77)	9.13 (232)	13.5 (6.1)

*O.D. Dimension
** Stainless steel body also available.

3-Piece Carbon Steel Ball Valve [TK595CSR66LL]

Full port. Female threaded ends

Nom Size Inches (mm)	Dimensions - Inches (mm)				Approx. Wgt. Each Lbs (kg)
	E-E A	Hgt. B	C	F	
2 (50)	5.43 (138)	4.25 (108)	1.97 (50)	7.95 (202)	9.5 (4.32)

Vic-Ball Valves with Gear Operator [Series 726]

Nominal Size** Inches (mm)	Dimensions - Inches (mm)			Approx. Wgt. Each Lbs (kg)
	E-E A	Height B	K	
2 (50)	5.50 (140)	10.94 (278)	6.87 (175)	11.8 (5.4)
2½ (65)	6.30 (160)	10.88 (276)	6.87 (175)	15.6 (7.1)
3*	6.30 (160)	10.88 (276)	6.87 (175)	15.6 (7.1)
3 (80)	6.71 (170)	11.28 (287)	6.87 (175)	21.8 (9.9)

*O.D. Dimension
**1½ (40mm) sizes available.

Questions? Answers at...
(866) CED-ELEV • (866) 233-3538
www.cedlevator.com

IPS Carbon Steel Pipe Grooved Valves Steel Pipe Nipples & Fittings

Brass Body Ball Valve (Series 722)

Nom Size Inches (mm)	Dimensions - Inches (mm)				Approx. Wgt. Each Lbs (kg)
	E-E A	Hgt. B	C	F	
1/4 (8)	1.54 (39)	0.77 (20)	1.03 (26)	1.65 (42)	0.2 (0.09)
3/8 (10)	1.77 (45)	0.88 (22)	1.28 (33)	3.07 (78)	0.3 (0.14)
1/2 (15)*	2.13 (54)	1.06 (27)	1.33 (34)	3.07 (78)	0.4 (0.18)
3/4 (20)*	2.44 (62)	1.22 (31)	1.79 (45)	3.78 (96)	0.7 (0.32)
1 (25)*	2.95 (75)	1.48 (37)	1.95 (50)	3.78 (96)	1.0 (0.45)
1 1/4 (32)*	3.31 (84)	1.65 (42)	2.17 (55)	3.78 (96)	1.5 (0.68)
1 1/2 (40)*	3.66 (93)	1.83 (46)	2.68 (68)	5.43 (138)	2.1 (0.95)
2 (50)*	4.21 (107)	2.11 (53)	2.89 (73)	5.43 (138)	2.4 (1.09)

*UL Listed, FM Approved as noted in text above.

Forged Steel Fittings

- Available in 90s, 45s, couplings, reducing bushings and reducing couplings
- 3000psi, 3000lb. rated
- Sizes 2, 2.5 and 3-inch.

Black Hydraulic Piping

We are proud to offer Black Hydraulic Pipe in a variety of constructions and sizes. Schedule 40 and Schedule 80 available from 2-inch to 3-inch. Standard delivery is in 20-foot sections. We will cut to length! (Other sizes available upon request.)

See page 5.14 for Cush Clamps.

Rupture Valves (Blain)

The rupture valve is designed to allow an elevator to decelerate comfortably, bringing the elevator to a smooth stop in cases where the down speed exceeds allowable limits due to failure in a cylinder line and/or pre-set allowable limits.

The rupture valve can be mounted in any position directly onto the cylinder inlet.

We conveniently stock rupture valves in all sizes. We make it easy to install as we offer a standard female connection with an NPT taper (also available in grooved).

Line Size	GPM	L/Min	PSI	Bar
3/4"	1.3-20	5-100	1500	100
1"	27-45	101-175	1500	100
1 1/2"	46-110	176-425	1500	100
2"	111-208	426-800	1500	100
2 1/2"	209-318	801-1225	1500	100
3"	319-546	1226-2100	1500	100

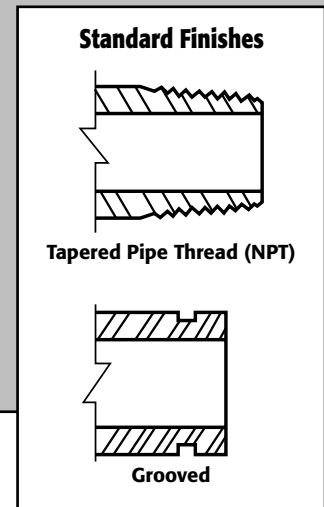
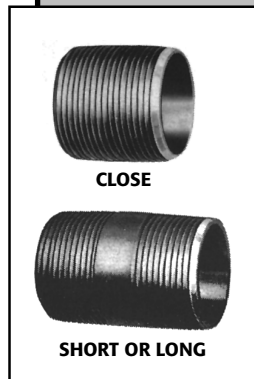
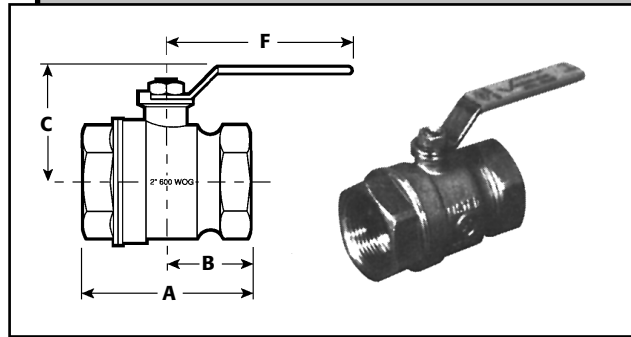

Identification

Where possible, each seamless pipe nipple is identified with the following:

- A trademark
- Seamless designation "SMLS"
- Pipe schedule STD or XS
- Material designation A106 B



Questions? Answers at...
 (866) CED-ELEV • (866) 233-3538
 www.cedelevator.com

MOTORS

In this Section

- Submersible Elevator Motors . . . 18.2
- DC Elevator Door Motor 18.2

Submersible Motors Door Motors

Submersible Elevator Motors

Part Number	Frame			Rated RPM	F.L.		1		1	Weight (lbs.)	
	Hz	60	[HP]		Torque	Voltage	Amps	Start			Wye-Delta
SB8/200					200	34.3	99.5	50.8	0.77	70	
SB8/230-460	SB150	8	16.4	3380	230	29.8	86.5	44.3	0.77	70	39.68
					460	14.9	43.4	22.1	0.77	70	
SB10.5/200					200	41.3	120	60.3	0.80	72	
SB10.5/230-460	SB150	10.5	21.7	3400	230	35.9	115.4	57.2	0.80	72	46.29
					460	18	53	26.3	0.80	72	
SB13/200					200	47.6	138	68.5	0.81	74	
SB13/230-460	SB150	13	26.7	3420	230	41.5	120.7	60	0.81	74	52.91
					460	20.7	63	29.8	0.81	74	
SB15/200					200	55.7	151.3	79	0.82	74	
SB15/230-460	SB200	15	30.2	3490	230	48.7	141	69.1	0.82	74	85.97
					460	24.5	73	34.4	0.82	74	
SB20/200					200	71.3	220	102	0.84	75	
SB20/230-460	SB200	20	41.1	3420	230	62.3	192	89.3	0.84	75	90.38
					460	31	92	44.3	0.84	75	
SB25/200					200	87.2	261	127	0.87	75	
SB25/230-460	SB200	25	51	3440	230	79	236	112.9	0.87	75	90.36
					460	37.9	109.9	54.2	0.87	75	
SB30/200					200	110.8	332	159.6	0.85	78	
SB30/230-460	SB200	30	61.6	3420	230	98	285	141.2	0.85	78	99.20
					460	49	140	70	0.85	78	
SB40/200					200	137	405	198.6	0.85	78	
SB40/230-460	SB200	40	80.5	3490	230	119	357	172	0.85	78	110.22
					460	60	182	87	0.85	78	
SB50/200					200	178.2	518	260	0.87	77	
SB50/230-460	SB250	50	101.2	3470	230	155	460	224.8	0.87	77	141.09
					460	78	230	113.2	0.87	77	
SB60/200					200	199.8	595	890	0.85	78	
SB60/230-460	SB250	60	122.2	3450	230	174	517	252	0.85	78	194.00
					460	87	254	134	0.85	78	
SB70/200					200	234	680	358	0.87	76	
SB70/230-460	SB250	70	143.8	3490	230	204	591	313	0.87	76	213.84
					460	102	296	157	0.87	76	



Features:

- Class F insulation
- 90 starts per hour
- Foot mounted
- In conformity with cCSAus standard
- All motors are suitable for Wye-Delta starting if reduced starting current is desired.



MTR-0008N

GAL DC Elevator Door Motor

Part Number	HP	Voltage	Description
MTR-0008N	1/8	230DC-PM	2 wires
MTR-0009N	1/4	230DC-PM	2 wires

Operator model: MOD, MODCT, MODCTA, MODCTL, MODCTLVF, MODHFL, MODL, MODLNYC, Retiring Cam (RC1)

MOTOR CONTROL & DISTRIBUTION

19

In this Section

Solid State Motor Starters . . .	19.2-3
Sprecher & Schuh Soft Starters	19.4
Bussman Power Module Switch	19.5
Heavy Duty Safety Switches. . . .	19.6
Lockout/Tagout Devices.	19.5
Replacement Contact Kits . .	19.6-13



Solid State Elevator Motor Starters

Application

The Siemens solid-state elevator starter consists of two main components: the solid-state starter and the fault contactor.

The solid-state starter provides current limit starting and overload protection for the elevator motor. The starter also monitors potential fault conditions: shorted SCR, overload, phase reversal, and loss of phase.

Should any of these conditions occur, the starter will turn off and the fault contactor will drop out. The fault contactor pulls in as soon as three phase power is applied to the starter. The contactor will remain in until three phase power is removed or a fault condition occurs.

Hydraulic Applications¹

Catalog Number	Figure	In-Line Current (A)	Wired "Inside-the-Delta"					Wired "In-Line" ²					
			200V (hp)	230V (hp)	400V (hp)	460V (hp)	575V (hp)	In-Line Current (A)	200V (hp)	230V (hp)	400V (hp)	460V (hp)	575V (hp)
72EG34AFP	1	22	5	7.5	10	15	-	-	-	-	-	-	
72GG34AFP	1	35	7.5	10	20	25	-	18	-	5	7.5	10	-
72HG34AFP	1	42	10	15	25	30	-	22	5	7.5	10	15	-
72JG34AFP	1	55	15	20	30	40	-	28	7.5	10	15	20	-
72KG34AFP	1	68	20	25	40	50	-	35	7.5	10	20	25	-
72LG34AFP	1	80	25	30	50	60	-	42	10	15	25	30	-
72MG34AFP	1	105	30	40	60	75	-	55	15	20	30	40	-
72NG34AFP	1	130	40	50	75	100	-	68	20	25	40	50	-
72PG34AFP	1	157	50	60	100	125	-	80	25	30	50	60	-
72EG35AFP	1	22	-	-	10	15	20	-	-	-	-	-	-
72GG35AFP	1	35	-	-	20	25	30	18	-	-	7.5	10	15
72HG35AFP	1	42	-	-	25	30	40	22	-	-	10	15	20
72JG35AFP	1	55	-	-	30	40	50	28	-	-	15	20	25
72KG35AFP	1	68	-	-	40	50	60	35	-	-	20	25	30
72LG35AFP	1	80	-	-	50	60	75	42	-	-	25	30	40
72MG35AFP	2	105	-	-	60	75	100	55	-	-	30	40	50
72NG35AFP	2	130	-	-	75	100	125	68	-	-	40	50	60
72PG35AFP	2	157	-	-	100	125	150	80	-	-	50	60	75

¹For traction applications, use the next highest rating in the Hydraulic table. For instance, a 10 HP, 230V, Inside-the-Delta, Traction application would require an elevator starter that is 15 HP in the Hydraulic table (72HE34AFP).

²Units are supplied from the factory with wiring for "Inside-the-Delta." Rewiring the unit for "In-Line" is simple and quick. Refer to the instruction manual.

*The Starts Per Hour rating is based the number of times the motor starts. Since the motor runs only on "up" calls, the Calls Per Hour rating is twice the Starts Per Hour rating. For applications requiring 120 Starts Per Hour (240 Calls Per Hour) on Hydraulic Elevators, use a starter sized to the next larger motor rating. For example, for a 120 Starts Per Hour rating on a 40 HP motor use a 50 HP rated Elevator Starter.

72GBD01 - REPLACEMENT LOGIC BOARD

- Easy to install
- No need to remove the whole starter, simply replace the logic board and you are up and running
- Fixes a majority of start failures
- Only one universal board so no matter which model calss 72g starter you have, the same board words for all
- Simply use the starter keypad to configure the replacement lovic board

Questions? Answers at...
 (866) CED-ELEV • (866) 233-3538
www.cedlevator.com

Solid State Elevator Motor Starters

Features

- Selectable Motor Off Delay
- Fault Contactor Monitors:
 - Overload
 - Shorted SCR
 - Phase Reversal
 - Loss of Phase
- For use on 6 or 12 Lead Wye-Delta Wound Motors and for 3 Lead Motors
- Normal Condition Indicators:
 - Normal Forward Phase
 - Control Power On
 - Motor Run
 - Motor Up to Speed
- Fault Condition Indicators:
 - Motor Overload
 - Shorted SCR
 - Single Phase
- Copper/aluminum lugs are supplied with all units as standard.

Electrical Data

Operating Frequency

60 Hz-Hp rated, 50 Hz-kW rated

Input Voltage

+/- 15% of nominal voltage

Operating Temperature

0°C to 50°C (32°F to 122°F)
 Derate 33% for each 10°C over 50°C to a maximum of 70°C

Overload Rating

Class 10–Solid-State Overload Relay,
 Less than 10 second trip @ 600%
 of must hold amps

Short Circuit Protection

Not provided: To be supplied by customer

Controller Duty Cycle Rating

Hydraulic Elevator Duty: 30% Duty Cycle –
 80 starts per hour* (160 calls per hour)
 Traction Elevator Duty: 95% Duty Cycle
 –10 starts per hour

Off Delay

Approximately ½ sec after removal of
 Motor Run signal when selected.
 Approximately 30 milliseconds when not
 selected

All diagram dimensions are in inches, and are for
 reference only, not for construction.

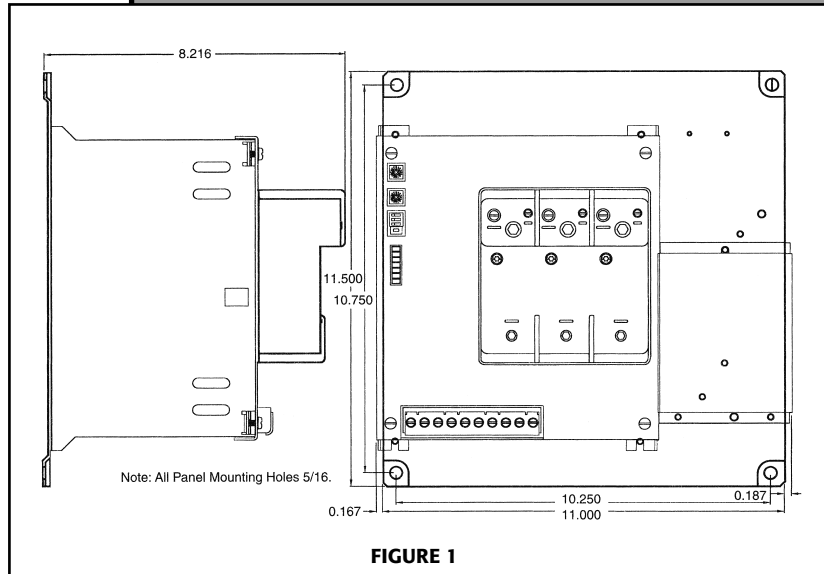

FIGURE 1

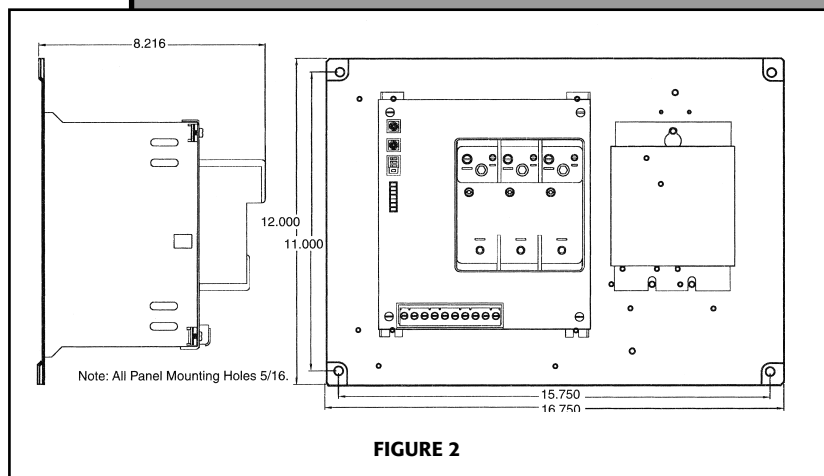
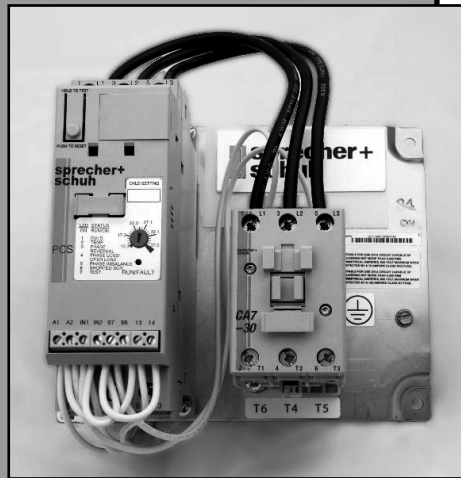

FIGURE 2



Sprecher & Schuh PCEC Hydraulic Elevator Softstarters

Thinking of replacing that old mechanical contactor with a softstarter but are concerned about it fitting... The PCEC is much smaller than other commonly used softstarters. It's the ideal wye-delta contactor replacement because it typically fits within the existing contactor footprint. The PCEC is supplied mounted to a back panel but the components will also snap on a DIN rail.

Diagnostics:

- Overload
- Over temp protection
- Phase reversal
- Phase loss/open Load
- Phase imbalance
- Shorted SCR
- Test overload

Features:

- Selectable overload class, 10, 15, 20, off
- Phase imbalance selectivity
- LED diagnostic & run display
- ½-sec "hold-in" display
- "Up-to-speed" contact

Elevator Softstarter

Part Number	DELTA Connected (6 Wire) H.P. Ratings				Overload Range (Amps)	LINE Connected (3 Wire) H.P. Ratings				Overload Range (Amps)
	3-PHASE 50/60 Hz					3-PHASE 50/60 Hz				
120VAC Control Voltage	208V	240V	480V	575V		208V	240V	480V	575V	
PCEC-032-600V-120V/230V	10	10	20	30	10.9...32.9	5	5	10	15	6.3...19
PCEC-051-600V-120V/230V	15	15	30	40	17.3...51.9	7.5	10	20	25	10...30
PCEC-064-600V-120V/230V	20	20	40	60	21...64	10	10	25	30	12.3...37
PCEC-074-600V-120V/230V	20	25	50	60	25...74	10	15	30	40	14.3...43
PCEC-104-600V-120V/230V	30	40	75	100	84.6...104	15	20	40	50	20...60
PCEC-147-600V-120V/230V	40	50	100	150	50...147	25	30	60	75	28.3...85
PCEC-234-600V-120V/230V	75	75	150	200	59...234	40	50	100	125	34...135

Replacement Parts

PCEC Assembly	PCE Controller Only	PCE Fans	Fault Contactor	Fault Contactor Coils*	
				120vac	208 - 240vac
PCEC-032-600V-120V	PCEC-032-600V		CA7-37-00-120		
PCEC-051-600V-120V	PCEC-051-600V		CA7-37-00-120	TC473	TC296
PCEC-064-600V-120V	PCEC-064-600V	PCV-064 (optional)	CA7-37-00-120		
PCEC-074-600V-120V	PCEC-074-600V		CA7-43-00-120	TD473	TD296
PCEC-104-600V-120V	PCEC-104-600V	PCV-147	CA7-60-00-120	TE473	TE296
PCEC-147-600V-120V	PCEC-147-600V		CA7-85-00-120	TE473	TE296
PCEC-234-600V-120V	PCEC-234-600V	PCV-234	CA6-180-EI-11-120	CA6-TGE865	CA6-TGE866

* The PCE controller's control voltage operating range is 100-240vac. The coil voltage of the fault contactor determines the control voltage of the PCEC assembly.

Dimensions

Controller Sizes	Units	Width	Height	Depth	Approx. Weight
32 / 51 / 64	mm	178	144	115.7	4 lbs
	inch	7.01	5.67	4.56	
74 / 104 / 147	mm	240	225	147.9	14 lbs
	inch	9.45	8.86	5.82	
234	mm	362	515	216.4	51 lbs
	inch	14.25	20.28	8.52	

Questions? Answers at...
(866) CED-ELEV • (866) 233-3538
www.cedlevator.com

Heavy Duty Safety Switches

UL (NEMA) Type 1

General Purpose

- Indoor use
- Heavy duty and general duty versions
- Made of code gauge steel given a rust-inhibiting treatment
- Provided with three- or four-point latching door
- Switches rated through 200 amperes provided with ample knockouts
- Switches rated 400 through 1200 amperes provided without knockouts
- Front-operated handles and narrow cover width to allow switches from 30 through 200 amperes to be mounted adjacent to one another
- 60-ampere heavy duty switch provided with a HUBBELLOCK®, Appleton or ARKTITE® interlocked receptacle to permit direct load/switch connection and disconnection
- Electrical interlock installable on heavy duty switches through 600 amperes



TYPE 1

UL (NEMA) Type 3R

Rainproof

- Outdoor use
- Available in ratings through 1200 amperes
- Made of galvanized sheet steel given a rust-inhibiting treatment. Gray electro-deposited enamel finish
- Top-hinged cover securable in the open position
- Factory-installed B-cap for immediate closure when no top conduit connection will be made
- Provisions for interchangeable bolt-on B-hubs that can be threaded onto conduit through the top endwall, eliminating the need for heavy conduit junctions
- Extruded lip on top endwall opening eliminates the need for gasketing to ensure tight closure
- Tangential openings for conduit eliminate need for offsets and bends
- Blank top endwalls on enclosures of switches rated above 200 amperes
- Enclosures of switches rated up to 200 amperes are provided with knockouts—below the level of the lowest live parts to maintain the integrity of the rainproof design
- Electrical interlock installable on heavy duty switches through 600 amperes

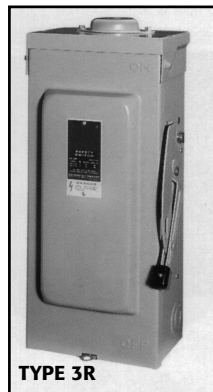

TYPE 3R

GENERAL DUTY 240V RATED NEMA 1

PART #	# OF POLES	AMPS
D221N	2	30
D321N	3	30
D322N	3	60
D323N	3	100

GENERAL DUTY 240V RATED NEMA 3R

PART #	# OF POLES	AMPS
D221NRB	2	30
D222NRB	2	50
D223NRB	2	100
D321NRB	3	30
D322NRB	3	60
D323NRB	3	100

HEAVY DUTY 240V RATED NEMA 1

PART #	# OF POLES	AMPS
H321N	3	30
H322N	3	60
H323N	3	100
H324N	3	200

HEAVY DUTY 600V RATED NEMA 1

PART #	# OF POLES	AMPS
H361	3	30
H362	3	60
H363	3	100
H364	3	200

HEAVY DUTY 600V RATED NEMA 3R

PART #	# OF POLES	AMPS
H361RB	3	30
H362RB	3	60
H363RB	3	100
H364RB	3	200

Lockout/Tagout Devices

Part Number	Description
IDEAL 44785	Cleat for 277V Breaker Lockout
IDEAL 44786	480/600V Lockout Switch
IDEAL 44789	Lockout (Wall Switch)
IDEAL 44800	Lockout (Hasps)
IDEAL 44807	480/600V Multi-Pole Breaker Lockout
IDEAL 44809	Universal 277V SP Breaker Lockout
IDEAL 44810	Hinged 1-Pole Breaker Lockout
IDEAL 44833	Lockout (Do Not Operate)
SQD 2510FL1	Lockout (Manual Starter/Switch Handle Guard)



Questions? Answers at...
 (866) CED-ELEV • (866) 233-3538
 www.cedelevator.com

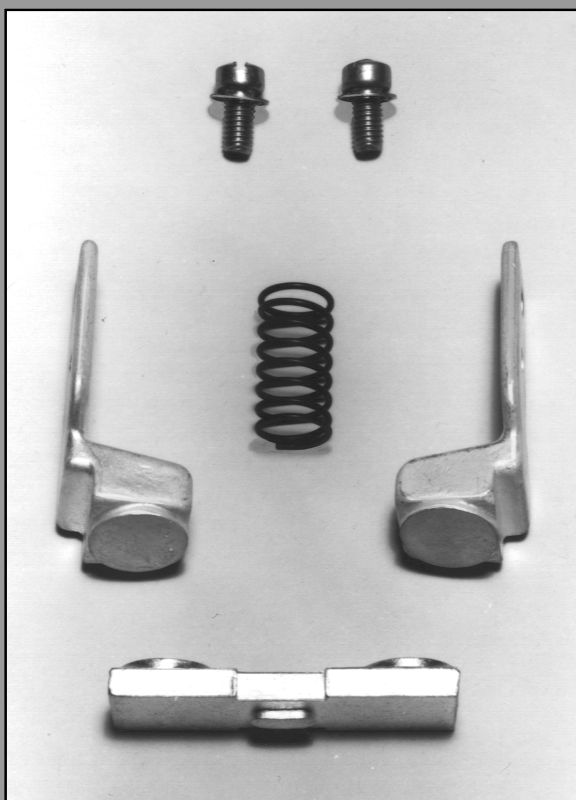
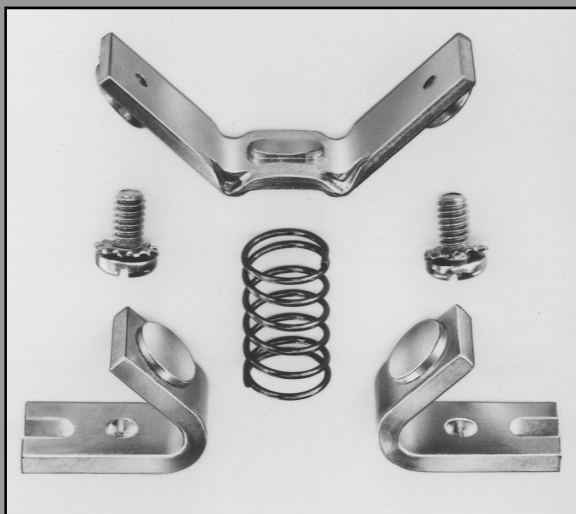

Certificate of Conformance

Hoyt Corporation certifies that its contacts are equal to OEM contacts in form, fit and function and meet or exceed our quality specifications of the OEM part. Hoyt further certifies that its contacts are being manufactured for the commercial market as an equivalent.

Replacement Contact Kits

CED is your source for quality, low cost replacement contact kits for the following manufacturers...

ASEA Brown Boveri	Allen Bradley	Arrow Hart
Cutler-Hammer	Federal Pacific	Furnas
General Electric	Joslyn-Clark	Siemens-Allis
Sprecher + Schuh	Square "D"	Ward Leonard
Westinghouse	Telemecanique (ITE/Gould)	

ABB — General Purpose

OEM Number	Replacement Number	Description
EG801 CK	9233CB	Size 3, 3 pole
EG80CK2P	K632	Size 3, 2 pole
EG1601CK	9243CB	Size 4, 3 pole
EG160CK2P	K642	Size 4, 2 pole
EG3151CK	9253CB	Size 5, 3 pole
EG315CK2P	K652	Size 5, 2 pole
EG60302CK	9263CB	Size 6, 3 pole
EG630CK2P	K662	Size 6, 2 pole
EG900CK	9273CB	Size 7, 3 pole

ABB — Drive Contactors

OEM Number	Replacement Number	Description
EFLG80CK	9333CB	110 amp, 3 pole
EFLG80CK2P	K932	110 amp, 2 pole
EFLG160CK	9343CB	180 amp, 3 pole
EFLG160CK2P	K942	180 amp, 2 pole
EFLG280CK2P	9353CB	280 amp, 3 pole
EFLG280CK	K952	280 amp, 2 pole
EFLG315CK	9363CB	360 amp, 3 pole
EFLG315CK2P	K962	360 amp, 2 pole
EFLG630CK	9373CB	535 amp, 3 pole
EFLG630CK2P	K972	535 amp, 2 pole

Allen-Bradley — Series K

OEM Number	Replacement Number	Description
Z21101	K156	Size 00, 2 pole
Z21102	K157	Size 00, 3 pole
Z21103	9194CA	Size 00, 4 pole
Z34037	9101CA	Size 0, 1 pole
Z34038	9111CA	Size 1, 1 pole
Z34039	9121CA	Size 2, 1 pole
Z34040	9131CA	Size 3, 1 pole
Z34041	9141CA	Size 4, 1 pole
Z34042	9151CA	Size 5, 1 pole
Z34043*	9351CA	Size 5, 1 pole

Replacement Contact Kits

Allen-Bradley — Series A

OEM Number	Replacement Number	Description	OEM Number	Replacement Number	Description
X33977	6802CA	Size 0, Short Stationary	X-36670	1012CA	Size 2, Movable
X35162	6801CA	Size 0, Long Stationary	X-36703	6806CA	Size 3, Stationary
X33553	1010CA	Size 0, Movable	X-36671	1013CA	Size 3, Movable
X33519	6804CA	Size 1 & 1P, Short Stationary	X-67541	6807CA	Size 4, Stationary
X35163	6803CA	Size 1 & 1P, Long Stationary	X-119624	1014CA	Size 4, Movable
X33552	1011CA	Size 1 & 1P, Movable	X-98909	6808CA	Size 5, Stationary
X36702	6805CA	Size 2, Stationary	X-104555	1015CA	Size 5, Movable

Aromat

OEM Number	Replacement Number	Description	OEM Number	Replacement Number	Description
BM6-35-901	9823CLX	Size 1++, 3 pole	BM6-85-901	9853CLX	Size 3+, 3 pole
BM6-50-901	9823CLX	Size 2+, 3 pole	BM6-125-901	9863CLX	Size 3++, 3 pole
BM6-65-901	9853CLX	Size 2++, 3 pole	BM-160-901	9883CLX	Size 4+, 3 pole
BM6-80-901	9853CLX	Size 3, 3 pole	BM6-190-901	9883CLX	Size 4++, 3 pole

Cutler-Hammer — Series A1

OEM Number	Replacement Number	Description	OEM Number	Replacement Number	Description
6-23	K705	Size 1, 2 pole	6-25-2	9133CC	Size 3, 3 pole
6-23-2	9113CC	Size 1, 3 pole	6-26	K730	Size 4, 2 pole
6-23-3	K707	Size 1, 4 pole	6-26-2	9143CC	Size 4, 3 pole
6-23-4	K708	Size 1, 5 pole	6-27	K735	Size 5, 2 pole
6-24	K710	Size 2, 2 pole	6-27-2	9153CC	Size 5, 3 pole
6-24-2	9123CC	Size 2, 3 pole	6-28	K738	Size 6 & 7, 2 pole
6-25	K720	Size 3, 2 pole	6-28-2	9163CC	Size 6 & 7, 3 pole

Cutler-Hammer — Series B1

OEM Number	Replacement Number	Description	OEM Number	Replacement Number	Description
6-34	K712	Size 2, 2 pole	6-35-2	9233CC	Size 3, 3 pole
6-34-2	9223CC	Size 2, 3 pole	6-36	K732	Size 4, 2 pole
6-34-3	K714	Size 2, 4 pole	6-36-2	9243CC	Size 4, 3 pole
6-34-4	K715	Size 2, 5 pole	6-36-3	K728*	Size 4, 2 pole
6-35	K722	Size 3, 2 pole	6-36-4	9243CC	Size 4, 3 pole

*Kits supplied without contact bar.

Cutler-Hammer — Freedom Series, IEC

OEM Number	Replacement Number	Description
6-65-4	9703CC	Size G, 3 pole
6-65-6	9893CC	Size H, 3 pole
6-65-8	9823CC	Size J, 3 pole
6-65-17	9713CC	Size K, 3 pole
6-43-4	9723CC	Size L, 3 pole
6-43-2	9833CC	Size M, 3 pole
6-43-6	9733CC	Size N, 3 pole

Freedom Series, NEMA

OEM Number	Replacement Number	Description
6-65-2	9813CC	Size 1, 3 pole
6-65-8	9823CC	Size 2, 3 pole
6-43-2	9833CC	Size 3, 3 pole
6-44-2	9843CC	Size 4, 3 pole
6-45-2	9853CC	Size 5, 3 pole

Questions? Answers at...
 (866) CED-ELEV • (866) 233-3538
www.cedlevator.com

Replacement Contact Kits

Furnas — Innova 45 Series

OEM Number	Replacement Number	Description
75DF14	9210CF	Size 1, 1 pole
75EF14	9215CF	Size 1¾, 1 pole
75FF14	9220CF	Size 2, 1 pole
75FP14	9320CF	Size 2, 1 pole
75GF14	9225CF	Size 2½, 1 pole
75GP14	9325CF	Size 2½, 1 pole
75HF14	9230CF	Size 3, 1 pole
75IF14	9235CF	Size 3½, 1 pole

General Electric — 100, 200 & 300 Line

OEM Number	Replacement Number	Description
232A6724G009	K430	Size 6, 3 pole
232A6724G011	K435	Size 6, 2 pole
546A300G002	K420	Size 0, 4 pole
546A300G010	K420	Size 0, 4 pole
546A301G002	K425	Size 1, 4 pole
546A301G053	K425	Size 1, 4 pole
546A780G002	K420	Size 2, 3 pole

General Electric — Spectra 700 series

OEM Number	Replacement Number	Description
CR7XDG	9313CG	3 Pole, 37 amp, CR7CG
CR7XDH	9313CG	3 Pole, 45 amp, CR7CH
CR7XDJ	9323CG	3 Pole, 56 amp, CR7CJ
CR7XDK	9323CG	3 Pole, 73 amp, CR7CK
CA5F2CPR1	9333CG	3 Pole, 105 amp, CA5F2

Joslyn Clark — Sylvania, CY Series

OEM Number	Replacement Number	Description
CY-31-1	9413CD	Size 1, 3 pole
CY-32-1	9423CD	Size 2, 3 pole
CY-33-1	9433CD	Size 3, 3 pole
CY-34-1	9443CD	Size 4, 3 pole
CY-43-1	K116	Size 3, 4 pole
CY-44-1	K121	Size 4, 4 pole

Mitsubishi

OEM Number	Replacement Number	Description
BH509301	n/a	3 Pole, S-K10
BH509N301	n/a	3 Pole, S-K11
BH519N304	n/a	3 Pole, S(D)K10, S-K12
BH529N301	9143CX	3 Pole, S-K18, K19
BH539N300	9203CX	3 Pole, BH539N300 S(D)K13
BH549N300	9113CX	3 Pole, S-K25
BH549N301	9213CS	3 Pole, S(D)K35

Furnas — Model B

OEM Number	Replacement Number	Description
75FB14A	9120CF	Size 2, 1 pole
75GB14	9125CF	Size 2½, 1 pole
75HB14	9130CF	Size 3, 1 pole
75IB14	9135CF	Size 3½, 1 pole
75JB14	9140CF	Size 4, 1 pole
75RB14	9145CF	Size 4½, 1 pole
75KB14	9150CF	Size 5, 1 pole

OEM Number	Replacement Number	Description
546A78G2/G51	9723CG	Size 2, 3 pole
55153677G001	K403	Size 3, 1 pole
55-153677G2	9733CG	Size 3, 3 pole
55-153678G2	9743CG	Size 4, 3 pole
55-154607G2	9753CG	Size 5, 3 pole
55-154607G2/G41	9753CG	Size 5, 3 pole
55-186556G4	9753CGA	Size 6, 3 pole

ITE — Gould

OEM Number	Replacement Number	Description
G203C	K351	Size 1 & 1P, 3 pole
G203D	K352	Size 2, 3 pole
G203E	K353	Size 3, 3 pole
G203F	K354	Size 4, 3 pole
G203G	K355	Size 5, 3 pole

Clark, TM Series

OEM Number	Replacement Number	Description
KTM25-1	K785	Size 5, 2 pole
KTM31-1	9583CD	Size 00, 0 & 1, 3 pole
KTM32-1	9523CD	Size 1P & 2, 3 pole
KTM33-1	9533CD	Size 3, 3 pole
KTM34-1	9543CD	Size 4, 3 pole
KTM35-1	9553CD	Size 5, 3 pole

OEM Number	Replacement Number	Description
BH569N301	9163CX	3 Pole, S-K95
BH569N302	9253CX	3 Pole, SD-K80
BH569N303	9263CX	3 Pole, SD-K95
BH579N301	9173CX	3 Pole, S-K125
BH579N304	n/a	3 Pole, 9273CX
BH589N300	n/a	3 Pole, 9373CX
BH599N300	n/a	3 Pole, 9283CX

Questions? Answers at...
 (866) CED-ELEV • (866) 233-3538
www.cedlevator.com

Replacement Contact Kits

Mitsubishi (cont.)

OEM Number	Replacement Number	Description	OEM Number	Replacement Number	Description
BH559N301	9243CX	3 Pole, S-K65	BH599N300	n/a	3 Pole, S(D)K220
BH559N302	9233CX	3 Pole, SD-K50	BH599N301	n/a	3 Pole, 9183CX
BH559N303	9243CX	3 Pole, SD-K65	BH609N300	n/a	3 Pole, 9193CX
BH559N306	9123CX	3 Pole, S-K38	BH609N301	n/a	3 Pole, 9293CX
BH559N307	9223CX	3 Pole, S-K48	BH619N300	n/a	3 Pole, 9383CX
BH569N300	9153CX	3 Pole, S-K80	BH619N301	n/a	3 Pole, 9393CX

Siemens-Allis — Value Line

OEM Number	Replacement Number	Description	OEM Number	Replacement Number	Description
25-106-921-812	9114CV	Size 1, 4 Pole	14-124-454-001	n/a	Size 4+, 1 Pole
25-106-922-812	9123CV	Size 2, 3 Pole	14-125-864-001	n/a	Size 5, 1 Pole
25-106-923-812	9133CV	Size 3, 3 Pole	14-133-172-001	n/a	Size 6, 1 pole
25-106-924-812	9143CV	Size 4, 3 Pole			

Siemens-Allis — World Series — AC Contactors

OEM Number	Replacement Number	Description	OEM Number	Replacement Number	Description
3TY6440-OA	9503CV	Size 1, 3 Pole, 3TB Series	3TY7470-OA	9723CV	Size 2½, 3 Pole, 3TF Series
3TY6460-OA	9513CV	Size 2, 3 Pole, 3TB Series	3TY7480-OA	9733CV	Size 3, 3 Pole, 3TF Series
3TY6470-OA	9523CV	Size 2½, 3 Pole, 3TB Series	3TY7500-OA	9743CV	Size 3½, 3 Pole, 3TF Series
3TY6480-OA	9533CV	Size 3, 3 Pole, 3TB Series	3TY7520-OA	9753CV	Size 4, 3 Pole, 3TF Series
3TY6500-OA	9543CV	Size 3½, 3 Pole, 3TB Series	3TY7520-OB	n/a	Size 4, 3 Pole, 3TF Series
3TY6520-OA	9553CV	Size 4, 3 Pole, 3TB Series	3TY7540-OA	9763CV	Size 4½, 3 Pole, 3TF Series
3TY6540-OA	9563CV	Size 4½, 3 Pole, 3TB Series	3TY7540-OB	n/a	Size 4½, 3 Pole, 3TF Series
3TY6560-OA	9573CV	Size 5, 3 Pole, 3TB Series	3TY7560-OA	9733CV	Size 5, 3 Pole, 3TF Series
3TY6580-OA	9583CV	Size 6, 3 Pole, 3TB Series	3TY7560-OB	n/a	Size 5, 3 Pole, 3TF Series
3TY7440-OA	9703CV	Size 1, 3 Pole, 3TF Series	3TY7580-OA	9883CV	Size 6, 3 Pole, 3TF Series
3TY7460-OA	9713CV	Size 2, 3 Pole, 3TF Series			

* Kits supplied with all hardware except elastic spring retainer

Sprecher & Schuh

OEM Number	Replacement Number	Description	OEM Number	Replacement Number	Description
22.102.217-03	n/a	Sizes 0 & 00, 3 Pole, CA1-10	22.105.212-03	9243CR	Size 4½, 3 Pole, CA1-150
22.109.212-02	9113CR	Sizes 1 & 1¼, 3 Pole, CA1-14 & 16	22.106.212-02	9153CR	Size 5, 3 Pole, CA1-250
22.110.212-02	9123CR	Size 2, 3 Pole, CA1-25	22.701.214-01	9403CR	Size 1, 3 Pole, CA3-37
22.114.212-02	9223CR	Size 2½, 3 Pole, CA1-40	22.701.215-01	9413CR	Size 2, 3 Pole, CA3-43
22.104.212-04	9133CR	Size 3 & 3½, 3 Pole, CA1-55/60	22.701.216-01	9423CR	Size 2½, 3 Pole, CA3-60
22.104.212-06	9143CR	Size 4, 3 Pole, CA1-100	22.701.217-01	9433CR	Size 2¾, 3 Pole, CA3-72

CA5 CONTACTS

OEM Number	Replacement Number	Description
CA5-CP550	9251CR	CA5-550
CA5-CP700	9261CR	CA5-700
CA5-CP860	9270CR	CA5-860

Questions? Answers at...
 (866) CED-ELEV • (866) 233-3538
www.cedlevator.com

Replacement Contact Kits

CA7 CONTACTS

Replacement Number	Description
9543CR	CA7-30/37/43
9563CR	CA7-60/72
9563CR	CA7/85

Square D — Class 9998

OEM Number	Replacement Number	Description	OEM Number	Replacement Number	Description
HA-81	9563CS	Size 6, 3 pole	SL-9	9743CS	Size 4, 3 pole
HA-82	9663CS	Size 6, 3 pole	SL-10	K550	Size 5, 2 pole
JA-81	9673CS	Size 7, 3 pole	KA-81	9683CS	Size 8, 3 pole
HC-1	9948CS	Size 1, 2 pole	SL-11	9753CS	Size 5, 3 pole
HD-1	9941CS	Size 2, 2 pole	SL-12	K506	Size 00 & 0, 4 pole
HE-1	9951CS	Size 3, 2 pole	SL-13	K515	Size 1, 4 pole
HF-1	9952CS	Size 4, 2 pole	SL-14	K525	Size 2, 4 pole
HG-1	9953CS	Size 5, 2 pole	CA81	9613CS	Size 1, 3 pole
HH-1	9954CS	Size 6, 1 pole	CA82	K514	Size 1, 4 pole
SL-2	9703CS	Size 00 & 0, 3 pole	SA81	9513CS	Size 1, 3 pole
SL-3	9713CS	Size 1 & 1P, 3 pole	SA82	K513	Size 1, 4 pole
SL-4	9723CS	Size 2, 3 pole	TA81	9623CS	Size 2, 3 pole
SL-6	K530	Size 3, 2 pole	TA82	K524	Size 2, 4 pole
SL-7	9733CS	Size 3, 3 pole	UA81	9633CS	Size 3, 3 pole
SL-8	K540	Size 4, 2 pole			

Telemecanique

OEM Number	Replacement Number	Description	OEM Number	Replacement Number	Description
G203C	9813CT	Size 1, 3 Pole, Gould/ITE	LA5-FG431	9423CN	3 Pole, LC1F185 Series
G203D	9823CT	Size 2, 3 Pole, Gould/ITE	LA5-FH431	9433CN	3 Pole, LC1F265 Series
G203E	9833CT	Size 3, 3 Pole, Gould/ITE	LA5-FJ431	9453CN	3 Pole, LC1FJ43 Series, 300 amp
G203F	9843CT	Size 4, 3 Pole, Gould/ITE	LA5-FK431	9463CN	3 Pole, LC1FK43 Series, 540 amp
G203G	9853CT	Size 5, 3 Pole, Gould/ITE	LA5-FL431	9473CN	3 Pole, LC1FL43 Series, 900 amp
LA5-FF431	9413CN	3 Pole, LC1F115-F150 Series	LA5-F400803	9453CN	3 Pole, LC1F330-F400 Series

Ward Leonard — Series 5000 DP, 5999, 7400, 5950, 5960

OEM Number	Replacement Number	Description	OEM Number	Replacement Number	Description
5M45	9150CY	Size 5, 1 pole	5M53	9130CY	Size 3, 1 pole
5M49	9134CY	Size 3 & 4, 1 pole	5M54	9130CY	Size 4, 1 pole
5M52	9120CY	Size 2, 1 pole	5M56	9145CY	Size 4½, 1 pole

Questions? Answers at...
 (866) CED-ELEV • (866) 233-3538
www.cedlevator.com

Replacement Contact Kits

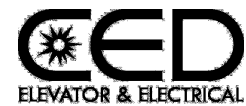

Westinghouse — Type A200, N & NF, Ampgard, M & MD, APC

OEM Number	Replacement Number	Description	OEM Number	Replacement Number	Description
1605202	9123CW	Size 2, 3 pole	373B331G11	9222CW	Size 2, 2 pole
1605212	9113CW	Size 1, 3 pole	373B331G12	9223CW	Size 2, 3 pole
1620145	9152CW	Size 5, 2 pole	373B331G13	9224CW	Size 2, 4 pole
1620146	9153CW	Size 5, 3 pole	373B331G14	9225CW	Size 2, 5 pole
1625563	9133CW	Size 3, 3 pole	373B331G18	9294CW	Size 00, 4 pole
1625564	9143CW	Size 4, 3 pole	461A757G17	9271CW	Size 7, 1 pole
180C180G01	K127	35 amp, 2 pole	477B477G01	K001	Size 5, 1 pole
180C180G02	9503CW	35 amp, 3 pole	477B477G03	K006	Size 5, 1 pole
180C180G05	K129	100 amp, 2 pole	477B477G05	9251CW	Size 5, 1 pole
180C180G06	9513CW	100 amp, 3 pole	477B477G06	K120	Size 5, 1 pole
2066A10G11	9261CW	Size 6, 1 pole	5250C81G01	K124	Size 4, 2 pole
2147A22G01	9643CW	200 amp, 3 pole	5250C81G16	K124	Size 4, 2 pole
2147A42G01	9663CW	400 amp, 3 pole	5250C81G02	K125	Size 4, 3 pole
2147A72G01	9673CW	700 amp, 3 pole	5250C81G17	9943CW	Size 4, 3 pole
2147A72G02	9673CW	700 amp, 3 pole H.D.	626B187G12	9232CW	Size 3, 3 pole
217A700G15	9761CW	Size 6, 1 pole	626B187G13	9233CW	Size 3, 3 pole
2184A10G14	9521CW	10/150 amp, 1 pole	626B187G14	9234CW	Size 3, 4 pole
26D2610G14	9401CW	100/150 amp, 1 pole	626B187G15	9235CW	Size 3, 5 pole
26D2610G15	9411CW	300 amp, 1 pole	626B187G16	9242CW	Size 4, 2 pole
26D2610G16	9421CW	900 amp, 1 pole	626B187G17	9243CW	Size 4, 3 pole
26D2610G18	9431CW	1350 amp, 1 pole	626B187G18	9244CW	Size 4, 4 pole
26D2610G19	9481CW	1350 amp, 1 pole	626B187G19	9245CW	Size 4, 5 pole
26D2610G20	9441CW	2500 amp, 1 pole	646C829G05	9281CW	Size 8, 1 pole
26D2610G21	9451CW	100/150 amp, 1 pole	672B788G03	K081	Size 2½, 5 pole
26D2610G22	9461CW	300 amp, 1 pole	672B788G09	9703CW	Size 2½, 3 pole
26D2610G23	9471CW	900 amp, 1 pole	672B839G01	K077	250 amp, 2 pole DP Model A
26D2610G24	9771CW	900 amp, 1 pole	672B839G02	K079	250 amp, 3 pole DP Model A
373B331G04	9204CW	Size 0, 4 pole	672B839G21	K075	250 amp, 2 pole DP Model B
373B331G07	9212CW	Size 1, 2 pole	672B839G22	K126	250 amp, 3 pole DP Model B
373B331G09	9214CW	Size 1, 4 pole			

Questions? Answers at...
 (866) CED-ELEV • (866) 233-3538
www.cedlevator.com

**MOTOR
GENERATOR
FILTERS**

In this Section

Motor Generator Filters 20.2-3

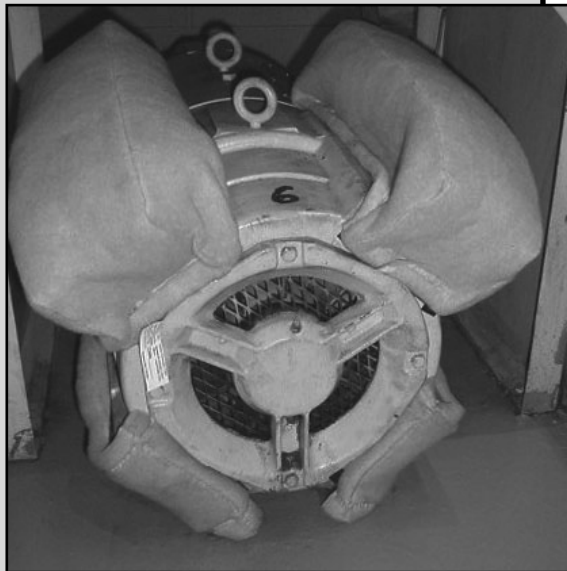

NEW CLEAN INSTALLATION (IMPERIAL 366)



AFTER 6 WEEKS, WITH NORMAL BRUSH WEAR

Motor Generator Filters

*"A simple, cost-effective solution
to a complicated problem"*

Eliminate expensive carbon dust cleanup

These filters eliminate the need for carbon dust cleanup, and help to promote customer satisfaction.

Cut down on call backs

Many of the callbacks for circuit board failure and leveling problems are due to shorts or fouling by carbon dust.

No heat build-up

All Sanders Filters have been designed to operate with zero temperature increase, even fully loaded.

Self extinguishing

These filters have passed a #302 automotive test for flammability.

Complete system

Sanders, Inc. offers 105 different filters systems designed specifically for each motor generator frame size and configuration, in conjunction with the two largest elevator manufacturers. These systems are specified as OEM parts and are currently in use in their service contracts. These Carbon Dust Filtration Systems have had thousands of successful installations over the last 10 years.

Problem:

As brushes wear, MG sets exhaust residual carbon from the process. The original designs of the MG sets did not account for this exhausting and made no provision for it. MG sets from all the major manufacturers have a fixed armature speed and fan curve designed to the cool the MG set, without any restriction of the airflow.

Carbon dust is made up of very small particles that can permeate circuit boards, shorting them out, foul 440 contacts, causing call backs due to leveling problems in elevators, and migrate through HVAC systems to adjacent areas of the building on the same system. In order to source-capture the carbon before it contaminates the adjacent area, a filter is required that traps the particles but does not restrict the cooling air, thereby overheating the MG set.

Solution:

The Sanders Carbon Dust Filtration System uses an extended surface cube that allows air to pass through without restriction, as if the filter wasn't even there. All filters have been individually designed, tested and thermo-scanned during normal use to insure a zero temperature increase, fully loaded with carbon dust.*

The complete system includes a custom designed set of filters and a bag for blowing out the carbon dust from the MG set before installing the filters.

*Follow manufacturer's recommended change schedule, average 3 months.

Design:

All Sanders motor generator filters are heat-sealed, creating a plastic stay that assures the filters will hold their shape, allowing for proper airflow without overheating the MG set. All are tagged to record installation date and the recommended change schedule. Sanders has identified 137 different motor generator frames, and is continually adding new sets. **If you do not see the MG set you need listed, please contact CED.**

Product Listing by Frame Number

Dover

Part Number	Filter(s)
D2500AC	1 cube
D2500DC	1 cube
D3500AC	1 cube
D3500DC	1 cube
D750	4 cubes
D36504	1 cube

General Electric

Part Number	Filter(s)
95	4 cubes, 1 panel

Imperial

Part Number	Filter(s)
I280T	2 cubes, 2 panels
I284A	2 cubes, 2 panels
I286A	2 cubes, 2 panels
I320T	2 cubes, 2 panels
I324T	2 cubes, 2 panels
I326	2 cubes, 2 panels
I360T	2 cubes, 2 panels
I365	2 cubes
I366	2 cubes, 2 panels
I367T	2 cubes
I368	2 cubes, 2 panels
I407A	2 cubes
I409A	2 cubes
ID37YT	2 cubes

Leroy Summers

Part Number	Filter(s)
LS46	wrist band
LS64	wrist band
LS280	wrist band
LS375	wrist band
LS500	wrist band
LS50 rev	1 end cube
LS57 rev	1 end cube

Otis

Part Number	Filter(s)
O71	1 cube
O82	1 cube
O95	1 crescent cube
O115	1 cube

Westinghouse

Part Number	Filter(s)
W44	4 cubes
W44BH	4 cubes
W45	4 cubes
W46	1 wrist band
W63A	4 cubes
W63AH	4 cubes
W63AY	4 cubes
W63.9	4 cubes
W63-9A	4 cubes
W66-9A	4 cubes
W64	1 wrist band
W64AY	4 cubes
W113-7.5	4 cubes
W113-10.5	4 cubes
W123	4 cubes
W143	4 cubes
W153	4 cubes
W286A	4 cubes, 1 panel
W405	4 cubes
W444	4 cubes, 1 panel
W444L	4 cubes, 1 panel
W444A	4 cubes, 1 panel
W587	4 cubes, 1 panel
W685A	4 cubes, 1 panel
W2810A	4 cubes, 1 panel
W360-9	1 wrist band
W3609L	1 wrist band
W3609.5	4 cubes, 1 panel
W3609A	4 cubes, 1 panel
W5010A	4 cubes, 1 panel
W5012A	4 cubes, 1 panel
W5014A	4 cubes, 1 panel

Westinghouse Exciters

Part Number	Filter(s)
W256E	4 cubes, 1 panel
W444E	4 cubes, 1 panel
W3609E	4 cubes, 1 panel

All Styles

Part Number	Filter(s)
Small Bag	B15
Medium Bag	B18
Large Bag	B40
Velcro	V 25'

MUFFLERS & COUPLINGS

In This Section

Mufflers	21.2
Smaller Diameter Mufflers	21.2
Isolation Coupling	21.2
Isolation Pad	21.2
MEI Silencers	21.3

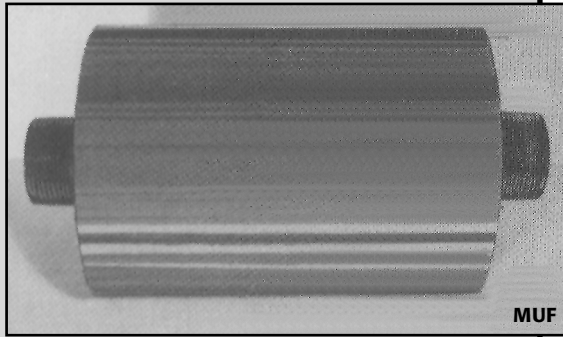

MUF



MUFS



ISC2G



CALDY1



CALDY2

Mufflers & Couplings

Mufflers

Quality mufflers operate with maximum efficiency to minimize noise under all conditions. Easily installed, quality construction with maintenance-free operation.

- Dimensions: 8 $\frac{5}{8}$ "D x 18" O.A.L. Weight: 58 lbs.

Part Number	Description
MUF-2G	2" grooved
MUF-2.5G	2½" grooved
MUF-3G	3" grooved
MUF-1.5	1½" threaded
MUF-2	2" threaded
MUF-2.5	2½" threaded
MUF-3	3" threaded

Smaller Diameter Mufflers

Lighter weight. Composed of sound deadening compound with a compression-resistant core.

Part Number	Description	Dimensions	Weight
MUFS-2G	2" grooved	4"D x 20" O.A.L.	25 lbs.
MUFS-2.5G	2½" grooved	4"D x 20" O.A.L.	25 lbs.
MUFS-3G	3" grooved	6"D x 20" O.A.L.	40 lbs.
MUFS-2	2" threaded	4"D x 20" O.A.L.	25 lbs.
MUFS-2.5	2½" threaded	4"D x 20" O.A.L.	25 lbs.
MUFS-3	3" threaded	6"D x 20" O.A.L.	40 lbs.

Isolation Coupling

- Reduces mechanically transmitted noise between power unit and car
- Use with muffler for maximum sound reduction
- Dielectric strength of 25 KV

Part Number	Description
ISC2G	2" grooved ends
ISC2.5G	2½" grooved ends
ISC3G	3" grooved ends
ISC4G	4" grooved ends

Isolation Pads

Part Number	Description
CALDY1	6"x18"x1/4" Ribbed Pads
CALDY2	6"x24"x1/2" Waffle Pads

Questions? Answers at...
 (866) CED-ELEV • (866) 233-3538
www.cedlevator.com

MEI Silencers

EXTEND THE LIFE OF YOUR HYDRAULIC ELEVATOR SYSTEM!

The MEI Silencer is an in-line device that reduces the noise and vibration of any hydraulic power unit (similar to the muffler on an automobile).

REDUCED PULSATIONS = REDUCED NOISE, LEAKAGE, AND COMPONENT WEAR.

Pump pulsations cause vibrations. Transmitted by the piping throughout the system, vibrations cause noise, leakage, and early component failure. When the MEI Silencer stops the pulsations, it stops the source of the vibrations. This improves system performance and reduces service calls, pleasing your client and improving your reputation.

BENEFITS

- 40-60% reduction in system noise and vibration
- Extended component life
- Fewer leaks
- Lower long-term system maintenance costs
- Smoother system operation

HOW IT WORKS

Hydraulic pulsations (noise) enter the silencer and go through three different noise baffles or diffusers. After passing through these baffles, the pulsations then strike a rubber tube, or bladder, charged with air to 35% to 50% of the hydraulic operating pressure. Hit by a pulsation, the bladder deflects slightly, reducing the size of the pulsation and therefore, the noise.

RECOMMENDED APPLICATIONS

- Dry or submersible hydraulic power units for all hydraulic elevator car types.

Part Number	Description	A	B	C
19316	Silencer 2" GRV x 2" GRV (100 max. GPM)	13 1/4"	1 1/4" TYP	3 7/8"
19317	Silencer 2" GRV x 2" GRV (220 max. GPM)	13 1/4"	1 1/4" TYP	4 5/8"
19318	Silencer 2 1/2" GRV x 2 1/2" GRV (325 max. GPM)	13 1/4"	1 1/4" TYP	4 5/8"
19319	Silencer 3" GRV x 2 1/2" GRV (360 max. GPM)	13 1/4"	1 1/4" TYP	4 5/8"
19315	Valve Stem Retrofit Kit			

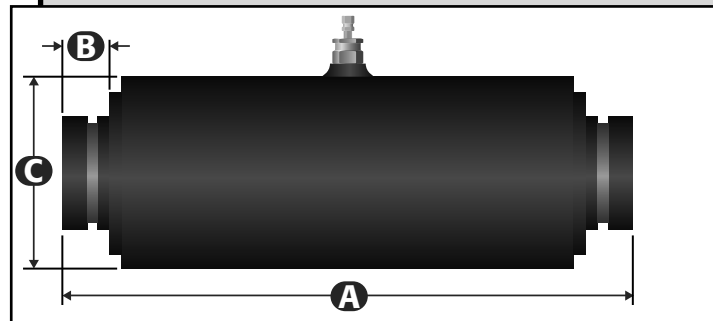
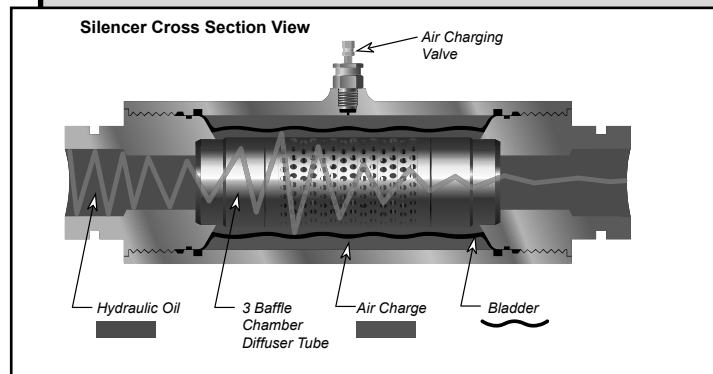

Questions? Answers at...
 (866) CED-ELEV • (866) 233-3538
 www.cedelevator.com

PACKINGS & SEALS

22

Cylinder Heads & Packing Sets

American Crescent	22.2
Amtech; Armor	22.3
Bore-Max; Canton	22.4
Cemco	22.5
Coast; Concord	22.6
Dover (Thyssenkrupp)	22.6-7
EECO	22.8-10
Elevator Manufacturing	22.10
Esco	22.11-12
Federal; Florlift; GCE	22.13
General	22.14
Global; Globe Hoist	22.15
Hollister-Whitney	22.15-16
Home; Hydromoris	22.16
Inclinor; ITI; Lift-Avator	22.17-18
Marmac; Montgomery	22.19-20
Mowrey; Northern	22.20-21
Oil-Lift	22.21-22
Otis; Otis/Cemco	22.23-25
Plunger Lift; Porta-flex	22.25
R & O	22.25-26
Richmond; San Jose	22.26
Schindler; Southeastern	22.27
Thyssenkrupp	22.28
United	22.29-30
U.S. Elevator	22.30-31
Westinghouse	22.32
White-Evans; Winter & Bain	22.33

Traction Machine Packing & Seals

Armor, Dover, Fujitec	22.34
Haughton; Hollister-Whitney; Montgomery	22.35
Otis; Park Manufacturing; F.S. Payne	22.36
U.S. Elevator	22.37
Watson, Westbrook/Southeastern, Westinghouse	22.37
Drip Rings	22.38
Packing Box Worksheet	22.39

Accessories

Packing Replacement Kit; Jack's Green Slime; Sanding Sleeve	22.40
Sure-Fit Repair Kit; Aligning System; O-Ring Splicing Kit	22.41
Cylinder Head ID Handbook	22.42

Manufacturers

not listed in Contents:

Kone, Montgomery-Kone:
See Montgomery
Kone in the U.S.: see Armor
Martin, D.L.: see Schindler
and Westinghouse
Reliable Elevator: see Amtech
Rotary Lift: see Dover
Schindler in Canada: see Armor
Thyssen: see U.S. Elevator

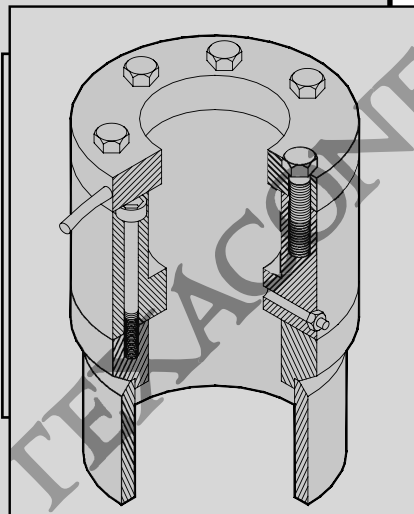
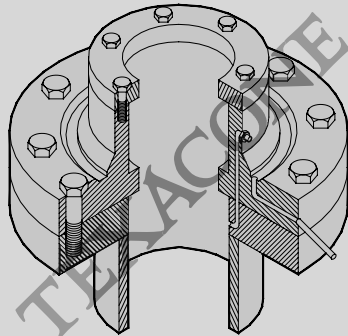

American Crescent

American Crescent—Commercial

Plunger Size	Solid Packing Set Number
3 1/2"	9EA109-06
4 1/2"	9EA109-07
5"	9EA109-08
5 1/2"	9EA109-09
6"	9EA109-10*
6 1/2"	9EA109-11*
7 1/2"	9EA109-14*
8 1/2"	9EA109-13*
12 1/2"	9EA109-12*

• Additional seal and lantern ring included.
Assembled as wiper, seal, lantern, seal, bearing.

American Crescent — Residential (Holeless)

Plunger Size	Solid Packing Set Number
2 1/2"	9EA109-01
2 7/8"	9EA109-02
3"	9EA109-05
3 1/8"	9EA109-03
3 1/2"	9EA109-06
3 7/8"	9EA109-04

Amtech (IDES A) Armor

Amtech (IDES A) (Mfd. since the 1970s)

Plunger Size	Solid Packing Set Number*	Split Packing Set Number	Split Autopak Set Number**
3"	6EA116-11	N/A	1AT114-11
3 7/8"	6EA116-06	6EA107-06	1AT114-09
4"	6EA116-01	6EA107-01	1AT114-10
4 3/8"	6EA116-07	6EA107-07	1AT114-01
4 1/2"	6EA116-02	6EA107-02	1AT114-02
5"	6EA116-03	6EA107-03	1AT114-03
5 7/16"	6EA116-08	6EA107-08	1AT114-04
5 1/2"	6EA116-04	6EA107-04	1AT114-05
6"	6EA116-09	6EA107-09	1AT114-06
6 1/2"	6EA116-05	6EA107-05	1AT114-07
7"	6EA116-10	6EA107-10	1AT114-08
8"	6EA116-12	N/A	1AT114-12

- *Split Packing is the recommended replacement.
- **Split 800 Packeting Set 6EA107-XX is available.
- Wiper: Units made after 2003 use snap-in wiper, older units use external wiper with clamps.

Armor

Plunger Size	Solid Packing Set Number
3"	9EA003-23
3 "	9EA003-24
4"	9EA003-26
4 1/4"	9EA003-17
4 7/16"	9EA003-01
4 1/2"	9EA003-25
5"	9EA003-18
5 1/2"	9EA003-02
6"	9EA003-19
6 9/16"	9EA003-03
7 9/16"	9EA003-04*
8 9/16"	9EA003-05
9 9/16"	9EA003-06
10 11/16"	9EA003-07
12 11/16"	9EA003-08

- *Lantern not available
- In Canada: "Schindler;" in USA: "Kone"
- Easily confused with Rosenberg or Long
- May require gasket (not included) if completely disassembled.

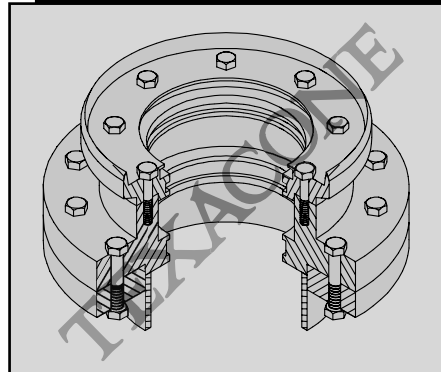
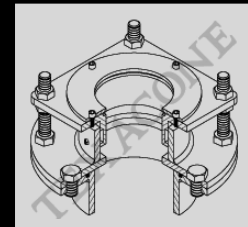
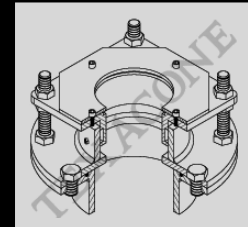
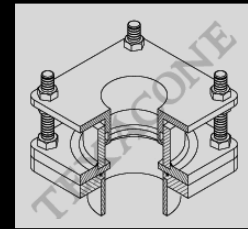
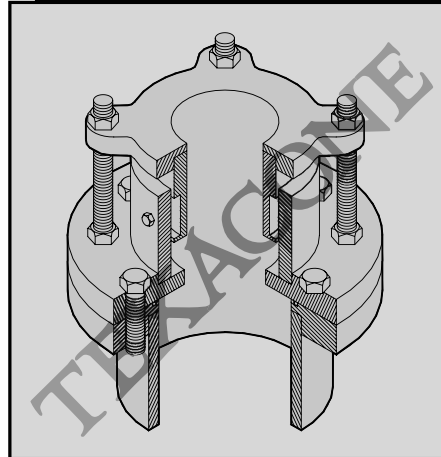

Illustrations are the property of Texacone and may not be reproduced without permission.

Questions? Answers at...
(866) CED-ELEV • (866) 233-3538
www.cedlevator.com

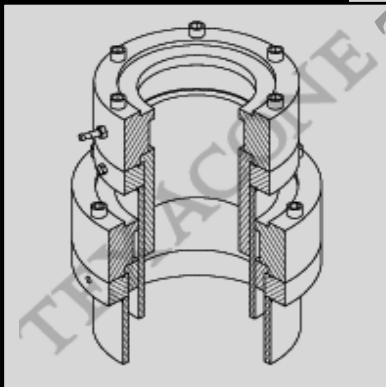
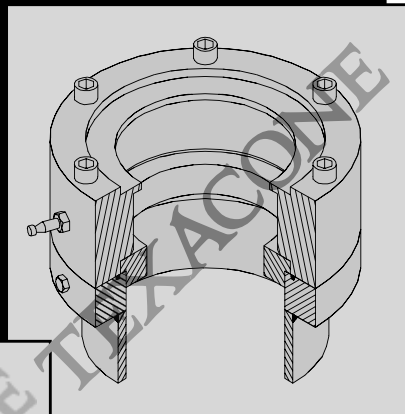
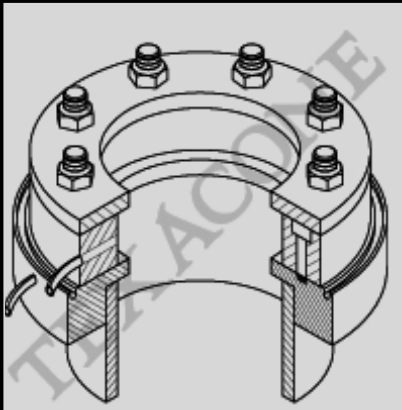
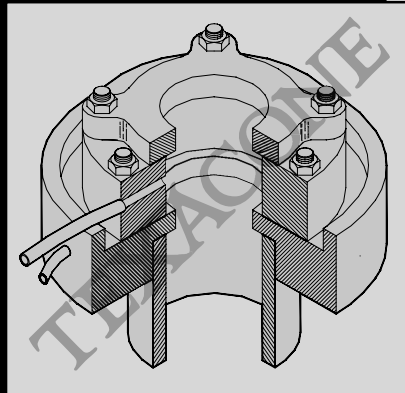

Bore-Max Canton

Bore-Max

Plunger Size	Solid Packing Set Number*	Seals Only Set Number (1 required)*	Split Autopak Set Number**
2½"	9EA006-01	9RF006-01	1AT083-01
3"	9EA006-19	9RF006-19	1AT083-19
3½"	9EA006-02	9RF006-02	1AT083-02
3¾"	9EA006-20	9RF006-20	1AT083-20
4"	9EA006-15	9RF006-15	1AT083-15
4¾"	9EA006-03	9RF006-03	1AT083-03
4½"	9EA006-21	9RF006-21	1AT083-21
5"	9EA006-04	9RF006-04	1AT083-04
5⅞"	9EA006-05	9RF006-05	1AT083-05
5½"	9EA006-06	9RF006-06	1AT083-06
6"	9EA006-14	9RF006-14	1AT083-14
6½"	9EA006-07	9RF006-07	1AT083-07
6⅞"	9EA006-08	9RF006-08	1AT083-08
7"	9EA006-09	9RF006-09	1AT083-09
7½"	9EA006-10	9RF006-10	1AT083-10
8"	9EA006-16	9RF006-16	1AT083-16
8½"	9EA006-11	9RF006-11	1AT083-11
9"	9EA006-17	9RF006-17	1AT083-17
9½"	9EA006-12	9RF006-12	1AT083-12
10"	9EA006-18	9RF006-18	1AT083-18
10½"	9EA006-22	9RF006-22	1AT083-22
10⅝"	9EA006-13	9RF006-13	1AT083-13

- Plunger > 6" normally has round cover plate.
- For Autopak Sets reuse the existing lantern, bearing and wiper. Autopak Sets come in 1-5-1 arrangement.
- 10" casings and above may require gasket or O-Ring if completely disassembled. Not available.

Canton (Mfrd. since the 1960's)

Plunger Size	Solid Packing Set Number	Telescopic
3"	9EA015-01	85/127mm 9EA160-01
3½"	9EA015-02	75/114/152mm 9EA160-02
4"	9EA015-03	
4½"	9EA015-04	
5"	9EA015-05	
5½"	9EA015-06	
6"	9EA015-07	
6½"	9EA015-08	
6⅞"	6EA015-09	
7"	9EA015-10	
7½"	9EA015-11	
8"	9EA015-12	
8½"	9EA015-13	
8⅞"	6EA015-14	
9"	9EA015-15	
9½"	9EA015-16	
10"	9EA015-17	
10½"	9EA015-18	

- Telescopic manufactured in Mid 1980's

Questions? Answers at...
(866) CED-ELEV • (866) 233-3538
www.cedlevator.com

Cemco—Flange (Screw on)

Plunger Size	Complete Packing Set Number
3 ⁷ / ₁₆ "	9EA019-11
3 ¹ / ₂ "	9EA019-01
3 ³ / ₄ "	9EA019-02
3 ⁷ / ₈ "	9EA019-24
4"	9EA019-03
4 ³ / ₈ "	9EA019-12
4 ⁷ / ₁₆ "	9EA019-13
4 ¹ / ₂ "	9EA019-04
5"	9EA019-05
5 ⁷ / ₁₆ "	9EA019-14**
5 ¹ / ₂ "	9EA019-06
6"	9EA019-07
6 ¹ / ₂ "	9EA019-08
7"	9EA019-09
7 ¹ / ₂ "	9EA019-15
8"	9EA019-16
8 ¹ / ₂ "	9EA019-10
9"	9EA019-17
9 ¹ / ₂ "	9EA019-18
10"***	9EA019-19
10 ¹ / ₂ "***	9EA019-20*
10 ⁵ / ₈ "	9EA019-21
12 ⁵ / ₈ "***	9EA019-23

- Often confused with EECO LJ.
- *No wiper available.
- **These are not common.

Cemco—Welded Single Seal

Plunger Size	Complete Packing Set Number
2 ¹ / ₂ "	9EA106-14
2 ³ / ₄ (70mm)	9EA106-08
3 ⁷ / ₁₆ "	9EA106-01
3.93 (100mm)	9EA106-02*
4 ¹ / ₂ "	9EA106-03*
5"	9EA106-04
5 ¹ / ₂ "	9EA106-05
6"	9EA106-09
6 ¹ / ₂ "	9EA106-06
7"	9EA106-10
7 ¹ / ₂ "	9EA106-11
8"	9EA106-12
8 ¹ / ₂ "	9EA106-11

- Contains additional O-Ring
- *3.93 and 5¹/₂" can be easily confused with the Otis/Cemco head packaging.

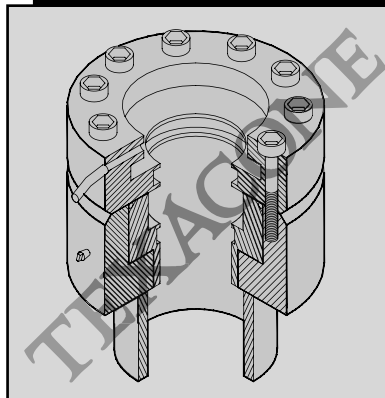
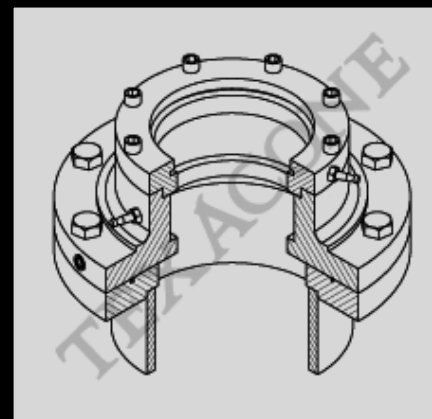
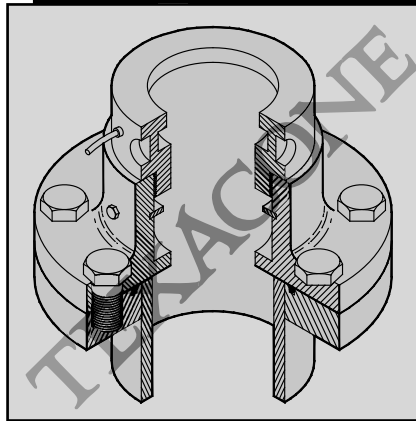

Illustrations are the property of Texacone and may not be reproduced without permission.

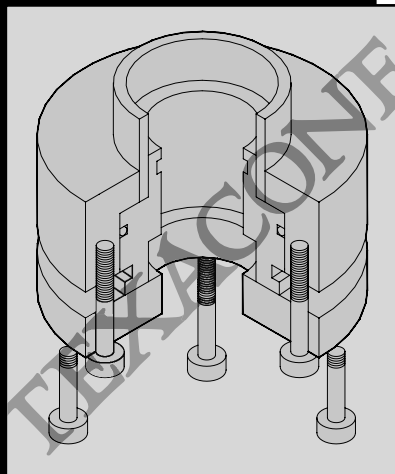
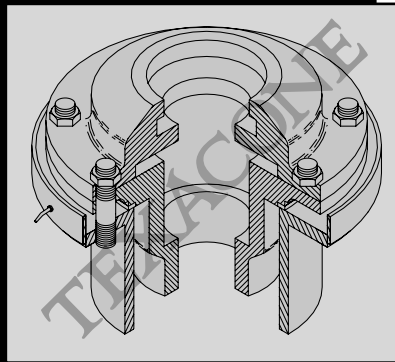
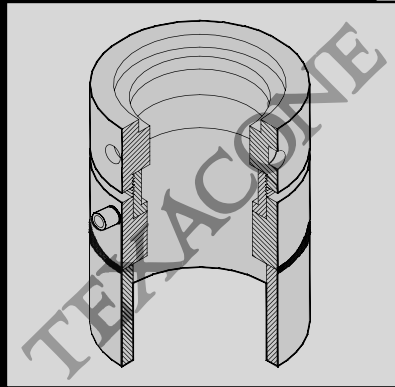

Coast Concord Dover (Thyssenkrupp)

Coast (CA)

Plunger Size	Solid Packing Set Number
4"	6EA035-01
4 ³ / ₈ "	6EA035-02
5"	6EA035-03
5 ⁷ / ₁₆ "	6EA035-04
5 ¹ / ₂ "	6EA035-05
6"	6EA035-06
6 ⁷ / ₁₆ "	6EA035-07
6 ¹ / ₂ "	6EA035-08
7"	6EA035-09
7 ¹ / ₂ "	6EA035-10
8"	6EA035-11
8 ¹ / ₂ "	6EA035-12
10"	6EA035-13

• Recommend O-Ring Splicing Kit - 1RA027

Concord

Plunger Size	Solid Packing Set Number
1 ¹ / ₂ "	9EA152-01
2"	9EA152-02
2 ¹ / ₂ "	9EA152-03
2 ³ / ₄ "	6EA152-04
3 ¹ / ₄ "	6EA152-05

• Place the (2) wear rings together in the groove

Dover (Thyssenkrupp)—IVO

Plunger Size	Split Autopak Set Number
3 ⁷ / ₈ "	1A084-10*

- * Autopak is the recommended replacement packing.
- Inverted cylinder. Unit extremely difficult to disassemble to install solid seals. Specify if solid set is preferred.

Dover (Thyssenkrupp)

Dover (Thyssenkrupp)—Rota

Plunger Size	Solid Packing Set Number
3 1/2" (3S)	3EA023-11*
4 3/8" (4S)	9EA023-12
5 7/16" (5S)	9EA023-13
6 1/2" (6S)	9EA023-14
7 1/2" (7S)	4E104**

Older Two-Seal Units

Use Solid Set plus Steel Spacer

4 3/8" (4S)	9EA023-12	1S212
5 7/16" (5S)	9EA023-13	1S213
6 1/2" (6S)	9EA023-14	1S214

- ** 7-1/2" Seal only Available!
- * 2 Seal Units require spacer. Use Packet Set and Spacer - Do Not Use 2 Seals in tandem.
- Do not use standard 1/2 cross section seal below ROTA seal as this may result in excessive friction.
- ** O-Ring not available.
- Either use gasket or O-ring, never both.

Dover (Thyssenkrupp)—Rotary

Plunger Size	Solid Packing Set Number	Autopak Set Number*
AFTER 2006		
7-1/2" (7S)	3EA023-04	
8-1/2" (8S)	3EA023-05	
9-1/2" (9S)	3EA023-06	
10-5/8" (10S)	3EA023-07	
12-5/8" (12S)	3EA023-08	
15-3/4" (15S)	3EA023-09*	
BEFORE 1955 AND 1965-1968		
4-3/8"		1AT084-01
5-7/16"		1AT084-02
6-1/2"		1AT084-03
BEFORE 2006		
7-1/2" (7S)		1AT084-04
8-1/2" (8S)		1AT084-05
9-1/2" (9S)		1AT084-06
10-5/8" (10S)		1AT084-07
12-5/8" (12S)		1AT084-08
15-3/4" (15S)		1AT084-09*

- * Wiper not available
- Older units are babbitted bearing. Newer units use split plastic wear ring which is available upon request
- After 2006, packing box is shorter and requires 1 seal
- 4-3/8, 5-7/16, And 6-1/2 packing sets and seals are for rotary manufactured prior to 1955 and between 1965-1968. other than those years, see DOVER-ROTA

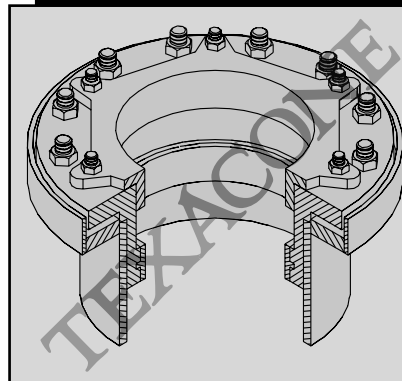
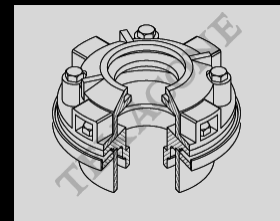
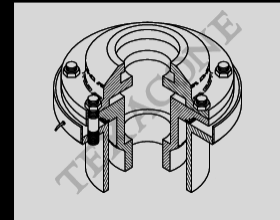
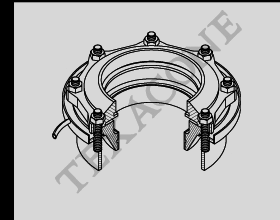
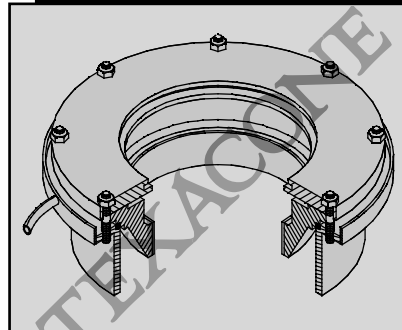

Illustrations are the property of Texacone and may not be reproduced without permission.

Questions? Answers at...
(866) CED-ELEV • (866) 233-3538
www.cedlevator.com

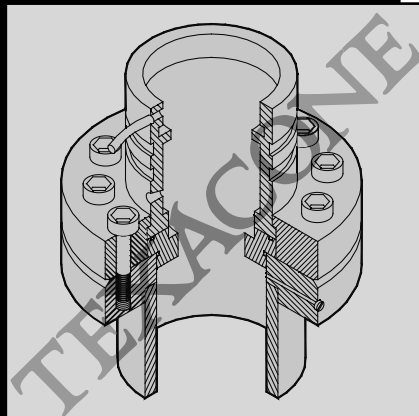
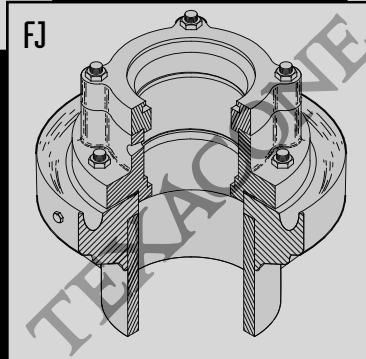
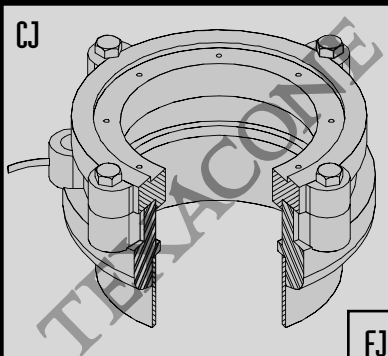

EECO

EECO—CJ* & FJ

Plunger Size	Solid Packing Set Number**	Autopak Set Number
2 ³ / ₄ "	9EA008-18*	1AT089-13
3 ⁷ / ₁₆ "	9EA008-10	1AT089-10
3 ¹ / ₂ "	9EA008-19	1AT089-14
3 ⁷ / ₈ "	9EA008-11	1AT089-11
4"	9EA008-12	1AT089-12
4 ³ / ₈ "	9EA008-01	1AT089-01
5"	9EA008-02	1AT089-02
5 ⁷ / ₁₆ "	9EA008-03	1AT089-03
6"	9EA008-04	1AT089-04
6 ¹ / ₂ "	9EA008-05	1AT089-05
7 ¹ / ₂ "	9EA008-06	1AT089-06
8 ¹ / ₂ "	9EA008-07	1AT089-07
9 ¹ / ₂ "	9EA008-20	
10 ⁵ / ₈ "	9EA008-08*	1AT089-08
12 ⁵ / ₈ "	9EA008-09*	1AT089-09

- * NOTE: CJ units were manufactured before 1965 and do NOT resemble the FJ head. Recommend Autopak.
- "FJ" is cast into head by bleeder valve which is positioned at 45° angle.
- * Bearing used in set instead of shoulder bearing

EECO—HJ

Plunger Size	Solid Packing Set Number*
4 ³ / ₈ "	6EA008-13
5"	6EA008-14
5 ⁷ / ₁₆ "	6EA008-15
6"	6EA008-16
6 ¹ / ₂ "	6EA008-17

- EECO recommends calling for replacement cylinder head.
- Very few exist. Looks identical to LJ on outside.

EECO—LJ

Plunger Size	Solid Packing Set Number
2 ³ / ₄ "	9EA008-18*
3 ⁷ / ₁₆ "	9EA008-10
3 ¹ / ₂ "	9EA008-19
3 ⁷ / ₈ "	9EA008-11
4"	9EA008-12
4 ³ / ₈ "	9EA008-01
5"	9EA008-02
5 ⁷ / ₁₆ "	9EA008-03
6"	9EA008-04
6 ¹ / ₂ "	9EA008-05
7 ¹ / ₂ "	9EA008-06
8 ¹ / ₂ "	9EA008-07
9 ¹ / ₂ "	9EA008-20
10 ⁵ / ₈ "	9EA008-08*
12 ⁵ / ₈ "	9EA008-09*

TLJ—Telescopic**

3 ¹ / ₂ " / 5 ⁷ / ₁₆ "	9EA008-22
4 ³ / ₈ " / 6 ¹ / ₂ "	6EA008-23

- *Bearing used in set instead of shoulder bearing.
- ** Telescopic units require (2) sets plus piston seal.
- HJ uses a different top seal, call for availability

EECO—NJ, PJ & TJ

Plunger Size	Solid Packing Set Number*
2 ³ / ₄ "	9EA120-01
3"	9EA120-02
3 ⁷ / ₁₆ "	9EA120-03
3 ⁷ / ₈ "	9EA120-04
4"	9EA120-05
4 ³ / ₈ "	9EA120-06
5"	9EA120-07
5 ⁷ / ₁₆ "	9EA120-08
6"	9EA120-09
6 ¹ / ₂ "	9EA120-10
7"	9EA120-14
7 ¹ / ₂ "	9EA120-15
8"	9EA120-19
8 ¹ / ₂ "	9EA120-13

- NJ manufactured from 1989 to 1996.
- PJ manufactured after 1996
- 2³/₄" & 3⁷/₁₆" easily confused with custom Elev. Mfg.
- Most sets include O-Rings for both NJ and PJ units, discard extra
- Smaller sizes contain rod seal as standard

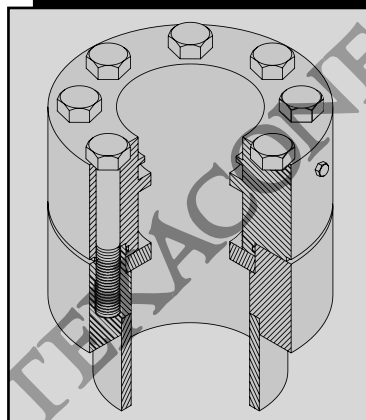
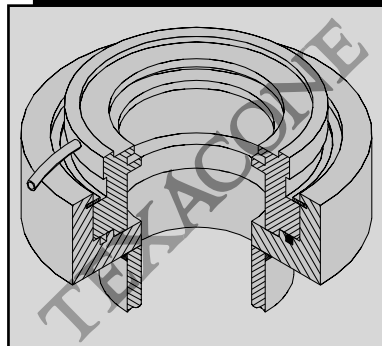
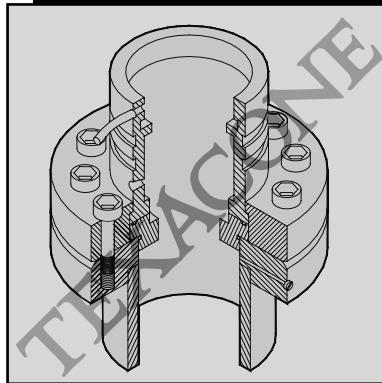

Illustrations are the property of Texacone and may not be reproduced without permission.

Questions? Answers at...
 (866) CED-ELEV • (866) 233-3538
www.cedelevator.com

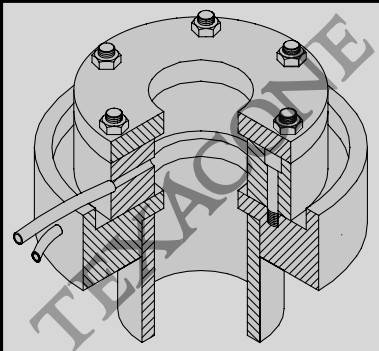
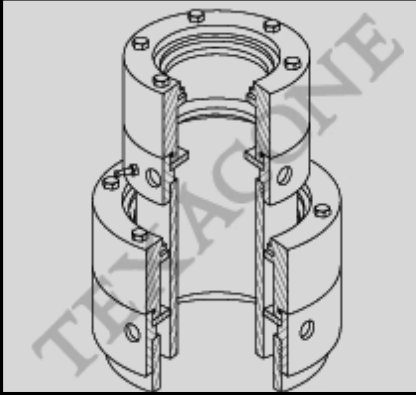

EECO and Elevator Manufacturing

EECO—PJ & TJ

TJ—Telescopic*

Plunger Size	Solid Packing Set Number
2½"	9EA120-16
2¾"	9EA120-11
4"	9EA120-17
4½"	9EA120-18**

- *Complete TJ set includes (3) bearings and (3) seals and (2) O-Rings. For replacement seals only, order the (3) seals listed.
- ** Call for availability.
- PJ manufactured after 1996.
- 2¾" & 3⅞" may be confused with custom Elev. Mfg. (see opposite page)

Elevator Manufacturing

Plunger Size	Solid Packing Set Number
3"	9EA137-19
3½"	9EA137-02
4"	9EA137-15
4¾"	9EA137-03
5"	9EA137-04
5⅞"	9EA137-05
5½"	9EA137-06
6"	9EA137-14
6½"	9EA137-07
7"	9EA137-09
8½"	9EA137-11
10½"	9EA137-22
10⅝"	9EA137-13

- May require gasket (not included) if completely disassembled.
- Plunger > 6" normally has round cover plate.

Esco—P3 & P7

Plunger Size	Solid Packing Set Number*
2½"	9EA024-01
3"	9EA024-02
4"	9EA024-03
4½"	9EA024-04
5"	9EA024-05
5½"	9EA024-06
6"	9EA024-07
6½"	9EA024-35
7"	9EA024-08
7½"	9EA024-36
8"	9EA024-09
9"	9EA024-10
10 ⁵ / ₈ "	9EA024-11
12 ⁵ / ₈ "	9EA024-12
13 ⁷ / ₈ "	3EA024-32*
15 ⁷ / ₈ "	3EA024-33*
17 ⁷ / ₈ "	3EA024-34*

- * Wiper not available.
- May require gasket (not included) if completely disassembled.

Esco—P4 Line Seal

Plunger Size	Solid Packing Set Number
4"	9EA024-13
4½"	9EA024-14
5"	9EA024-15
5½"	9EA024-16
6"	9EA024-17
7"	9EA024-18
8"	9EA024-19
9"	9EA024-20
10 ⁵ / ₈ "	3EA024-21

- The conventional seal replaces the line seals used between 1966 and 1972. To install the conventional seal simply flip the top flange over so that the machined groove is facing upward.
- May require gasket (not included) if completely disassembled.

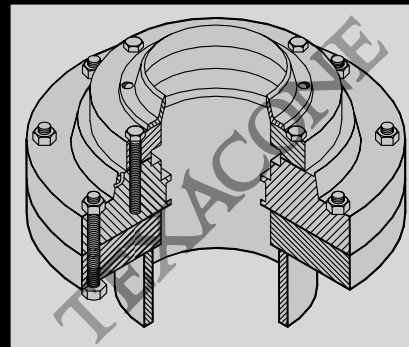
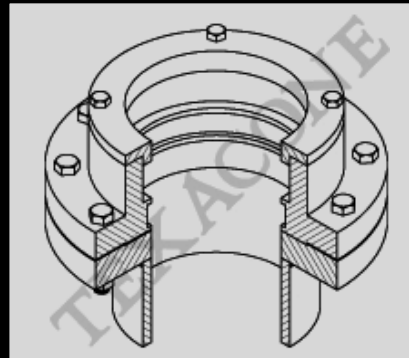
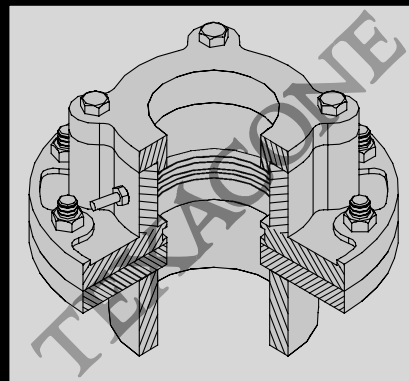

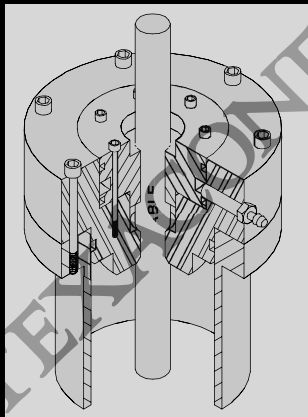
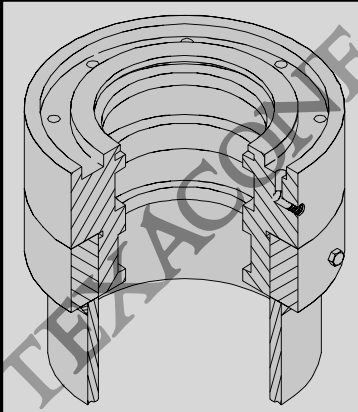
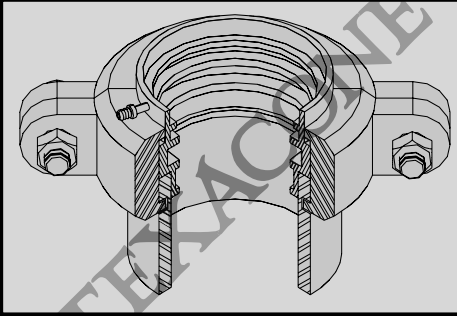

Esco

Esco—P6 Victaulic

Plunger Size	Solid Packing Set Number
4"	9EA024-22*
4½"	9EA024-23
5"	9EA024-24
5½"	9EA024-25
6"	9EA024-26
6½"***	9EA024-30
7"	9EA024-27
7½"	9EA024-36
8"	9EA024-09

Victaulic Gasket

Gasket Size	Part Number
4" thru 4½"	1G022-6*
5" thru 6½"	1G021-8*
6½" thru 8"	1G023-10*

- * O-Ring included. Required for holeless units only.
- 6½" plunger requires either the 8" or 10" Victaulic gasket. Must measure.
- For plungers larger than 7" the Victaulic head requires the same configuration as P3 & P7 head.

Esco—P9 Holeless—886

Plunger Size	Solid Packing Set Number
¾" (Before July 1983)	3EA024-28
¾" (After July 1983)	3EA024-29
¾" (Both Seals)	3EA024-37*
4"	9EA024-22

- If date is not known, recommend 3EA024-37 which contains seals for both ¾" versions.

Esco—Cable Roped

Cable Size	Solid Packing Set Number*
⅝"	6EA129-01
⅝" (RES)	6EA129-02
⅝"	6EA129-03*
¾"***	7E025

- * Not as common. Only way to determine correct packing is to disassemble call for assistance. Split wear rings used instead of solid bearings shown.
- ** Call for Complete set availability.
- Each unit requires (4) sets except ⅝" RES which requires (2) sets.

Questions? Answers at...
 (866) CED-ELEV • (866) 233-3538
www.cedlevator.com

Federal Florlift GCE

Federal

Plunger Size	Solid Packing Set Number
2 ³ / ₈ "	6EA140-01
2 ³ / ₄ "	9EA140-02
3 ¹ / ₂ "	9EA140-03

- This is a direct replacement for the original factory supplied "chevron" style.
- Identical look new head design in 2004 uses smaller O-Ring.

Florlift

Plunger Size	Solid Packing Set Number
2"	6EA144-01
2 ¹ / ₂ "	6EA144-02
3"	6EA144-03
4"	6EA144-04

- Looks similar to Giant Lift
- "Old" Florlift heads use different seal. Call for availability.

GCE

Plunger Size	Solid Packing Set Number	Replacement Seal Number (1 required)
2 ⁷ / ₈ "	9EA148-01*	9E035
3"	9EA1148-02	9E051

- * O-Ring included.
- Heads used with multi-piece plungers require O-Ring.

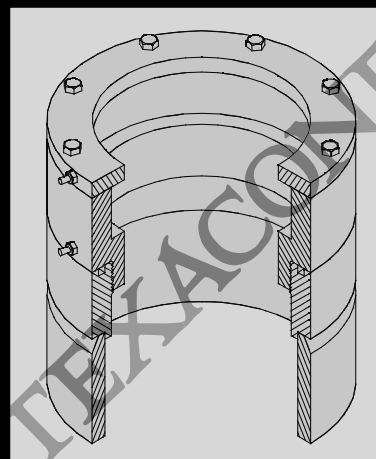
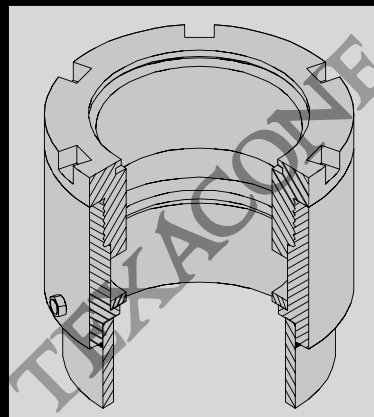
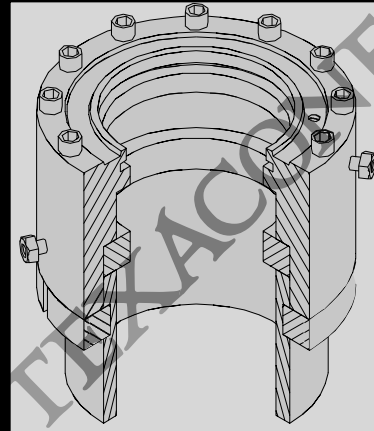

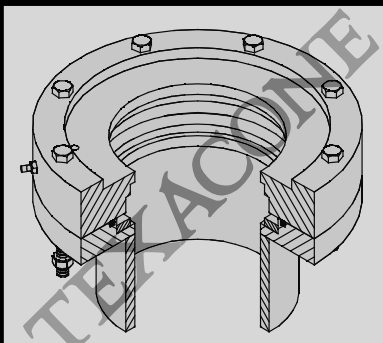
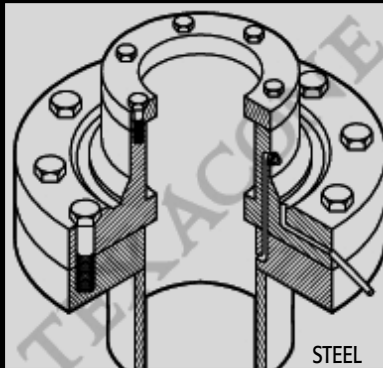
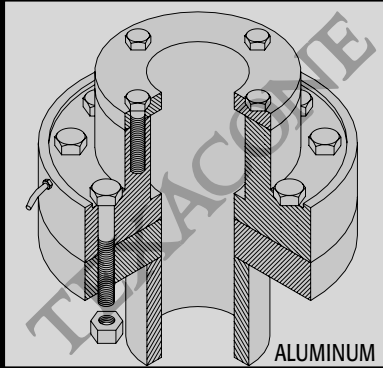

General

General Steel & Aluminum

Plunger Size	Solid Packing Set Number	
	Steel	Aluminum
3 ⁷ / ₁₆ "	9EA014-12	9EA159-01
3 ¹ / ₂ "	9EA014-01	9EA159-02
3 ¹⁵ / ₁₆ "	6EA014-11	9EA159-03
4"	9EA014-13	9EA159-04
4 ⁷ / ₁₆ "	9EA014-02	9EA159-05
4 ¹ / ₂ "	9EA014-10	9EA159-06
5"	9EA014-14	9EA159-07
5 ⁷ / ₁₆ "	9EA014-03	9EA159-08
5 ¹ / ₂ "	9EA014-15	9EA159-09
6 ⁷ / ₁₆ "	6EA014-04	9EA159-10
6 ¹ / ₂ "	9EA014-05	9EA159-11
7 ¹ / ₂ "	9EA014-06	9EA159-12
8 ¹ / ₂ "	9EA014-07	9EA159-13
9 ¹ / ₂ "	9EA014-08	9EA159-14

- Additional sizes available, please inquire.
- May require gasket (not included) if completely disassembled.

General — F2

Plunger Size	Solid Packing Set Number
4 ⁷ / ₁₆ "	9EA151-01
4 ¹ / ₂ "	9EA151-02
5 ¹ / ₂ "	9EA151-03
5 ¹⁷ / ₃₂ "	9EA151-04
6 ¹ / ₂ "	9EA151-05
6 ¹⁷ / ₃₂ "	9EA151-06
7 ¹ / ₂ "	9EA151-07
7 ¹⁷ / ₃₂ "	9EA151-08
8 ¹ / ₂ "	9EA151-09
8 ¹⁷ / ₃₂ "	9EA151-10

- Additional sizes available, please inquire.
- O-Ring sizes vary per unit. See O-Ring Splicing Kit page.
- Reuse existing shoulder bearing. Replacements available upon request.

Global Globe Hoist Hollister-Whitney

Global (Hydrotech Cylinders)

Plunger Size	Solid Packing Set Number
2"	9EA121-01
2½"	9EA121-02
2¾"	9EA121-03
3"	9EA121-04
3½"	9EA121-05
4"	9EA121-06
4¾"	9EA121-16
4½"	9EA121-07
5"	9EA121-08
5⅞"	9EA121-15
5½"	9EA121-09
6"	9EA121-10
6½"	9EA121-11
7½"	9EA121-12*
8½"	6EA121-13*
10⅝"	9EA121-14*

- *These sets contain (2) seals. Assembled as wiper, seal, bearing, seal.
- Manufactured until 2006.

Globe Hoist

Plunger Size	Split Autopak Set Number
4¾"	1AT117-01
5¾"	1AT117-02
6⅞"	1AT117-03
7½"	1AT117-04
8½"	1AT117-05
10⅝"	1AT117-06

Hollister-Whitney (Old)

Plunger Size	Complete Packing Set Number
4¾"	9EA119-01
4½"	9EA119-02
5¾"	9EA119-03
5⅞"	9EA119-04
6½"	9EA119-05
7½"	9EA119-06
8½"	9EA119-07
10⅝"	9EA119-08

- Manufactured from 1970 to 1981

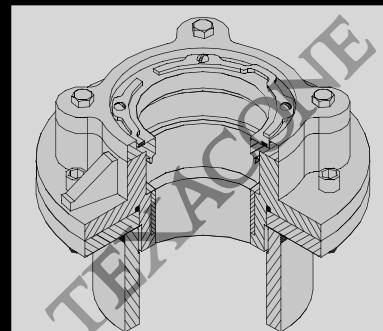
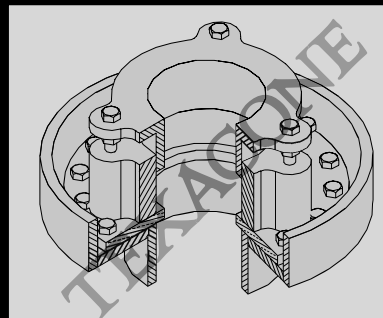
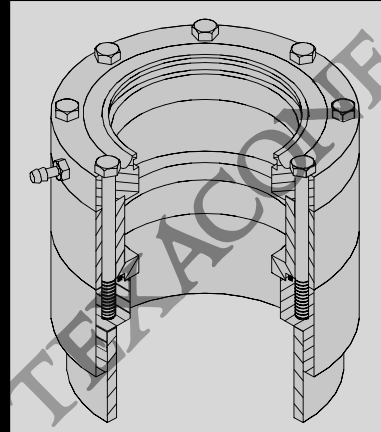

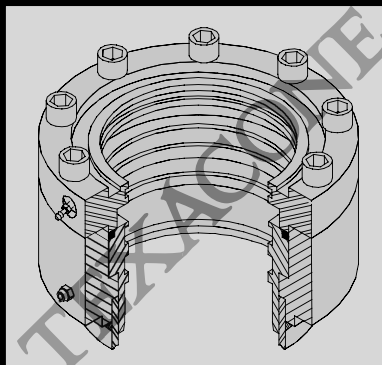
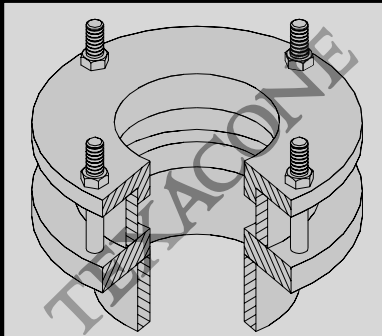
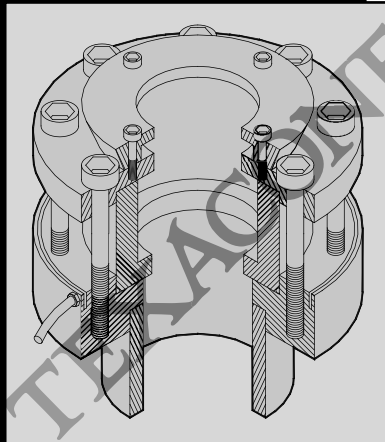
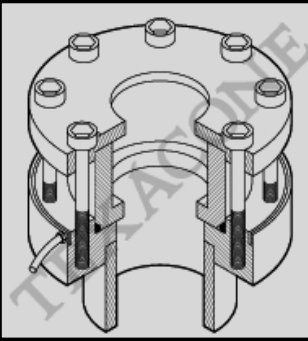

Hollister-Whitney Home Hydromoris Inclinator

Hollister-Whitney

Plunger Size	Solid Packing Set Number
4 ³ / ₈ "	9EA017-01
4 ¹ / ₂ "	9EA017-02
5 ³ / ₈ "	9EA017-03
5 ⁷ / ₁₆ "	9EA017-04
6 ¹ / ₂ "	9EA017-05
7 ¹ / ₂ "	9EA017-06
8 ¹ / ₂ "	9EA017-07
10 ⁵ / ₈ "	9EA017-08

Home

Plunger Size	Split Autopak Set Number
4"	1A107-01
4 ¹ / ₂ "	1A107-02
5"	1A107-03
5 ¹ / ₂ "	1A107-04
6"	1A107-05

• Not supplied as Super Slick Autopak.

Hydromoris (Hone)

Plunger Size	Solid Packing Set Number
60mm	9EA131-01
70mm	9EA131-02
80mm	6EA131-03
90mm	9EA131-04
100mm	9EA131-05
110mm	9EA131-06
120mm	9EA131-07
130mm	9EA131-08
140mm	9EA131-09
150mm	9EA131-10
160mm	9EA131-11
180mm	9EA131-12
200mm	9EA131-13

• Manufactured from 2000 to 2004.

• Easily confused with Oil Lift (OLS/GMV)

Inclinor ITI

Inclinor

Plunger Size	Solid Packing Set Number
2 ⁵ / ₁₆ "	9EA135-01
2 ¹³ / ₁₆ "	9EA135-02

ITI—In Ground

Plunger Size	Cross Section	Solid Packing Set Number	Plunger Size	Packing Set Number
3 ¹ / ₂ "	1/2	9EA138-09	3 ¹ / ₂ "	9EA169-09
4"	1/2	9EA138-13	4"	9EA169-13
4 ³ / ₈ "	1/2	9EA138-15	4 ³ / ₈ "	9EA169-14
4 ⁷ / ₁₆ "	1/2	9EA138-17	4 ⁷ / ₁₆ "	9EA169-15
4 ¹ / ₂ "	1/2	9EA138-14	4 ¹ / ₂ "	9EA169-16
4 ⁵ / ₈ "	1/2	9EA138-16	4 ⁵ / ₈ "	9EA169-17
5"	1/2	9EA138-18	4 ¹⁵ / ₁₆ "	9EA169-31
5 ⁷ / ₁₆ "	1/2	9EA138-20	5"	9EA169-18
5 ¹ / ₂ "	1/2	9EA138-19	5 ⁷ / ₁₆ "	9EA169-19
6"	1/2	9EA138-21	5 ¹ / ₂ "	9EA169-20
6 ¹ / ₂ "	1/2	9EA138-22	6"	9EA169-21
6 ⁹ / ₁₆ "	1/2	9EA138-23	6 ¹ / ₂ "	9EA169-22
7 ¹ / ₂ "	1/2	9EA138-24	6 ⁹ / ₁₆ "	9EA169-23
8"	1/2	9EA138-25	7 ¹ / ₂ "	9EA169-24
8 ⁹ / ₁₆ "	1/2	9EA138-26	8"	9EA169-25
9 ¹ / ₂ "	1/2	9EA138-27	8 ⁹ / ₁₆ "	9EA169-26
9 ⁹ / ₁₆ "	1/2	9EA138-28	9"	9EA169-32
10 ¹¹ / ₁₆ "	1/2	6EA138-29	9 ¹ / ₂ "	9EA169-27
12 ¹¹ / ₁₆ "	1/2	6EA138-30	9 ⁹ / ₁₆ "	9EA169-289
			10 ⁵ / ₈ "	9EA169-33
			10 ¹¹ / ₁₆ "	9EA169-29
			12 ¹¹ / ₁₆ "	9EA169-30

- Manufactured before 2005
- Easily confused with ITI Hydraulik Pop-In
- Other sizes available, call with plunger size and cross section
- O-Ring sizes vary per unit. See O-Ring Splicing Kit (page 24.43).
- First digit of serial number indicates type of unit:
(2) in ground, (3) holeless, (4) telescopic.
- * Pop-in vs two seal heads: Pop-in has 2 ports and is shorter.
Two seal has 3 ports and is taller.

Illustrations are the property of Texacone and may not be reproduced without permission.

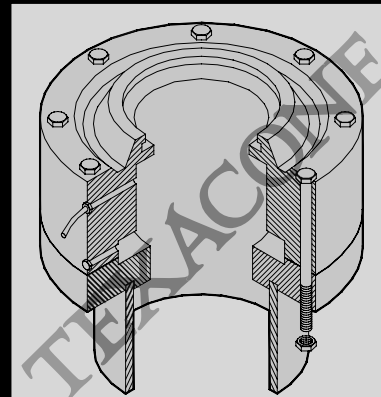
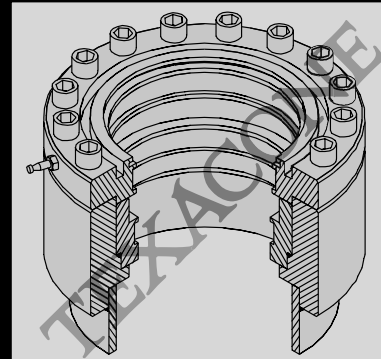

Questions? Answers at...
(866) CED-ELEV • (866) 233-3538
www.cedelevator.com

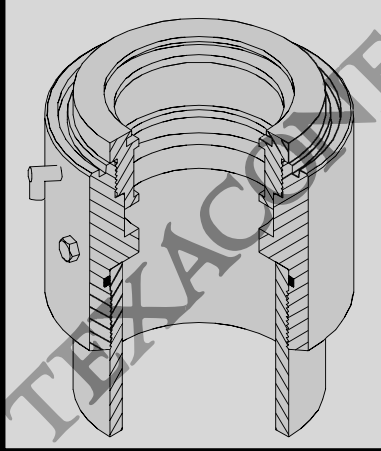

ITI Lift-Avator

ITI—Holeless & Telescopic

Plunger Size	Cross Section	Solid Packing Set Number
1 3/4"	3/8"	6EA146-01
2"	3/8"	6EA146-03
2 1/2"	3/8"	6EA146-04
2 3/4"	3/8"	6EA146-05
3"	3/8"	6EA146-06
3 1/2"	1/2"	6EA146-08
3 1/2"	3/8"	6EA146-09
3 3/4"	1/2"	9EA146-10
3 7/8"	1/2"	9EA146-10
4"	3/8"	9EA146-12
4"	1/2"	9EA146-13
4 3/8"	1/2"	9EA146-15
4 7/16"	1/2"	9EA146-17
4 1/2"	1/2"	9EA146-14
4 5/8"	1/2"	9EA146-16
4 7/8"	1/2"	6EA146-31
5"	1/2"	9EA146-18
5 7/16"	1/2"	9EA146-20
5 1/2"	1/2"	9EA146-19
6"	1/2"	9EA146-21
6 1/2"	1/2"	9EA146-22
6 9/16"	1/2"	9EA146-23
7 1/2"	1/2"	9EA146-24
8"	1/2"	9EA146-25
8 9/16"	1/2"	9EA146-26
9 1/2"	1/2"	9EA146-27
9 9/16"	1/2"	9EA146-28
10 11/16"	1/2"	6EA146-29
12 11/16"	1/2"	6EA146-30

- Complete seal repack for telescopic units require (2) or more sets plus piston seal.
- Other sizes available, call with plunger size and cross section
- Most sets contain several O-Rings to accommodate different cylinder sizes
- First digit of serial number indicates type of unit: (2) in ground, (3) holeless, (4) telescopic.
- Uses bronze screw on head.

Marmac Montgomery (Kone)

Marmac

Plunger Size	Split Autopak Set Number
4 ³ / ₈ "	1A119-01
5 ³ / ₈ "	1A119-02
6 ¹ / ₂ "	1A119-03
8 ¹ / ₂ "	1A119-04
10 ¹ / ₂ "	1A119-05
12 ¹ / ₂ "	1A119-06
13 ³ / ₄ "	1A119-07
15 ³ / ₄ "	1A119-08
17 ³ / ₄ "	1A119-09
18 ³ / ₄ "	1A119-10
21 ³ / ₄ "	1A119-11

- Autopak not supplied as superslick
- Some units use an "Oil Reclaimer" Lantern. If so equipped, must reuse lantern. May have extra rings left over after repack.
- 10 1/2" plungers and larger uses non-standard wiper. Not available at this time

Montgomery (Kone)— Cast & Machined

Plunger Size	Split Autopak Set Number*
3 ¹⁵ / ₁₆ "	1AT074-37
4 ³ / ₈ "	1AT074-47
4.46"	1AT074-38
5 ⁷ / ₁₆ "	1AT074-48
5.52"	1AT074-39
5.72"	1AT074-40
6 ¹ / ₂ "	1AT074-49
6.59"	1AT074-41
7.47"	1AT074-42
8 ¹ / ₂ "	1AT074-50
8.57"	1AT074-43
9.47"	1AT074-44
10.7"	1AT074-45*
12.7"	1AT074-46*

- * Autopak is not supplied as superslick. Must use spacer or filler ring with Autopak sets to compress packing.
- Uses bronze gland.
- May require gasket if completely disassembled. Not available.
- Plungers 8.57 and larger, also see Montgomery (Kone) 1993

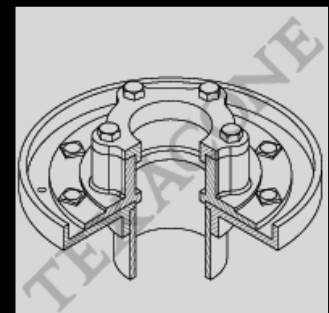
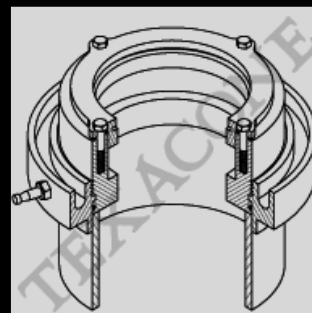
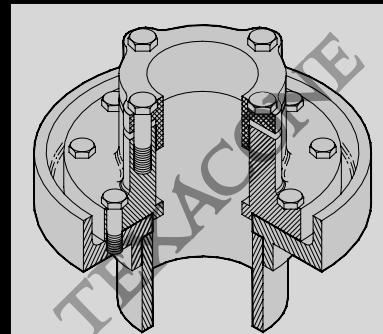
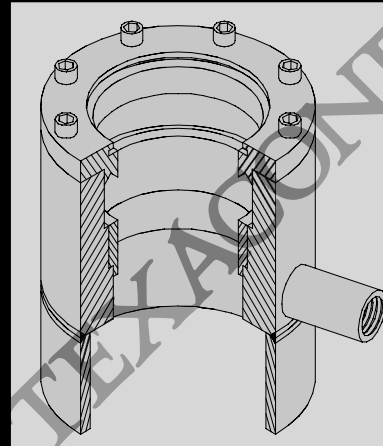

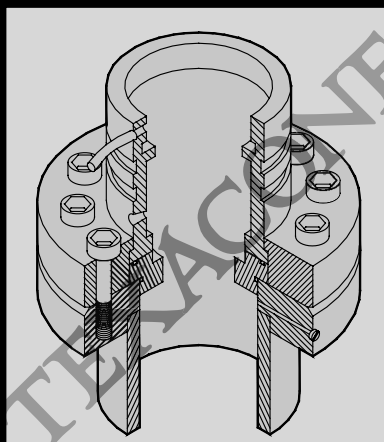
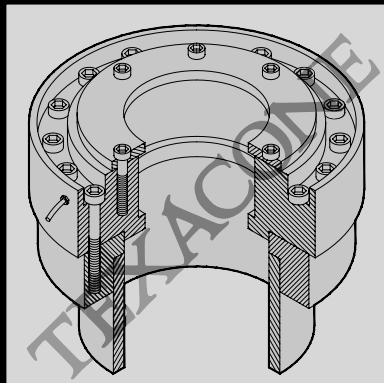
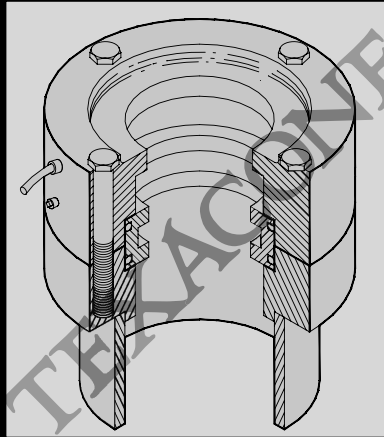

Montgomery (Kone) & Mowrey

Montgomery (Kone)—Holeless

Plunger Size	Solid Packing Set Number
2.84"	9EA018-03
3"	9EA018-01
3½"	9EA018-02

- Some older units do not have groove for wear ring.
- Usually need (2) sets per car.
- Metal ring in bottom of head **MUST** be removed to replace seals

Montgomery (Kone)—1993

Plunger Size	Solid Packing Set Number
8.57"	3EA026-25
9.47"	3EA026-24
10.7"	3EA026-21
12.7"	3EA026-22

- Manufactured from 1993

Mowrey

Plunger Size	Solid Packing Set Number
3⅞"	9EA063-09
4"	9EA063-10
4⅜" (4m)	9EA063-01
4½"	9EA063-11
5"	9EA063-12
5⅞" (5m)	9EA063-02
5½"	9EA063-13
6"	9EA063-14
6½" (6m)	9EA063-03
7½"	9EA063-14

- Usually does not have grooves on barrel.
- Often confused with Cemco Flanges.

Northern Oil Lift Systems

Northern QPH

Plunger Size	Cross Section	Solid Packing Set Number
2 1/2"	3/8"	9EA095-10*
3"	3/8"	9EA095-01
3 1/2"	3/8"	9EA095-02
3 1/2"	1/2"	9EA095-05
4"	3/8"	9EA095-03
4"	1/2"	9EA095-06
4 1/2"	3/8"	9EA095-04
4 1/2"	1/2"	9EA095-07
4.96"	3/8"	9EA095-11
5"	3/8"	9EA095-08
5 1/2"	1/2"	9EA095-12
6"	1/2"	9EA095-13
6.48"	1/2"	9EA095-17
6 1/2"	1/2"	9EA095-14
7"	1/2"	9EA095-15
7 1/2"	1/2"	9EA095-16
8 1/2"	1/2"	9EA095-09

- * No O-Ring available. Recommend O-Ring splicing kit. Any head tagged as Northern after 1995 install date is probably a Thyssenkrupp unit, usually a Roped Hydro.

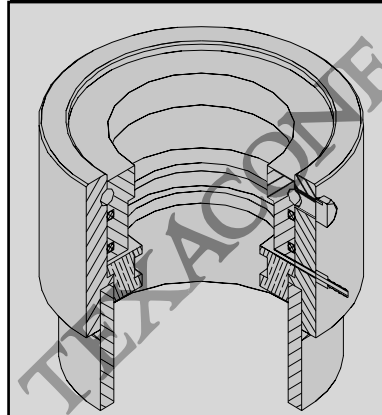

Oil Lift Systems (OLS, GMV) Single Stage

Plunger Size	Solid Packing Set Number*
42mm	9EA133-14
50mm	9EA133-08
60mm	9EA133-07
70mm	9EA133-01
80mm	9EA133-02
90mm	9EA133-03
100mm	9EA133-04
110mm	9EA133-05
120mm	9EA133-06
130mm	9EA133-09
140mm	9EA133-18
150mm	9EA133-10
180mm	9EA133-11*
200mm	9EA133-12**
238mm	9EA133-13**

- * Wiper not available on some sets.
- ** Call for availability.
- Some sets contain several O-Rings for single stage or "S" telescopic
- Easily confused with Hydromoris and Inclinator, MUST measure accurately.

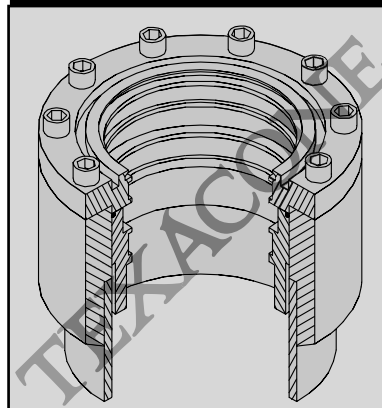

Illustrations are the property of Texacone and may not be reproduced without permission.

Questions? Answers at...
 (866) CED-ELEV • (866) 233-3538
www.cedlevator.com

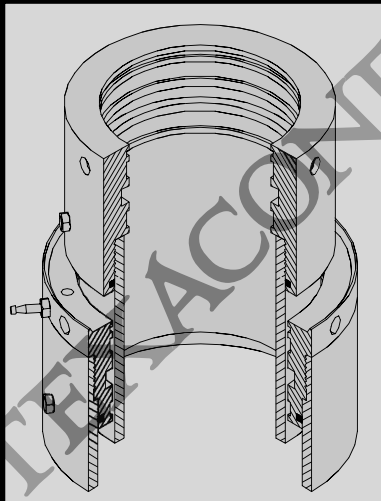
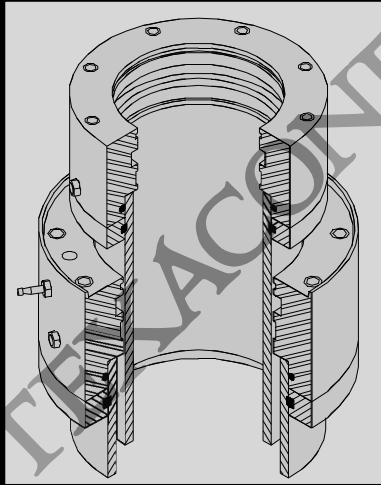
SCREW ON

Oil Lift Systems

Oil Lift Systems "H" Top Bolt Telescopic

Plunger Size	Solid Packing Set Number*
42mm	9EA141-01*
50mm	9EA141-02*
56mm	9EA141-03*
63mm	9EA141-04*
70mm	9EA141-05*
85mm	9EA141-06*
100mm	9EA141-07*
120mm	9EA141-08*
140mm	9EA141-09*
170mm	9EA141-10*
200mm	9EA141-11*

- * Call for availability of complete set.
- Easily confused with Hyda
- Wiper not available. Some units may require (2) wear rings.

Oil Lift Systems [OLS, GMV] "S" Telescopic

Plunger Size	Solid Packing Set Number*
42mm	9EA133-14
50mm	9EA133-08
56mm	9EA133-15
63mm	9EA133-16
70mm	9EA133-01
85mm	9EA133-17
100mm	9EA133-04
120mm	9EA133-06
140mm	9EA133-18*
170mm	9EA133-19
200mm	9EA133-12**

- * Wiper not available on some sets.
- ** Call for availability.
- Some sets contain several O-Rings for Single Stage or "S" Telescopic.
- Some internal Seal Sets available - please call.

Questions? Answers at...
 (866) CED-ELEV • (866) 233-3538
www.cedlevator.com

Otis—Cast Head (Mf'd. prior to 1974)

Plunger Size Actual (Nom)	Solid Packing Set Number
3 ⁷ / ₈ " (4)	9EA001-01
4 ³ / ₈ " (4 ¹ / ₂)	9EA001-02
5 ⁷ / ₁₆ " (5 ¹ / ₂)	9EA001-03
6 ¹ / ₂ " (6 ¹ / ₂)	9EA001-04
7 ¹ / ₂ " (7 ¹ / ₂)	9EA001-05
8 ¹ / ₂ " (8 ¹ / ₂)	9EA001-06
9 ¹ / ₂ " (9 ¹ / ₂)	6EA001-07
10 ⁵ / ₈ " (10 ¹ / ₂)	6EA001-08
12 ⁵ / ₈ " (12 ¹ / ₂)	6EA001-09
13 ³ / ₄ " (14)	6EA001-10
15 ³ / ₄ " (16)	6EA001-11

Otis—AP Welded (Mf'd. 1974-1993)

Plunger Size Actual (Nom)	Solid Packing Set Number
3 ⁷ / ₈ "	9EA114-05
3.93"	9EA114-01
4"***	9EA114-11
4 ³ / ₈ "*	9EA114-06
4.43"	9EA114-02
4 ⁷ / ₈ "*	9EA114-09
5"	9EA114-10
5 ⁷ / ₁₆ "*	9EA114-07
5.5"	9EA114-03
6 ¹ / ₂ "*	9EA114-08
6.56"	9EA114-04

- *These sizes typically associated with model mfg 1974 to 1993
- **Rarely used size in this type of head
- There are EXCEPTIONS (Newer units may have Cenco Lift tag; Gasket show not included, & During the transitional years (1992-1996) there are some "newer" models with "old" sizes and vice versa
- Older sizes typically associated with model mfg 1933 to 2012

Otis—AP Welded (Mf'd. after 1993)

Plunger Size	Solid Packing Set Number
3 ⁷ / ₈ "*	9EA114-05
3.93"	9EA114-01
4"***	9EA114-11
4 ³ / ₈ "*	9EA114-06
4.43"	9EA114-02
4 ⁷ / ₈ "	9EA114-09
5"	6EA114-10
5 ⁷ / ₁₆ "	6EA114-07
5.50"	6EA114-03
6 ¹ / ₂ "	6EA114-08
6.56"	6EA114-04

- * These sizes typically associated with model mfg 1974 to 1993.
- ** Rarely used size in this type of head.
- There are EXCEPTIONS (Newer units may have Cemco Lift tag; Gasket shown not included; During the transitional years (1992 to 1996), there are some "newer" models with "old" sizes and vice versa)
- Other sizes typically associated with model mfg 1993 to 2012

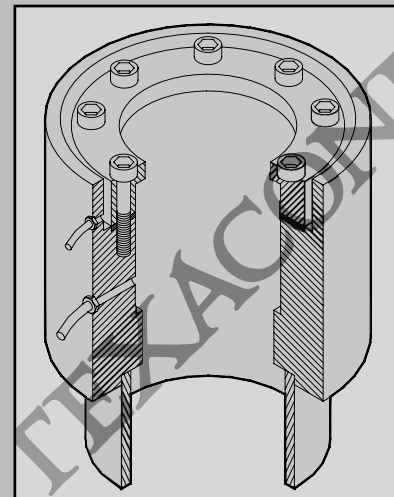
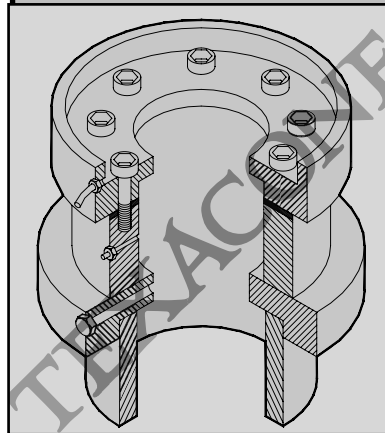
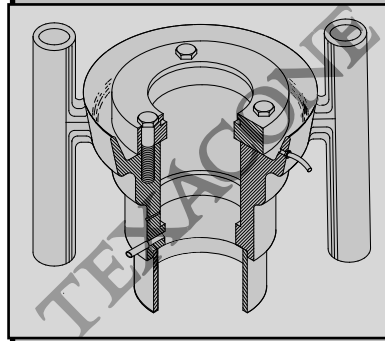

Illustrations are the property of Texacone and may not be reproduced without permission.

Questions? Answers at...
 (866) CED-ELEV • (866) 233-3538
www.cedelevator.com

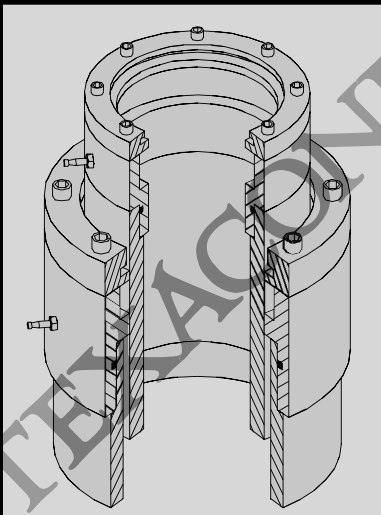
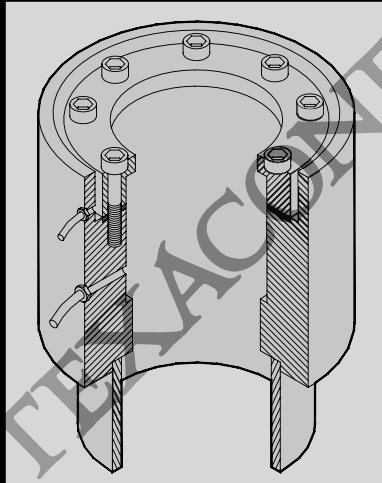

Otis

Otis—Holeless

Plunger Size	Solid Packing Set Number
2 ³ / ₄ "	9EA128-01
2.84"*	9EA128-02

- Early units had spacer plus a bearing; current packing set combines both into 1 piece
- 2³/₄" Holeless uses pop-in wiper
- * Very few of the earliest 2.84 units require soft pop-in wiper. Please call for assistance if you have one of those rare units.
- Usually need 2 set per car on Holeless Units.

Otis—Roped

Plunger Size	Solid Packing Set Number
3.93"*	9EA104-01
4.43"	9EA104-02
5.50"	9EA104-03

- Holeless/Roped

Otis—Telescopic

Plunger Size	Solid Packing Set Number
3.00/4.62"	9EA067-01
3.52/5.10"	9EA067-02
4.37/6.32"	9EA067-03
3.87/5.71"	9EA067-04
3.00/4.62"*	9EA067-05

- *Unit manufactured after 1977.

Otis/Cemco Plunger Lift Portaflex

Otis/Cemco

Plunger Size	Solid Packing Set Number
3 7/8"	9EA110-05
3.93"	9EA110-01**
4 3/8"	9EA110-06
4.43"	9EA110-02**
5 7/16"	9EA110-07
5.50"	9EA110-03**
6 1/2"*	9EA110-10
6.56"	9EA110-09**
6.56**	9EA110-11

- *These cylinder heads look like the Cemco-Flange head.
- **Wear ring and additional O-Ring included in these sets.

Plunger Lift

Plunger Size	STEEL	BRASS
	Solid Packing Set Number	Solid Packing Set Number
4"	9EA034-01	1A129-01
5"	9EA034-02	1A129-01
6"	9EA034-03	1A129-03
7"	9EA034-04	1A129-04,

Porta-flex (C.E.E.)

Plunger Size	Solid Packing Set Number*
1 3/4 / 2 3/4 / 3 3/4"	6EA149-01
2 1/4 / 3 / 4 1/4"	6EA149-02
3 / 4 / 5 1/2"	6EA149-03
3 1/2 / 4 1/4 / 6 1/4"	6EA149-04

- * Call for availability, uses Brass Gland

R & O—Cast Head

Plunger Size	Split Autopak Set Number*
4 3/8"	1AT090-01
4 1/2"	1AT090-02
5 7/16"	1AT090-03
5 1/2"	1AT090-04
6 1/2"	1AT090-05
8 1/2"	1AT090-06
10 1/2"	1AT090-07

- Manufactured prior to 1971.
- May require gasket (not included) if completely disassembled.

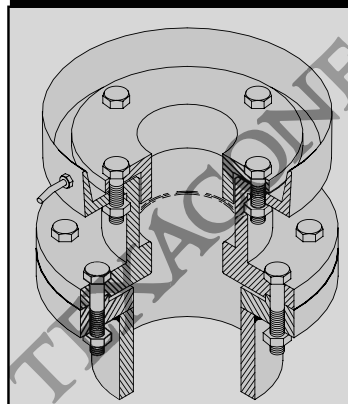
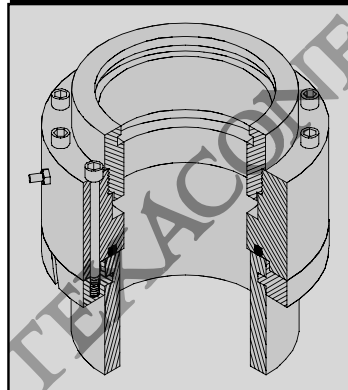
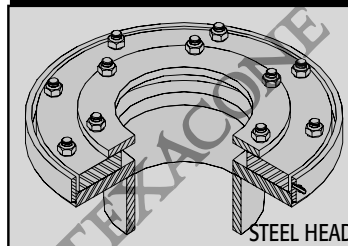
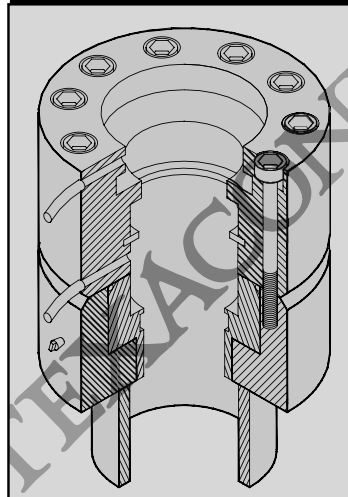

Illustrations are the property of Texacone and may not be reproduced without permission.

Questions? Answers at...
(866) CED-ELEV • (866) 233-3538
www.cedelevator.com

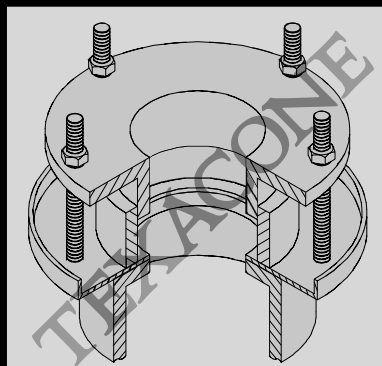
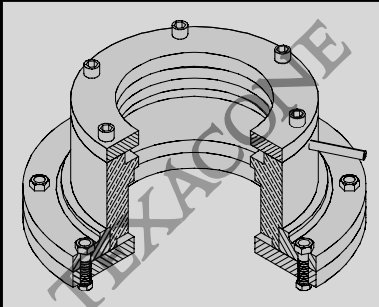
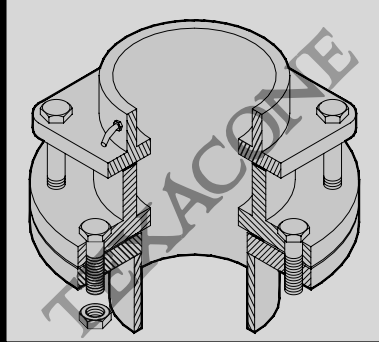

R&O Richmond San Jose

R & O—Model 71 & 76

Plunger Size	Solid Packing Set Number
4 ³ / ₈ "	9EA013-01
5 ⁷ / ₁₆ "	9EA013-02
6 ¹ / ₂ "	9EA013-03

- Model 71: manufactured 1971 to 1975
- Model 76: manufactured 1975 to 1978

Richmond

Plunger Size	Solid Packing Set Number
4 ³ / ₈ "	9EA142-01
5 ⁷ / ₁₆ "	9EA142-02
6 ¹ / ₂ "	9EA142-03

San Jose

Plunger Size	Packing Set Number
4 ¹ / ₂ "	1A093-01
5 ¹ / ₂ "	1A093-02
6 ¹ / ₂ "	1A093-03
7 ¹ / ₂ "	1A093-04
8 ¹ / ₂ "	1A093-05

- Packing Sets and Autopak are ³/₄ cross section.

Questions? Answers at...
 (866) CED-ELEV • (866) 233-3538
www.cedlevator.com

Schindler Southeastern

Schindler—MPH2 (Martin, D.L.)

Plunger Size	Solid Packing Set Number
3½"	9EA113-01
3¾"	9EA113-02
4"	9EA113-03*
4½"	9EA113-04*
5"	9EA113-05
5½"	9EA113-06
6"	9EA113-07
6½"	9EA113-08
7"	9EA113-09
8"	9EA113-10

- Manufactured since 1989 by D.L. Martin.
- Packing sets are ¼ cross section.
- Some units have been field retrofitted to accept ⅜ or ½ cross section seals. Please call for availability.
- Early units had (4) bolts, (2) rings. Later units had (2) bolts, (1) O-Ring
- Easily confused with Westinghouse MPH1 which was manufactured before 1989. Notice outside cylinder head wall is much shorter than MPH1.
- * These sizes have extra O-Ring for alternate cylinder size.

Schindler—Telescopic (321A & 330)

Plunger Size	Solid Packing Set Number
60mm	9EA130-01*
75mm	9EA130-02*
90mm	9EA130-03*

- *Only one Foot Piece O-Ring included per Multi-Stage set
- Inverted Cylinder
- See chart below for model number requirements.
- Drip ring collectors available for all stages
- Old piston bands may cause friction
- Typically Twin Post needs 2 sets per job (1 set per pack)

Solid Packing Set Number	Model Number			
	60-2Y	75-2Y	90-2Y	60-3Y 75-3Y
60mm	X			X
75mm	X	X		X X
90mm		X	X	X X
105mm			X	X

Southeastern (Manufactured in the 1960s)

Plunger Size	Solid Packing Set Number	Plunger Size	Solid Packing Set Number
4¾"	9EA007-01	7½"	9EA007-06
5"	9EA007-02	8½"	9EA007-07
5¼"***	6EA007-11	9½"	9EA007-08
5½"	9EA007-03	10⅝"	9EA007-09
6½"	9EA007-04	12⅝"	9EA007-10
6⅞"	9EA007-05	13⅞"*	9EA007-12
		15⅞"*	9EA007-13

- Number of bolts on head may vary; sometimes only (3).
- May require gasket (not included) if completely disassembled.
- May have SH, SE, or SF stamped on head.
- Older units have bronze gland and no wiper.
- Easily confused with EECO FJ. Check Bleeder valve.
- * These sizes use 1" cross section Autopak. Call for availability.
- ** Uses additional Lantern.

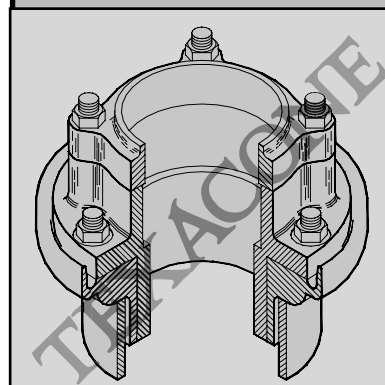
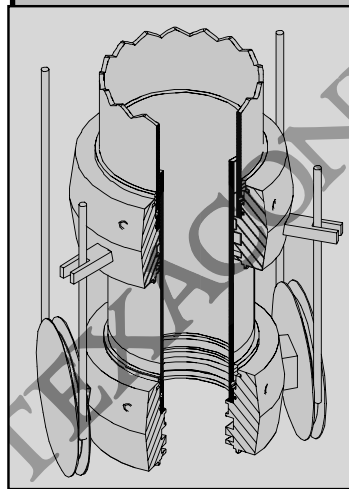
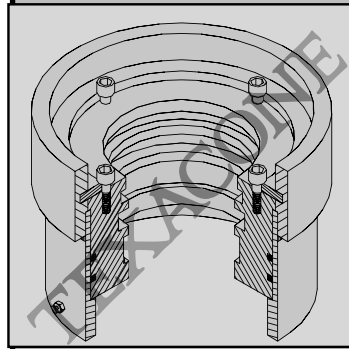

Illustrations are the property of Texacone and may not be reproduced without permission.

Questions? Answers at...
(866) CED-ELEV • (866) 233-3538
www.cedelevator.com

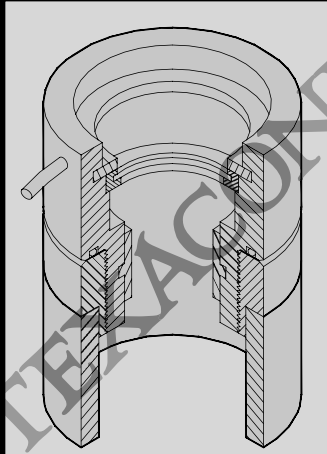
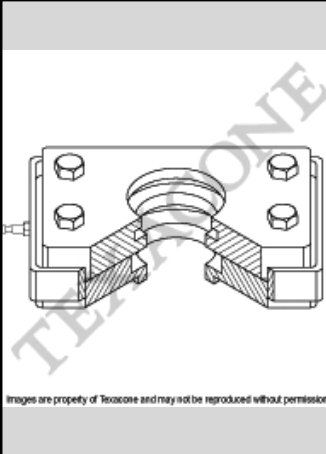

Images are property of Texacone and may not be reproduced without permission.

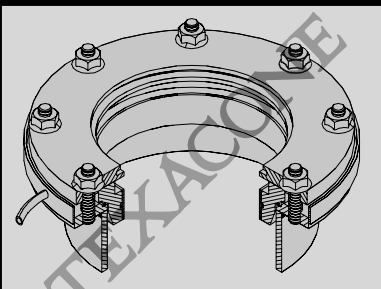
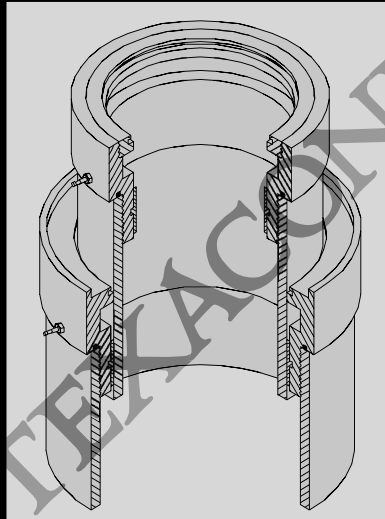

Thyssenkrupp [Dover]

Thyssenkrupp [Dover] Holeless

Plunger Size	Solid Packing Set Number
3" (2S)	9EA023-27
3 7/8" (3S)	9EA023-22
4 3/8" (4S)	9EA127-01**
5 7/16" (5S)	9EA127-02**
6 1/2" (6S)	9EA127-03**
7 1/2" (7S)	9EA127-04***
8 1/2" (8S)	9EA127-05***

- * These sizes manufactured after 2001
- ** Sets have extra O-Rings.
- *** Call for availability of O-Ring.
- Cimmaron is a common name for 3S Jack
- Some older units may not have groove for wiper.

Thyssenkrupp [Dover] Telescopic

Plunger Size	Solid Packing Set Number
2 1/2 / 3 3/4"	9EA023-28
3 / 4 1/4"	9EA023-29
2 1/2 / 3 3/4 / 5"	9EA023-33

- Call for availability of optional Wear Band Sets.

Thyssenkrupp—Rota U-Cup

Plunger Size	Solid Packing Set Number
3 7/8" (3S)	9EA023-22
4 3/8" (4S)	9EA127-01
5 7/16" (5S)	9EA127-02
6 1/2" (6S)	9EA127-03
7 1/2" (7S)**	9EA127-04
8 1/2" (8S)**	9EA127-05

- Manufactured as of 2005. Looks similar to Dover-Rota except uses flange type nuts and conventional U-cup seal
- All sets have extra O-Rings.
- 3 7/8" (3S) Rota head looks slightly different; made earlier.
- ** 7S and 8S use copper gasket, not O-ring. Not available.

Questions? Answers at...
 (866) CED-ELEV • (866) 233-3538
www.cedlevator.com

United

Plunger Size	Solid Packing Set Number
3 ⁵ / ₁₆ "	6EA033-01
4"	9EA033-20
4 ⁷ / ₁₆ "	6EA033-02
4 ¹ / ₂ "	9EA033-21
5"	9EA033-03
5 ¹ / ₂ "	9EA033-04
5 ⁹ / ₁₆ "	6EA033-27
6"	9EA033-13
6 ¹ / ₂ "	9EA033-05
6 ³ / ₁₆ "	6EA033-14
6 ⁵ / ₈ "	6EA033-06
7 ¹ / ₂ "	9EA033-16
7 ⁹ / ₁₆ "	6EA033-07
7 ⁵ / ₈ "	6EA033-17
8 ¹ / ₂ "	9EA033-18
8 ³ / ₁₆ "	6EA033-08
8 ⁵ / ₈ "	9EA033-19*

- * Wiper is different than shown in picture
- Lantern supplied with set but reuse existing lantern bearing if possible.
- Some sets contain several O-Rings for different cylinder types and sizes.
- Usually requires (1) seal for 5⁹/₁₆" and under; (2) seals for 6" and over. All sets shown contain (2) seals.
- Lanterns are individually sized by United when manufacturing.

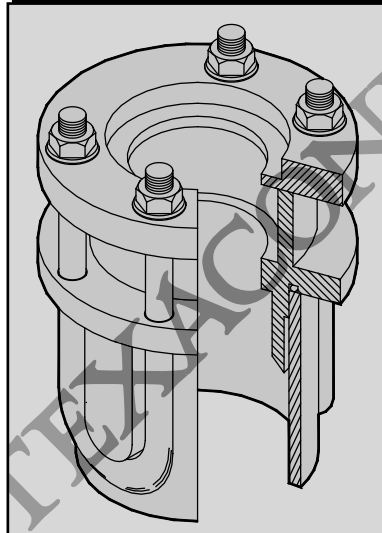
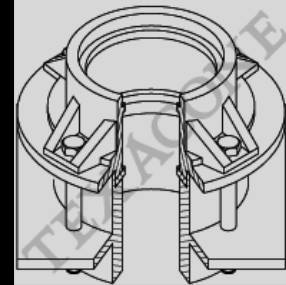
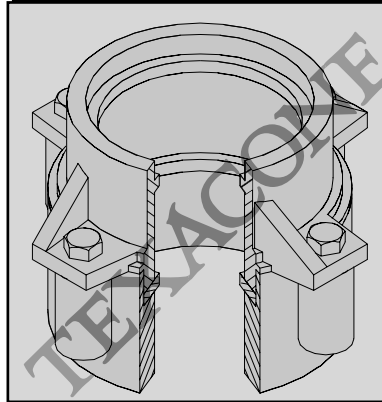

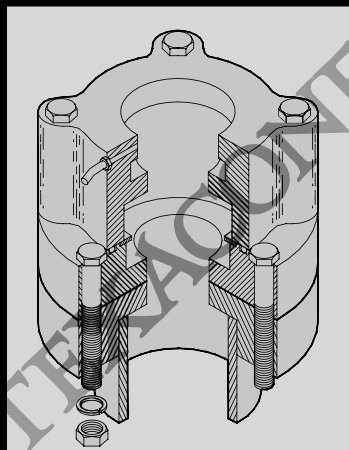
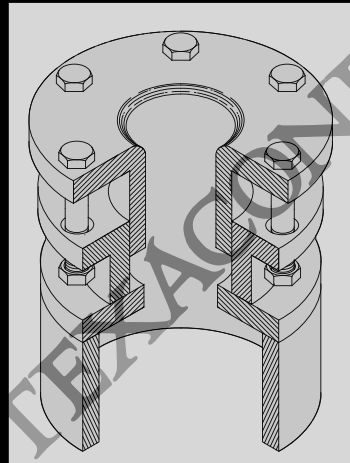
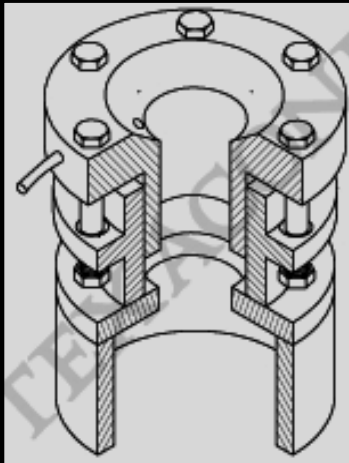
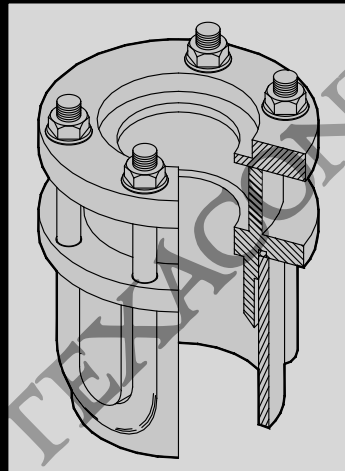

United U.S. Elevator

United—Holeless

Plunger Size	Cross Section	Solid Packing Set Number
2 ³ / ₈ "	1/2	6EA033-09
2 ⁷ / ₈ "	1/2	6EA033-10
3 ¹ / ₂ "*	3/8	9EA033-11
3 ¹ / ₂ "**	7/16	6EA033-12
3 ¹ / ₂ "***	1/2	9EA033-22
4"	1/2	9EA033-23
4 ¹ / ₂ "	1/2	9EA033-24

- * Manufactured before April 1988.
- ** Manufactured from April 1988 to Sept 2000.
- *** Manufactured after Oct 2000.
- **** Wiper not available.
- Some sets contain several O-Rings for different cylinder types and sizes.

U.S.—Aluminum

Plunger Size	Split Autopak Set Number
3 ⁷ / ₈ "	1AT118-01
4"	1AT118-02
4 ¹ / ₂ "	1AT118-03
5"	1AT118-04
5 ¹ / ₂ "	1AT118-05
6"	1AT118-06
7"	1AT118-07

- * Autopak is recommended packing.
- Solid packing set available 6EA116-XX.
- Manufactured prior to 1983.
- May have more than (4) bolts.

U.S.—MT

Plunger Size	Solid Packing Set Number
4"	6EA012-01
4 ¹ / ₂ "	6EA012-02
5"	6EA012-03
5 ¹ / ₂ "	6EA012-04
6"	6EA012-05
6 ¹ / ₂ "	6EA012-06
7"	6EA012-07

- Manufactured from 1983 to 1986.

Questions? Answers at...
 (866) CED-ELEV • (866) 233-3538
www.cedlevator.com

U.S.—Econohead

Plunger Size Actual (Nom)	Solid Packing Set Number
2.81" (2 ⁷ / ₈)	9EA145-01
3.72" (3 ³ / ₄)	6EA145-02
3.95" (4)	9EA145-03
4.45" (4 ¹ / ₂)	9EA145-04
4.97" (5)	9EA145-05
5.49" (5 ¹ / ₂)	9EA145-06
5.97" (6)	9EA145-07*
6.49" (6 ¹ / ₂)	9EA145-08
6.53" (6 ⁵ / ₈)	9EA145-09

- * Only seals and O-Ring available.
- Units manufactured prior to 1990 use only (1) seal.
- Plunger diameters may be up to .020 larger than dimensions shown on table
- Looks similar to US Bench Pack

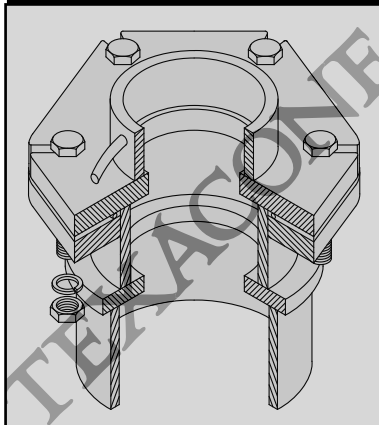

U.S.—Bench Pack—BPE

Plunger Size Actual (Nom)	Solid Packing Set Number
2.81" (2 ⁷ / ₈)	9EA111-05*
3.44" (3 ¹ / ₂)	9EA111-06*
3.95" (4)	9EA111-01
4.44" (4 ¹ / ₂)	9EA111-02
5.49" (5 ¹ / ₂)	9EA111-03
6.56" (6 ⁵ / ₈)	9EA111-04
8.52" (8 ¹ / ₂)	9EA111-07*

- * Bearing not supplied. Use split wear ring only.
- Packing Sets include parts for both Bench Pack & PS97.
- Manufactured from 1994 to 1997.
- Plunger diameters may be up to .020 larger than dimensions shown on table
- Looks similar to US Econohead

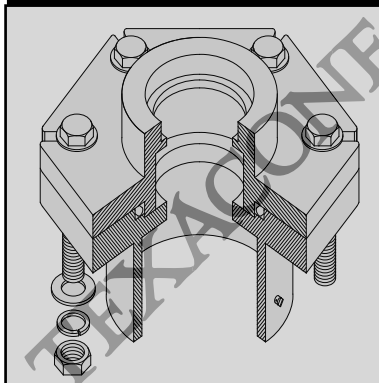

U.S.—PS97 & Roped

Plunger Size Actual (Nom)	Solid Packing Set Number
2.81" (2 ⁷ / ₈)	9EA111-05*
3.44" (3 ¹ / ₂)	9EA111-06*
3.95" (4)	9EA111-01
4.44" (4 ¹ / ₂)	9EA111-02
5.49" (5 ¹ / ₂)	9EA111-03
6.56" (6 ⁵ / ₈)	9EA111-04
8.52" (8 ¹ / ₂)	9EA111-07*

- * Bearing not supplied. Use split wear ring only.
- Packing Sets include parts for both Bench Pack & PS97.
- Plunger diameters may be up to .020 larger than dimensions shown on table
- Bench pack manufactured from 1994 to 1997.
- Looks similar to US Econohead.

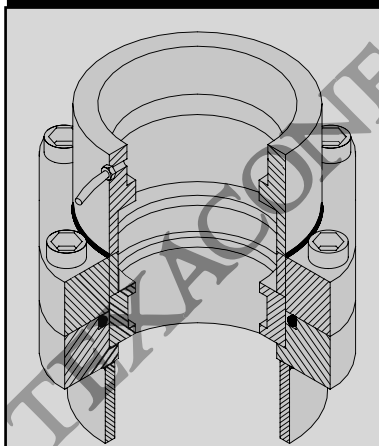

Illustrations are the property of Texacone and may not be reproduced without permission.

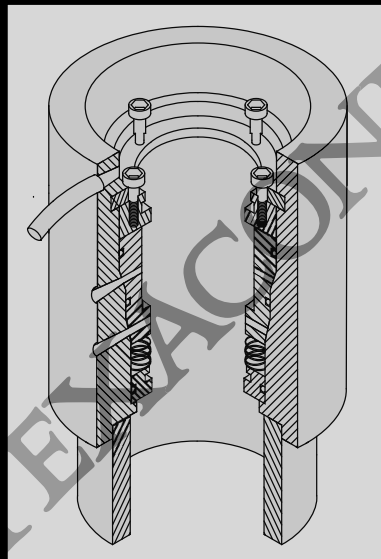
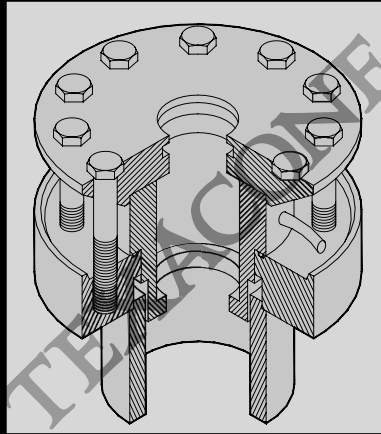

Westinghouse

Westinghouse— Bolted (E Series)

Plunger Size	Solid Packing Set Number
4"	9EA117-01
4½"	9EA117-02
5½"	9EA117-03
6"	9EA117-04
6½"	9EA117-05

Westinghouse—MPH1

Plunger Size	Solid Packing Set Number
3½"	9EA025-01
3¾"	9EA025-02
4"	9EA025-03
4½"	9EA025-04
5½"	9EA025-05
6"	9EA025-06
6½"	9EA025-07
7"	9EA025-08
8"	9EA025-09

- Easily confused with Schindler MPH2 which has been manufactured since 1989. Notice outside cylinder head wall is much longer than MPH2.
- 3rd O-Ring is to be positioned on OD groove in bottom striker plate if it is removed.
- Remove bottom striker plate in cases of plunger damage.
- There are (4) grooves on OD packing sleeve. ONLY (2) are O-Ring grooves.
- Grooves with port holes are NOT for O-Rings.

Questions? Answers at...

(866) CED-ELEV • (866) 233-3538
www.cedlevator.com

White-Evans Winter & Bain

White-Evans

Plunger Size	Solid Packing Set Number*
4 ³ / ₈ "	6EA125-01
4 ¹ / ₂ "	6EA125-10
5 ³ / ₈ "	6EA125-02
5 ⁷ / ₁₆ "	6EA125-03
5 ¹ / ₂ "	6EA125-04
6 ¹ / ₂ "	6EA125-05
7"	6EA125-06
7 ¹ / ₂ "	6EA125-07
8 ¹ / ₂ "	6EA125-08
10 ⁵ / ₈ "	6EA125-09

- Some units may require only one seal.
- Manufactured in the 1960s.
- May require gasket (not included) if completely disassembled.

Winter & Bain

Plunger Size	Solid Packing Set Number
2 ¹ / ₂ "	9EA006-01
3"	9EA006-19
3 ¹ / ₂ "	9EA006-02
3 ⁷ / ₈ "	9EA006-20
4"	9EA006-15
4 ³ / ₈ "	9EA006-03
4 ¹ / ₂ "	9EA006-21
5"	9EA006-04
5 ⁷ / ₁₆ "	9EA006-05
5 ¹ / ₂ "	9EA006-06
6"	9EA006-14
6 ¹ / ₂ "	9EA006-07
6 ⁹ / ₁₆ "	9EA006-08
7"	9EA006-09
7 ¹ / ₂ "	9EA006-10
8"	9EA006-16
8 ¹ / ₂ "	9EA006-11
9"	9EA006-17
9 ¹ / ₂ "	9EA006-12
10"	9EA006-18
10 ¹ / ₂ "	9EA006-22
10 ⁵ / ₈ "	9EA006-13

- 10" casings and above may require gasket if completely disassembled. Not available.
- Plunger > 6" normally has round cover plate.

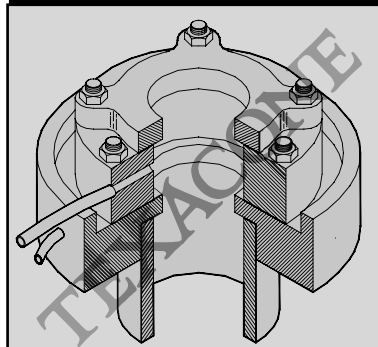
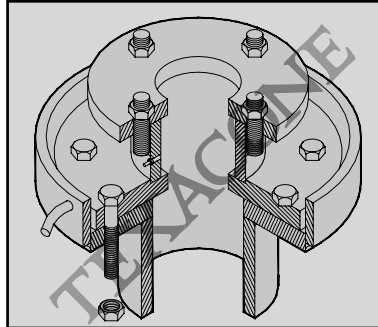

Illustrations are the property of Texacone and may not be reproduced without permission.

Questions? Answers at...
 (866) CED-ELEV • (866) 233-3538
www.cedelevator.com

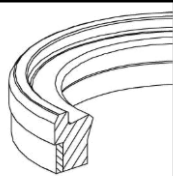
1R - HT - SPLIT Hi Temp Worm Gear Seal

- New "HT" elastomer is a very high temperature, abrasion resistant compound.
- Outlasts standard oil seal compounds in demanding environments.
- Outer fabric component with Fabrilok assures snug press fit into housing to eliminate spinning or "walkout".
- Lip design provides light sealing pressures with excellent flexibility to suppress heat build up with eccentric loads.
- Incorporates unique dove-tailed split joint for perfect lip alignment.

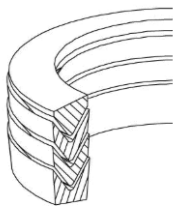
10PA - SPLIT Worm Shaft Packing

- For use on machines incorporating "Packing Boxes", MUST be compressed.
- Nested Vee design provides excellent split sealing without binding and allows for occasional adjustments to extend packing life.
- Excellent for worn shafts.
- Elastomer blend reduces heat build up to ensure long packing life.

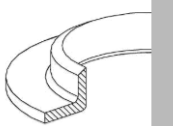
1M, 5E - SPLIT Sheave/Spider Seal

- Prevents oil mist from coating machine and surrounding area.
- Designed specifically for each manufacturer's machine.
- Split for easy installation.

Traction Machine Packings

Armor

Machine Number	Packing Dimensions	Texacone Part Number
#1	1.500" x 2.500" x .828"	10PA01-29*
#2	1.750" x 2.750" x .828"	10PA01-30 (1)*
#3 OLD	1.875" x 2.875" x 1.297"	10PA01-31*
#3 INT	1.938" x 3.063" x 1.359"	10PA01-32*
#3 FIN	1.938" x 2.875" x 1.266"	10PA01-33 (2)*
#4	2.000" x 3.000"	1R020
#5	2.750" x 3.750"	1R081

- * Shims included with sets.
- (1) Substitute Worm Gear seal part number 1R059
- (2) Substitute Worm Gear seal part number 1R012

Dover

Machine Number	Packing Dimensions	Manufacturer Part Number	Texacone Part Number
GD1*	2.000" x 3.000" Worm	-	1R020
GD1*	2.000" x 3.250" Worm	-	1R021
GD2*	2.000" x 3.000" Worm	-	1R020
GD2*	2.000" x 3.250" Worm	-	1R021
GD45	3.125" x 4.250" Inner	9752146	1R103 CR
GD45	1.749" x 2.650" Worm	9752110	1R043
GD45	5.125" x 7.000" Spider	9767897	5E006
GD50	3.125" x 4.250" Inner	9752146	1R103 CR
GD50	1.749" x 2.650" Worm	9752110	1R043
GD75	3.125" x 4.250" Inner	9752146	1R103 CR
GD75	1.749" x 2.650" Worm	9752110	1R043
GD105	7.125" x 8.625" Spider	9825526	5E004
GD105	4.500" x 5.500" Inner	9727346	1R048 SOLID
GD105	2.345" x 83.220" Worm	9825514	1R002
GD200	2.815" x 3.825" Worm	9751122	1R113
GD240	2.345" x 3.220" Worm	9825514	1R002
GD240	5.000" x 6.250" Inner	9824479	1R101 N
GD240	8.500" x 10.250" Spider	9808760	5E005
GD300	2.815" x 3.825" Worm	9751122	1R113

- * Requires both seals
- NOTE: CR, N, and G designate solid seals.

Fujitec

Machine Number	Packing Dimensions	Manufacturer Part Number	Texacone Part Number
-	50mm x 72mm	TM50C	1R114
	60mm x 90mm	EM81	1R119

Questions? Answers at...
 (866) CED-ELEV • (866) 233-3538
www.cedlevator.com

Traction Machine Packings

Houghton Machines

Machine Number	Packing Dimensions	Texacone Part Number
E	2.000" x 2.750" x 2.250"	10PA01-20
EK	2.750" x 3.750"	1R081
H	1.438" x 2.250" x 1.688"	10PA01-21
O	1.438" x 2.250" x 1.625"	10PA01-22
R	1.750" x 2.500" x 1.750"	10PA01-23
OH	2.500" x 3.500"	1R100
N	3.188" x 4.250" x 2.500"	10PA01-24
L	2.688" x 3.750" x 2.500"	10PA01-25
K	2.188" x 3.250" x 2.313"	10PA01-26
EKU	2.750" x 3.750"	1R081

Hollister & Whitney

Machine Number	Packing Dimensions	Texacone Part Number
34	4 ⁷ / ₈ " x 6 ⁷ / ₈ " Sheave	1M253
43/44	5 ³ / ₈ " x 7 ³ / ₈ " Sheave	1M244
43/44	1.688" x 2.563" Worm	1R062
53/54	7" x 9" Sheave	1M252
53/54	1.938" x 2.875" Worm	1R079
63/64	8 ¹ / ₄ " x 11" Sheave	1M240
63/64	2.188" x 3.000" Worm	1R052
74	12" x 14" Sheave	1M251

Mitsubishi

Packing Dimensions	Reference Number	Texacone Part Number
70mm x 100mm	-	1R120
80mm x 105mm	-	1R121

Montgomery

Machine Number	Packing Dimensions	Manufacturer Part Number	Texacone Part Number
207E	1.938" x 3.194"	9096-017	1R086
207E	1.125" x 1.832"	9096-021	1R049N
207E	2.625" x 3.548"	9096-047	1R095N
208E	1.938" x 3.194"	9096-017	1R086
208E	1.125" x 1.832"	9096-021	1R049N
208E	4.000" x 5.004"	9096-024	1R031
210E	2.438" x 3.548"	9096-005	1R047
210E	4.500" x 5.756"	9096-046	1R094N
214E	2.438" x 3.548"	9096-005	1R047
214E	4.375" x 5.756"	9096-029	1R093N
215E	2.438" x 3.548"	9096-005	1R047
215E	2.938" x 4.003"	9096-008	1R039
215E	4.375" x 5.756"	9096-029	1R093N

* Note: N designates solid seal, otherwise supplied as SPLIT unless specifically requested SOLID.

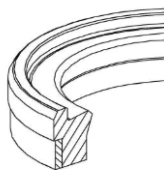

1R - HT - SPLIT Hi Temp Worm Gear Seal

- New "HT" elastomer is a very high temperature, abrasion resistant compound.
- Outlasts standard oil seal compounds in demanding environments.
- Outer fabric component with Fabrilok assures snug press fit into housing to eliminate spinning or "walkout".
- Lip design provides light sealing pressures with excellent flexibility to suppress heat build up with eccentric loads.
- Incorporates unique dove-tailed split joint for perfect lip alignment.

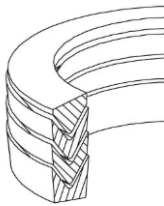

10PA - SPLIT Worm Shaft Packing

- For use on machines incorporating "Packing Boxes", MUST be compressed.
- Nested Vee design provides excellent split sealing without binding and allows for occasional adjustments to extend packing life.
- Excellent for worn shafts.
- Elastomer blend reduces heat build up to ensure long packing life.

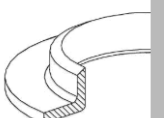

1M, 5E - SPLIT Sheave/Spider Seal

- Prevents oil mist from coating machine and surrounding area.
- Designed specifically for each manufacturer's machine.
- Split for easy installation.

Illustrations are the property of Texacone and may not be reproduced without permission.

Questions? Answers at...
 (866) CED-ELEV • (866) 233-3538
www.cedlevator.com

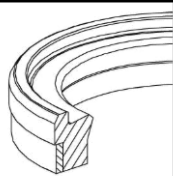

1R - HT - SPLIT Hi Temp Worm Gear Seal

- New "HT" elastomer is a very high temperature, abrasion resistant compound.
- Outlasts standard oil seal compounds in demanding environments.
- Outer fabric component with Fabrilok assures snug press fit into housing to eliminate spinning or "walkout".
- Lip design provides light sealing pressures with excellent flexibility to suppress heat build up with eccentric loads.
- Incorporates unique dove-tailed split joint for perfect lip alignment.

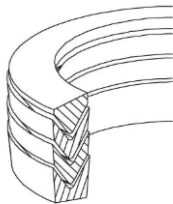

10PA - SPLIT Worm Shaft Packing

- For use on machines incorporating "Packing Boxes", MUST be compressed.
- Nested Vee design provides excellent split sealing without binding and allows for occasional adjustments to extend packing life.
- Excellent for worn shafts.
- Elastomer blend reduces heat build up to ensure long packing life.

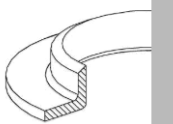

1M, 5E - SPLIT Sheave/Spider Seal

- Prevents oil mist from coating machine and surrounding area.
- Designed specifically for each manufacturer's machine.
- Split for easy installation.

Traction Machine Packings

Otis

Machine Number	Packing Dimensions	Manufacturer Part Number	Texacone Part Number
17CT	1.938" x 2.875"	33AA1	1R079
22CT	2.000" x 3.000"	33D29	1R020
22CT OLD	2.000" x 3.250"	33P2	1R021
29CT	3.000" x 4.500"	33D26	1R019
	6.875" x 7.875"	33D31	1R077
	8.250" x 9.500"	33D27	1R096
	5.000" x 6.000"	33D5	1R091
	5.313" x 6.313"	33D23	1R084
	5.313" x 6.250"	33D20	1R105

Otis Worm Shaft Packing

Packing Dimensions	Manufacturer Part Number	Texacone Part Number
1.000" x 1.750" x 1.250"	182A1	10PA01-37
1.313" x 2.063" x 1.375"	182A2	10PA01-38
1.583" x 2.583" x 1.687"	182A3	10PA01-39
1.875" x 3.125" x 2.062"	182A4	10PA01-40
2.125" x 3.375" x 2.625"	182A5	10PA01-41
2.250" x 3.500" x 2.000"	182A6	10PA01-42
2.500" x 3.750" x 1.937"	182A7	10PA01-43
3.500" x 4.500" x 2.312"	182A8	10PA01-44
0.625" x 1.406" x 1.1258"	182A9	10PA01-45
1.188" x 1.688" x 1.625"	182A10	10PA01-46
1.313" x 1.875" x 1.062"	182A11	10PA01-47
2.000" x 3.000" x 1.312"	182A12	10PA01-48
1.813" x 2.813" x 1.500"	182A13	10PA01-49
1.438" x 2.438" x 1.000"	182A14	10PA01-50
1.563" x 2.563" x 1.375"	182A15	10PA01-51
3.625" x 5.125" x 2.312"	182A16	10PA01-52
1.875" x 3.125" x 1.687"	182A17	10PA01-53
1.875" x 3.000" x 2.625"	182A18	10PA01-54
2.500" x 3.750" x 1.625"	182A19	10PA01-55

Park Manufacturing

Packing Dimensions	Texacone Part Number
1.938" x 3.188"	1R017
2.188" x 3.188"	1R018

F.S. Payne

Machine Number	Packing Dimensions	Texacone Part Number
400	2.500" x 3.500"	1R100
B	1.373" x 2.373"	1R061
300	1.875" x 2.875"	1R013

Questions? Answers at...
(866) CED-ELEV • (866) 233-3538
www.cedlevator.com

Traction Machine Packings

U.S. Elevator

Packing	Texacone
Dimensions	Part Number
2.125" x 3.188"	1R027

Watson

Packing	Texacone
Dimensions	Part Number
1.688" x 2.563"	1R062
2.188" x 3.188"	1R063

Westbrook/Southeastern

Machine Number	Packing Dimensions	Texacone Part Number
7	1.625" x 2.438" x 2.000"	10PA01-34
22, 26	2.000" x 2.813" x 3.000"	10PA01-35
31	2.438" x 3.250" x 4.000"	10PA01-36

Westinghouse

Machine Number	Packing Dimensions	Manufacturer Part Number	Texacone Part Number
18	1.750" x 3.188" Worm	X30ES1H13	1R007
18*	2.563" x 3.750" Geared	X30ES1H12	1R050
18	6.855" x 8.500" Sheave	6918C45H01	1M139
27	2.125" x 3.140" Worm	R7311H23	1R115
27*	2.750" x 3.750" Geared	X30AS1H11	1R081
27*	2.75" x 3.50"(0-2-1) Geared	M32427H06	10PA01-56
28	2.500" x 3.500" Worm	X30ES1H19	1R100
28*	3.688" x 4.750" Geared	X30ES1H15	1R022
28	8.125" x 9.250" Sheave	6917C89H01	1M130
31	2.125" x 3.140" Worm	R7311H23	1R115
37	2.438" x 3.438" Worm	R7311H17	1R006
37*	3.25" x 4.25"(0-2-1) Geared	M3427H01	10PA01-57
38	3.125" x 4.250" Worm	X30ES1H20	1R004
38*	4.500" x 5.500" Geared	X30ES1H18	1R048
38	4.000" x 5.000" Worm	R7311H25	1R031
38	9.750" x 11.30" Sheave	2890C79H01	1M057
57	3.240" x 4.250" Worm	X30ES1H09	1R005
57*	4.00" x 5.00"(0-2-1) Geared	M3427H02	10PA01-58
58 NEW	3.250" x 4.500" Worm	X30ES1H14	1R028
58 OLD	3.240" x 4.250" Worm	X30ES1H09	1R005
61	3.240" x 4.250" Worm	X30ES1H09	1R005
81	4.000" x 5.000" Worm	R7311H25	1R031
18	Machine Kit	6918C44G02	1K006
28	Machine Kit	6917C91G02	1K005
38	Machine Kit	2900C27G02	1K004

* Geared Center - also called Pedestal, A-Frame

Illustrations are the property of Texacone and may not be reproduced without permission.

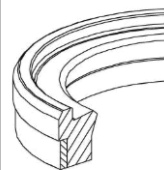

1R - HT - SPLIT Hi Temp Worm Gear Seal

- New "HT" elastomer is a very high temperature, abrasion resistant compound.
- Outlasts standard oil seal compounds in demanding environments.
- Outer fabric component with Fabrilok assures snug press fit into housing to eliminate spinning or "walkout".
- Lip design provides light sealing pressures with excellent flexibility to suppress heat build up with eccentric loads.
- Incorporates unique dove-tailed split joint for perfect lip alignment.

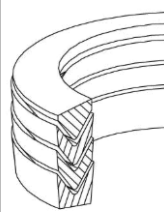

10PA - SPLIT Worm Shaft Packing

- For use on machines incorporating "Packing Boxes", MUST be compressed.
- Nested Vee design provides excellent split sealing without binding and allows for occasional adjustments to extend packing life.
- Excellent for worn shafts.
- Elastomer blend reduces heat build up to ensure long packing life.

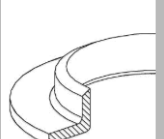

1M, 5E - SPLIT Sheave/Spider Seal

- Prevents oil mist from coating machine and surrounding area.
- Designed specifically for each manufacturer's machine.
- Split for easy installation.

Questions? Answers at...
(866) CED-ELEV • (866) 233-3538
www.cedelevator.com

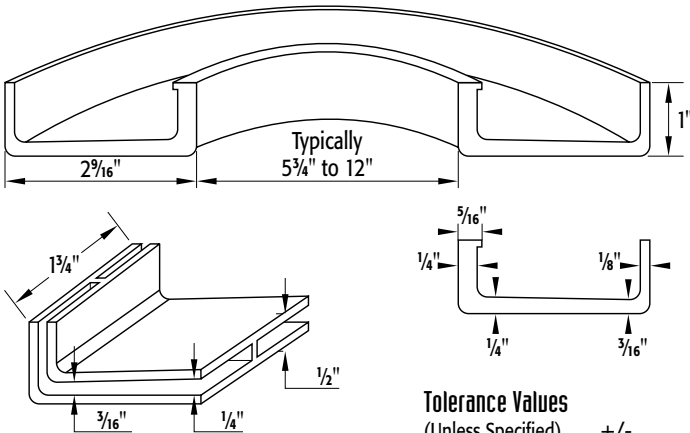

Joint Splice
1/8" Material

Tolerance Values
(Unless Specified)

+/-	
Decimal	.030
Fractions	1/32
Angles	2
Perpendicular	1/32
Parallel	1/32

Part Number	Cylinder Diameter	Cylinder Circumference
DR-1	5 3/4" to 7"	18" to 22"
DR-2	7" to 8 1/2"	22" to 26"
DR-3	8 1/2" to 10"	26" to 31"
DR-4	10" to 12"	31" to 37 1/2"

Drip Rings (Hydraulic Fluid Containment)

Contain leaking fluid with Drip Rings for Hydraulic Elevators

Drip Ring Features:

- Installation can be accomplished by one mechanic in approximately 15 minutes.
- The only tools needed: utility knife, marker, straight edge and screwdriver.
- Manufactured and molded from high quality, durable, oil-resistant materials.
- Oversized drain to resist clogging
- Fits cylinders from 5.75" through 12" in diameter (smaller sizes by special order).

Package Features:

- Drip Ring packages come with a complete installation kit containing detailed instructions, fittings, drain tubing, clamp, and sealant, all of the materials necessary for a quick, simple leak-free installation.

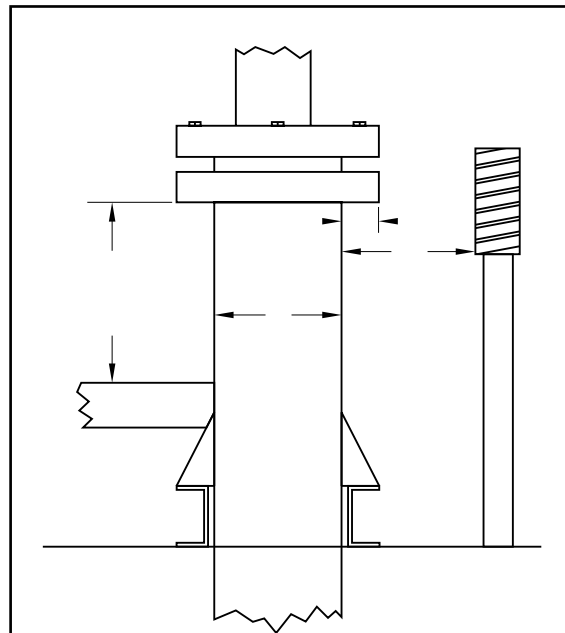

One Easy Measurement for the Drip Ring:

- A = Circumference or diameter in inches of the cylinder where the ring will be installed
- B = Maximum overhang of the packing head from the cylinder (3 3/4")
- C = Minimum side clearance (4")

Packing Box Worksheet

Information Needed:

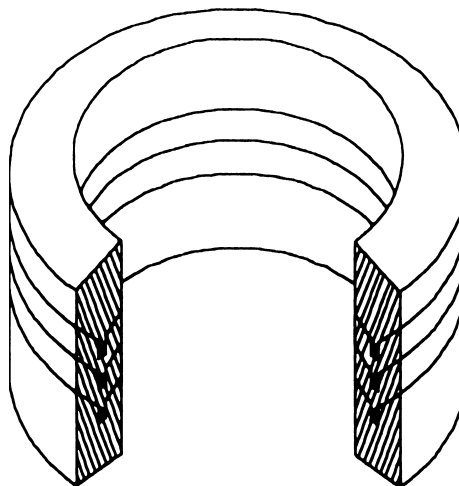
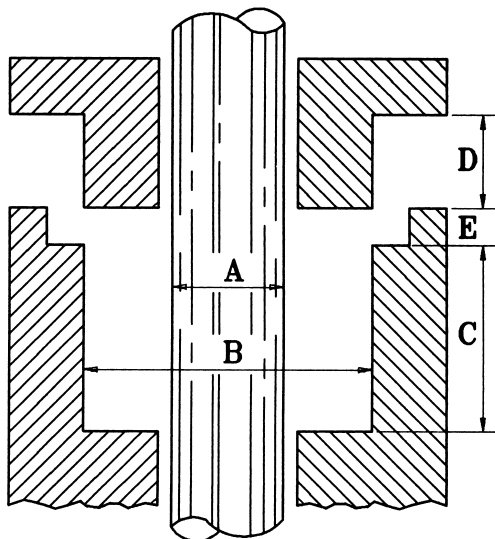

Standard Elevator Packing Box

Elevator Packing Box with Oil Groove

Jack Identification (Mfgr's): _____

Manufacturer of Jack: _____

(A) Plunger Diameter _____

(A) Plunger Diameter _____

(B) Box Bore _____

(B) Box Bore _____

(C) Depth of Box: _____

(C) Depth of Box: _____

(D) Length of Gland Neck _____

(D) Length of Gland Neck (when in box) _____

Notes: _____

Company: _____

Phone # _____

By: _____

Date: _____

Master copy – Please make a photocopy



Accessories

Complete Packing Replacement Kit

The Kit contains: The Packing Replacement kit is a complete set of unique tools to quickly replace and install seal components in hydraulic cylinders or traction machines. Exclusive tools prevent damage to precision equipment and seal components. All contained in a durable snap-tight case and supplied with detailed picture instructions.

The Texacone Packing Kit Contains:

- Diameter Tape
- Packing Installation Tool *
- Palm Saver Cap *
- Premium Screw Tips *
- Rigid Screw Tip Extensions *
- T-Style Pullers
- Oil Seal installation Dowel

* Exclusive Texacone Parts

Part Number	Description
1RA018	Packing Replacement Kit
DT	Diameter Tape Only

Jack's Green Slime

A ¼-ounce tube of Jack's Green Slime comes with every packing kit. Also available in 5oz. jars with brush top, and 1lb. grease cartridge size.

Part Number	Description
JGS-5OZ	Green Slime 5oz. jar
JGS-CASE	Green Slime Case, 12-5oz. jars
JGS-1LB	Green Slime 1lb. Grease Cartridge

Sanding Sleeve

Plungers used in the elevator industry are typically mild steel tubing that can be scratched and easily worn over time. Scratches, burrs and formations of rust shorten seal life and cause significant leakage. Pistons that have been worn smooth will not allow an oil film to aid in the lubrication of the seal, resulting in poor ride performance. The Texacone Sanding Sleeve was specifically developed to refinish plungers and return them to a factory-like finish. The Sanding Sleeve simply bolts to existing cylinder head hardware and is clamped around the plungers. It is reusable, only needing to be relined with abrasive paper to be put back in action.

The Sanding Sleeve paper kit is recommended and comes with assorted abrasive paper grits, cleaning solvent, contact cement and instructions on how to reline the Sanding Sleeve for continued use.

For deeper scratches and misaligned joints, use the Texacone Sure-fill Repair Kit (opposite page). Remember to add new packing after every use of the Sanding Sleeve to ensure trouble-free performance.

- Please call with plunger size for part number and availability.

Questions? Answers at...
 (866) CED-ELEV • (866) 233-3538
 www.cedlevator.com

Accessories

Sure-Fill Repair Kit

The sure way to fill scores and bad joints

Permanently repair piston damage at a fraction of the cost of replacement. Everything you need to do the job right comes in a convenient carrying case, so you never have to worry about lost parts, and refills are available.

- Excellent adhesion because our unique flux enables the solder filler to bond permanently to the repair area, and is impervious to oil, pressure and vibration.
- Solder filler has heat conduction properties similar to steel plungers so the repair will not crack or peel off like plastic fillers.
- The final repair will be undetectable with a smooth surface for better sealing and lower friction.

Part Number	Description
1RA020	Sure-Fill Repair Kit

Aligning System

Quick, accurate and easy cylinder alignment in minutes instead of hours. Eliminates the problems caused by out-of-plumb jacks and casing doglegs.

- Mechanically centered vapor proof light creates a highly visible halo of light to indicate when perfect alignment is achieved.
- Compact carrying case is self-contained and allows for portability and quick assembly.
- Works on 110V AC and on casings up to 12" in diameter. Extensions available for diameters over 12"
- Rails are not required to be installed, allowing the cylinder to be aligned before the structure is put up, saving time and expense.

Part Number	Description
1PB001	Cylinder Aligning System

O-Ring Splicing Kit

Create custom O-Rings in the field without waiting on replacement parts, and achieve a factory fit in minutes. (For use only with O-Rings in static applications.)

The Kit contains:

- Five sizes of O-Ring cord stock ($\frac{1}{16}$, $\frac{3}{32}$, $\frac{1}{8}$, $\frac{3}{16}$ and $\frac{1}{4}$) in lengths of seven feet.
- Splicing jig that makes cutting and joining O-Ring cord a snap.
- Rapid set adhesive for permanent bonds.
- Cutting blade.
- Handy carrying case.

Part Number	Description
IRA027	O-Ring Splicing Kit
IRA028	O-Ring Splicing Kit - Metric

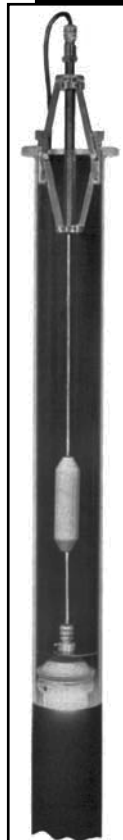
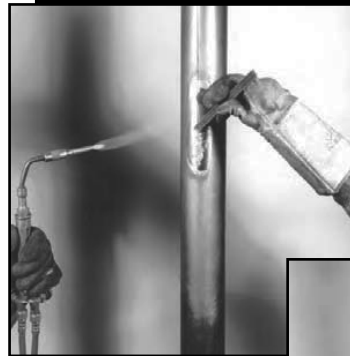

Questions? Answers at...
 (866) CED-ELEV • (866) 233-3538
www.cedelevator.com



Accessories

Texacone Technician's Head ID Handbook

The Identification system that Texacone made famous is also available in a convenient pocket-sized handbook. This handbook is indispensable for field personnel who need to order the correct packing set the first time. You can quickly identify the cylinder head by manufacturer and model type and select the corresponding packing set, all without disassembling the unit.

Detailed CAD drawings faithfully duplicate features of each manufacturer's head for easy identification. Handbook includes many hard-to-identify cylinder heads that haven't been produced in years.

The handbook is printed on durable, laminated pages that resist fading and stand up to grease, oil and years of use.

The original is still the best and most complete available.

Part Number **HB**

DOWNLOAD THE TEXACONE APP FOR IPHONE & ANDROID

Texacone's Jack head ID app equips elevator professionals to confidently identify a hydraulic cylinder head on the job site. Now all that critical information is available on your phone without the need for web access, even down in the pit! The app uses the same patent pending Interactive Elevator Cylinder Head ID system as found on Texacone's website.

- Ability to scroll through the entire Cylinder Head gallery
- Search by head attributes, packing set number, and manufacturer name
- Narrow down results by selecting Plunger Diameter

Questions? Answers at...

(866) CED-ELEV • (866) 233-3538
www.cedlevator.com

PEELLE PARTS GUIDE

23

In this Section

Parts by Category	23.2
Parts by Year	23.2-3

Landing Door

Guide Shoes	23.5
Interlocks	23.6
Unlocking Devices	23.6
Interlock Keepers	23.7
Retiring Cams	23.8
Chains & Panel Parts	23.9
Operators	23.10
Sheaves & Limits	23.11
Operator Motor Replacement	23.12

Car Gate/Car Door

Panel, Shoes	23.13
Counterweight	23.13
Gate Contacts	23.13
Chains & Panel Parts	23.14
Bumpers and Retrofit Angle	23.14
Operators, Sheaves & Limits	23.15
Reopening Devices	23.16
Controllers & Manuals	23.17

Installation Tools

Rail Tap Holder	23.18
Shoe Spreader/Adjuster	23.18
Rail Drilling Clamp Assembly	23.18
Hanger Hook	23.18
Door Dolly Assembly	23.18

Covers for Elevator Hoistway Junction Boxes

Part Number	Description	Size
031651	Cover for 031621	8 ³ / ₄ " x 10 ⁵ / ₈ " (222 x 270mm)
031652	Cover for 031622	6" x 7 ¹ / ₈ " (152 x 181mm)
031642	Cover for 03163 & 03164 & 031641	15" x 15" (381 x 381mm)
075149	Cover for 075148	12" x 12" (305 x 305mm)

Covers for Door Interlocks & Limits

Part Number	Description	Size
03598	Top cover for 2356-59 Interlock (0359)	3 ¹ / ₂ " x 5 ¹ / ₂ " (89 x 140mm)
03678	Top cover for 2356-67 Interlock (0367)	3 ¹ / ₂ " x 16" (89 x 406mm)
035568	Bottom cover for (Sub 035512) most interlocks	5" (127mm) long, bent 90°
0947555	Big cover for door limit	8" x 14 ¹ / ₂ " (203 x 368mm)
094753L/R	Small cover for 0947 door limit-reg	8" x 2 ¹ / ₂ " (203 x 64mm)
094754L/R	Small cover for 0947P door limit-pass	8" x 2 ¹ / ₂ " (203 x 64mm)
09347	Chain guard for door limit	6 ¹ / ₄ " x 6 ³ / ₈ " (159 x 168mm)

Covers for Gate Limits

Part Number	Description	Size
09352	Cover for 0935A Limit	11 ³ / ₁₆ " x 12 ¹ / ₈ " (284 x 308mm)

Compression Springs

Part Number	Description	Active Coils
033171	1/2" O.D. x 5/8" long (13 x 16mm) Used on Contact Bars	4
035510S	3/8" O.D. x 1 1/2" long (10 x 38mm) Used on Interlock Ratchet Arm-Sub 235510	12
035516	3/4" O.D. x 1 3/32" long (19 x 36mm) Used on Interlock Contact Arm	7
235510	3/8" O.D. x 1 3/4" long (10 x 44mm) Used on Interlock Ratchet Arm	12

Springs, Miscellaneous

Part Number	Wire Diameter	Used On
03457	0.125" (3mm)	Peelle Center Latch

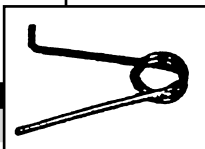

Parts by Category

Operators/Motors

Operator	Motor	Gear/Sheave
		Bearing Assembly
Door 0569	056910	05839
Door 0569M	056910M	05839
Door 0587	058720 058730	05839
Door 0594 E.R.	059421	05839
Door 0595 E.R.	059521	05839
Door, Manual	—	2593
Gate 2518	25182	25181
Gate 2517	25175	25181
Gate, Manual	—	2570 2571

Motor Pinions

Part Number	Description
05288	Door Motors – 4 Tooth
250723	Gate Motors – 8 Tooth

Bearings

Part Number	Description
05468	For motors and limits
05833	For operator gear/sheave assemblies

Rubber Bumpers

Part Number	Description
06113	Round, for gates
0611	Bumper Assembly for double section gates

Parts by Year: Landing Doors

Manual Landing Doors

	1950s	1960s	1970s	1980s	1990s	2000s
Guide Shoes	0238 (Reg) 0239 (Pass) (reversed after 1955)	0239 (Reg) 0238 (Pass)	0239 (Reg) 0238 (Pass)	0239 (Reg) 0238 (Pass)	0239 (Reg) 0238 (Pass)	0259 (Reg) 0258 (Pass)
Door Interlock Manual Door	0355-59 (sub 2356-59)	2356-59	2356-59	2356-59	2356-59	2356-59
Plugging Device	03561 (sub 23561)	23561	23561	23561	23561	23561
Side Tension	none (sub 06696)	0659 (sub 06696) 0660 (sub 06696) 06693 (sub 06696)	06696	06696	06696	06696
Door Astragal Flap	06585 (sub 06696, etc.)	06585	06585	06585	066053 Since 1995	066053
Manual Sheave	0527 (sub 2593)	0593 (sub 2593)	2593	2593	2593	2593
Door Chain	0166 (sub 01807)	0166 (sub 01807)	01807	01807	01807	01807
Door Chain Rods	0122 (sub 0121 with 01807, etc.)	0122 (sub 0121 with 01807, etc.)	0121	0121	0121	0121
Door Chain Rod Clips	0123	0123	0123	0123	0123	0123
Door Stops	0420	0420	0420	0420	0420	0420
Manual Door Unlocking Device	0393 (sub 2393 or 2398)	0393 (sub 2393 or 2398)	2393	2393	2393	2393/2378
Retiring Cam	0330 (sub 2330)	0330 (sub 2330)	2330	2330	2330	2330

Power Landing Doors

	1950s	1960s	1970s	1980s	1990s	2000s
Door Interlock Power Door	0355-67/0356-67 (sub 2356-67)	2356-67	2356-67	2356-67	2356-67	2356-67
Door Operator	0569	0569	0569	0569	0569	0569
Door Limit	0934 (sub 0947)	0934 (sub 0947)	0947	0947	0947	09682
Power Door Unlocking Device	0393 (sub 2395)	2395	2395	2395	2395	2395/2378N1

Parts by Year: Car Gates & Controls

Manual Car Gates

	1950s	1960s	1970s	1980s	1990s	2000s
Guide Shoes, Gate Panel	0233/0235 (sub 0255)	0239 (since 1958)	0239	0239	0239	0239
Guide Shoes, Counterweight	0232	0232	0232	0232	0232	0232
Gate Contact	2342	2343 (sub 2342)	2343 (sub 2342)	2343 (sub 2342)	2341 (sub 2342)	2342
Gate Astragal Flap	05207 (sub 2574)	05207 (sub 2570)	05207 (sub 2570)	2570	2570	2574
Gate Sheave Single	05207 (sub 2574 with 0179, etc.)	05207 (sub 2570) with 0179, etc.)	05207 (sub 2570) 2570	2570	2570	2574
Gate Sheave Double	2511 (sub 2571 with 0179, etc.)	2511 (sub 2571 with 0179, etc.)	2511 (sub 2570)	2571	2571	2571
Gate Chain	0166 (sub 0179, etc.)	0166 (sub 0179, etc.)	0179	0179	0179	0179
Two-Section Panel Sheave	0503 (sub 2582)	0503 (sub 2582)	0503 (sub 2582)	0503 (sub 2582)	2582	2582

Power Car Gates

	1950s	1960s	1970s	1980s	1990s	2000s
Gate Operator	two-speed 0549/0599/ 0573/0574/2517	0549/0599 or 2517	0599/2508/2507 or 2517	2517	2517	2517
Gate Limit	0935	0935	0935	0935	0935	09682
Reopening Device	0652 (sub new gate or 068412)	068412 (sub 46889)	068412 (sub 46889)	46899 Sensor Beam	4696 Light Curtain	46899 Sensor Beam 46969 Light Curtain

Controls

	1950s	1960s	1970s	1980s	1990s	2000s
Controllers	0751/075132 (sub 274200R)	075132 274200R	0765/2765 274200R	2767/2776 274200R	2776 274200R	2742
OT/CT 30-second timer	240V. 075117 (sub new 2776 controller)	240V. 075117 (sub new 2776 controller)	120V. 075138 (sub 274172 with 274175)	120V. 276708 (sub 274172 with 274175)	120V. 2767 (sub 274172 with 274175)	24VDC, 274251 CPU
TP 3-minute timer	240V. 0750 (sub 274200R controller)	240V. 0750/2760 (sub 274200R controller)	120V. 076223 (sub 274173 with 274175)	120V. 079066 (sub 274173 with 274175)	120V. 079066 (sub 274173 with 274175)	24VDC, 274251 CPU

Questions? Answers at...
(866) CED-ELEV • (866) 233-3538
www.cedlevator.com

Landing Door Guide Shoes

Guide Shoes

Door Type	1920s	1930s	1940s	1950-1955	1955-2000	2000-Present
Regular Door	0238	0238	0238	0238	0239	0258
Pass Upper Panel	0238	0238	0238	0238	0238	0258
Pass Lower Panel	029	029	029	0239	0239	0258
Large Doors Since 1993					0258	0258

Part Number	Dimensions	
	"A"	Bottom of base to guide
0239	1.312" (33mm)	1" (25mm)
Regular Door (8 Shoes) 1955-Present Pass lower Panel (4 Shoes) 1950-Present.		
0238B	0.937" (24mm)	0.62" (16mm)
Pass Upper Panel (4 Shoes) 1924-Present Regular Door (8 Shoes) 1924-1955.		
029	1.187" (30mm)	0.87" (22mm)
Pass Lower Panel (4 Shoes) 1924-1949 0.87" (22mm) from bottom of base to guide.		

Guide Shoe with Insert

0258	1.437" (37mm)	0.62" (16mm)
Large Doors (8 Shoes) 1993-Present.		

Guide Shoe Substitutions

Part Number	Description
025	Guide Shoe-Sub 0238B
026	Guide Shoe-Sub 029
027	Guide Shoe-Sub 0238B
028	Guide Shoe-Sub 0238B

Guide Shoe Grommet Nut

To Attach Guide Shoes: Use 5/16" x 5/8" Hex Head Cap Bolts with Flat Washer & Lockwasher. 065812 Shoe Grommet Nut (shown) must be used for the Shoe Bar Angle.

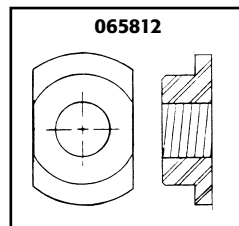

To Protect Shoes

Door Hold-Open Mechanical Device, Manual Doors

Door hold-open mechanical devices used to eliminate lower panel trucking sill rebound are optional retrofit upgrades for manual biparting freight doors on elevators carrying automobiles and trucks. Note: Power operated doors since 1950 are equipped with an electrical version of a hold-open device known as the automatic-stay-open feature.

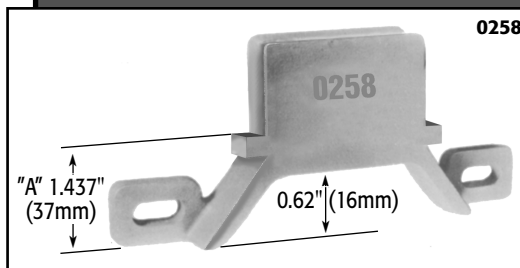
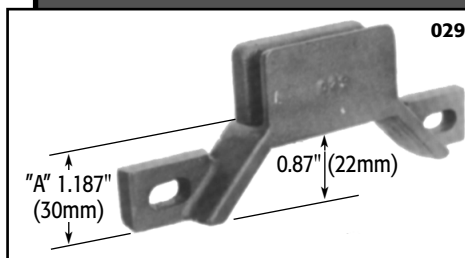
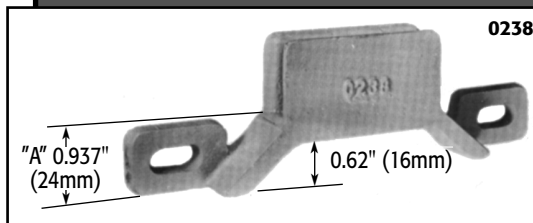
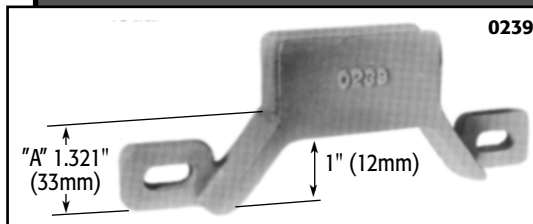
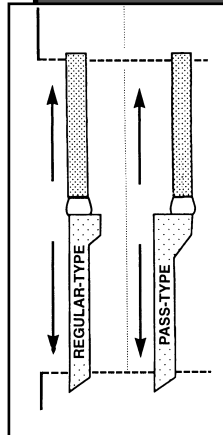

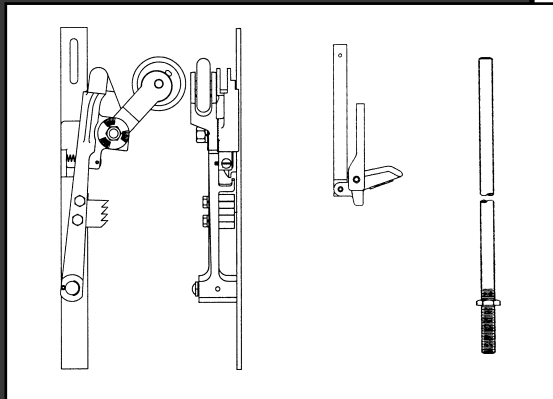
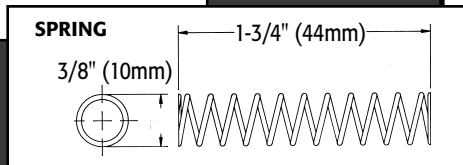
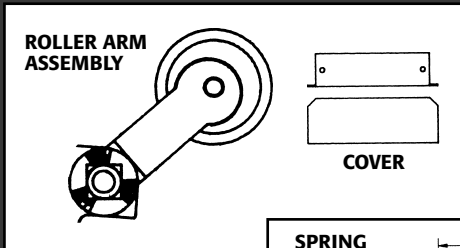
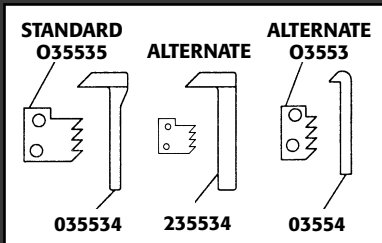

Landing Door Interlocks

Interlocks, Retiring Cam Required, 1930-Present

Power Door Manual Door

2356-67	2356-59	L/R Interlock NEMA 1/IP10
2332-29	2332-32	L/R Interlock NEMA 4/12/IP54/56
2344-29	2344-32	L/R Interlock NEMA 4X/IP56
23526	2352-53	L/R Interlock NEMA 7/9

Power Doors: 2 Contacts plus Zone Switch Assembly.
Manual Doors: 2 Contacts. Specify left or right hand.

Interlock Components

Part Number Description

235510	Spring
035512	Cover
035562	Roller Arm Assembly

Extension roller arm assemblies available.

Interlock-Related

Part Number Description

23651	Contact Plugging Device
235615	Plug Rod 4'6" (1370mm) standard length and cut to suit in field, unless dimension is given Note: Interlock plugging prevents door-closed contact from being made when door is open. Retrofit work is required to add plugging device onto landing doors prior to 1955.
0354	L/R Side-Opposite-Lock (No Contact) Retiring or fixed cam required. On doors over 10ft. (3000mm) wide. Available in narrow version 2354. Specify left or right hand.
2354	L/R Side-Opposite-Lock (No Contact) Narrow Version of 0354 Retiring or fixed cam required. On doors over 10ft. (3000mm) wide. Specify left or right hand.

Unlocking Devices & Components

Part Number	Description	Key
2380	Manual Doors	03932 (AUES)
2380N1	Motorized Doors	03932 (AUES)
2380N4	Nema 4 Motorized Doors	03932 (AUES)

Unlocking Device-Related

Part Number	Description
2392	Key Holder, Surface Box

Interlock Keepers

Ratchets

Part Number	Description
035535	
03553	Tight Space

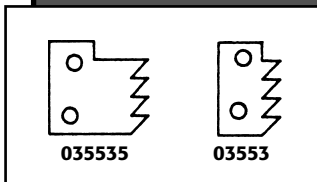

Lower Panel Keeper Hooks

Part Number	Description
035534	
235534	Large Doors
03554	Tight Space

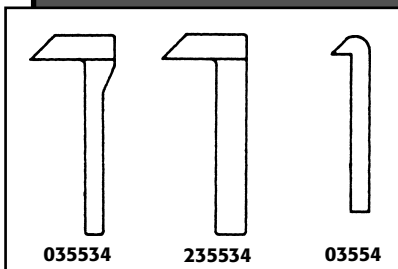

Upper Panel Keepers

Part Number	Description
066975	Regular-Type Door
066976	Pass-Type Door

Specify left or right hand. Left hand as shown.
Right hand opposite to shown.

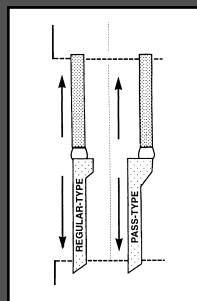
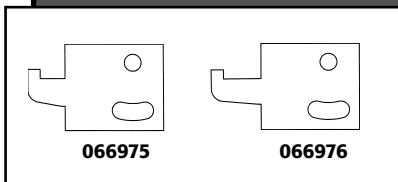

Note:

Upper Panel Locks need to be added for interlocks/doors manufactured prior to 1977. New interlock required. Refer to *Peelle Modernization Manual 205*, Illustrations 23 and 24. New guide shoes are recommended at the same time.

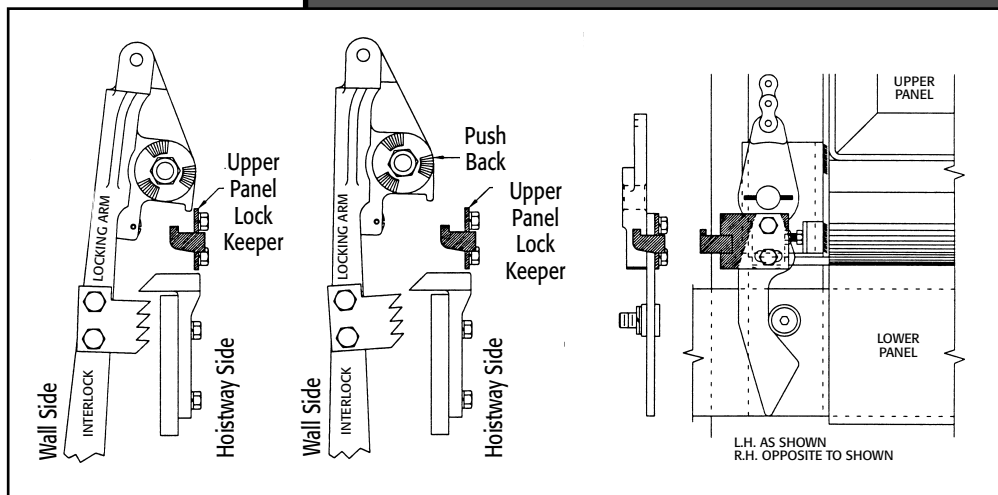

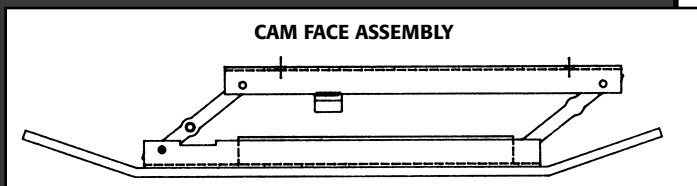
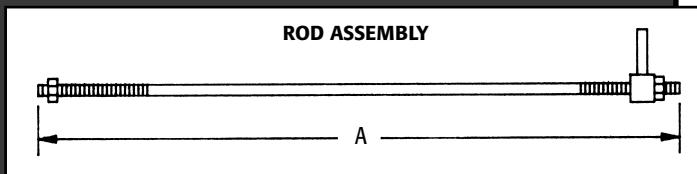
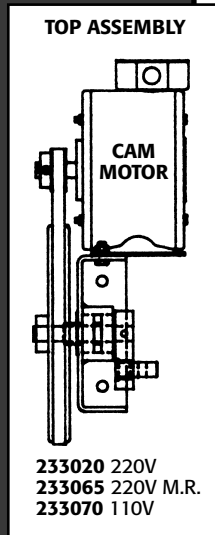
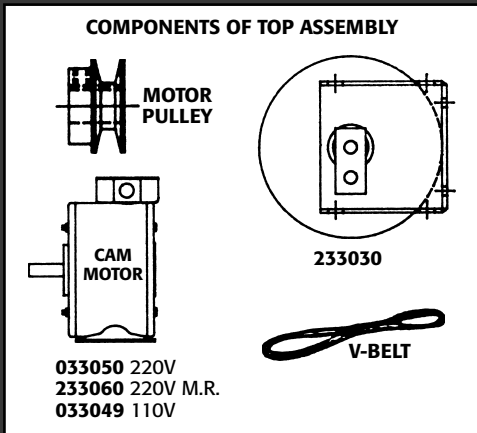
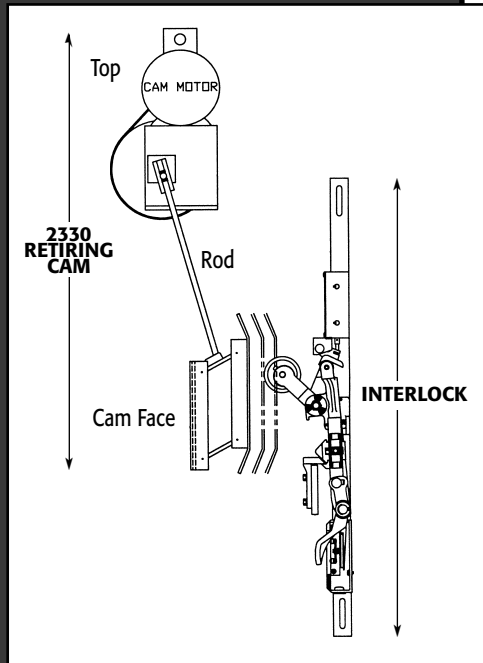

Landing Door Retiring Cams

Retiring Cams

Part Number	Description
2330	1975–Present Retiring Cam
0330	1950–1975 Retiring Cam–Sub #2330
0377	1935–1950 Retiring Cam–Sub #2330

- Used to operate landing door interlocks.
- Mounted on car gate/car door.
- Used with (1) 033064 and (1) 033065 bracket for power car gates, or a mounting angle for manual car gates.
- Made up of three assemblies (top, rod, and cam face) (see illustration).
- Hand is determined standing on car facing door.

Top Assembly & Components

Part No.	Description
233020	Top Assembly NEMA 1/IP 10, 220V
233065	Top Assembly NEMA 4/IP54, 220V
233070	Top Assembly NEMA 1/IP10, 110V
033021	V-Belt
033027	Motor Pulley
033050	Cam Motor NEMA 1/IP10, 220V
233060	Cam Motor NEMA 4/12/IP54, 220V
033049	Cam Motor NEMA 1/IP10, 110V
233030	Reduction Unit NEMA 1/IP10
233025	Reduction Unit NEMA 4/IP54

Top assembly parts are universal in hand. Hand is determined when assembled. Top assembly is 15.5" high, 9.5" deep, 7" wide (390mm high, 240mm deep, 180mm wide).

Rod Assembly

Part No.	Description
97179	Connection Rod, "A" Length

Offered in different lengths to suit different door heights. Give Peelle job number or "A" length.

Cam Face Assembly

Part No.	Description
233010	Cam Face Assembly

Cam face is 36" high, 4.75" deep, 2" wide (910mm high, 120mm deep, 50mm wide)

Questions? Answers at...
(866) CED-ELEV • (866) 233-3538
www.cedlevator.com

Landing Door Chains & Panel Parts

Door Chains

1968–Present

Part No.	Description
01807	Door Chain (need length)
01801	Connecting Link (order separately)

1936–1968

Part No.	Description
0166	Door Chain-Sub #01807

Note: Peelle #01807SS Stainless Steel Chain is available. Peelle #01806 Chain Assembly is 01807 chain and (2) 01801 Connecting Links.

Chain Rod

1968–Present

Part No.	Description
0121	Chain Rod, 0.5" (13mm) Square, 42" (1070mm) long, 4" (100mm) thread length

Rod Clip

1936–Present

Part No.	Description
0123	Rod Clip, lower panel, for 0.5" (13mm) square rod

Tension Latch & Components

1968–Present

Part No.	Description
06696	L/R Tension Latch Assembly
06592	Roller Keeper

Parts are universal in hand. Hand is determined when assembled. R.H. as shown. L.H. opposite to shown.

Sill Stop Assembly & Components

1950–Present

Part No.	Description
0420	Sill Stop Assembly
04202	Adjustable Stop Piece
04203	Adjustable Stop Angle
04204	Sill Stop Assembly

See Peelle Modernization Guide 312 for the following replacements:

- Door Panels – Section 2
- Door Rails – Section 3
- Door Astragals – Section 4

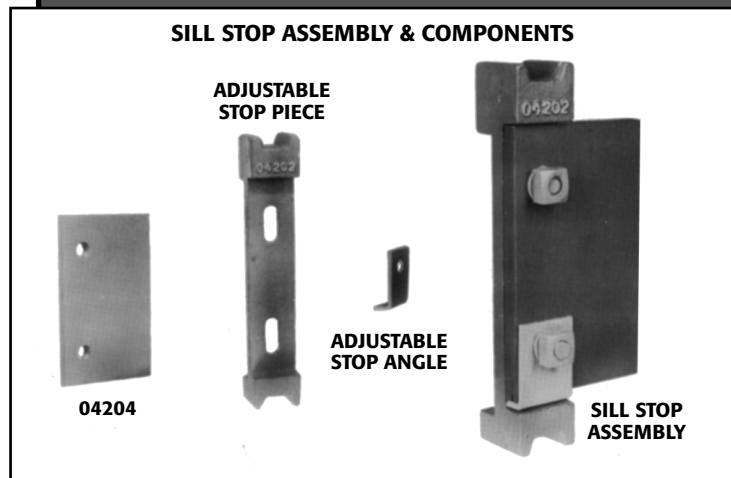
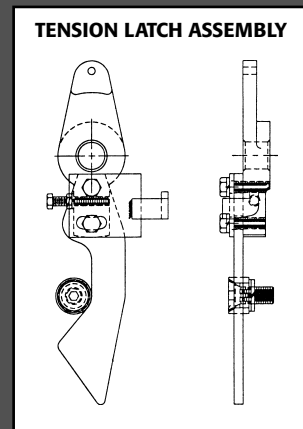
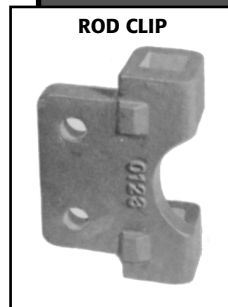
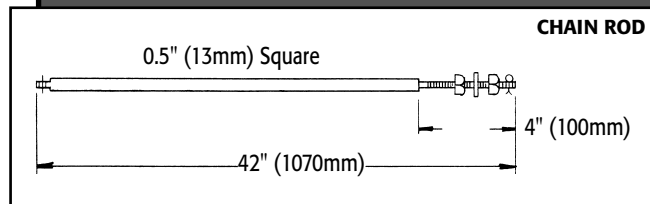
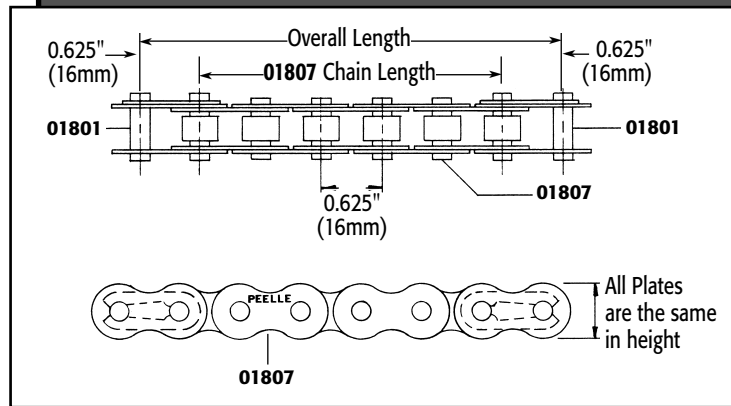

Landing Door Operators & Components

Power Door Operators 1950–Present

Operator Number	Motor Number	Description	Door Width
0560 L/R	056921	Standard Torque NEMA 1/IP10	Less than 10' x 10' (3000 x 3000mm)
0569 L/R	056910	High Torque NEMA 1/IP10	10' x 10' (3000 x 3000mm) and larger
0560M L/R	056921M	Standard Torque NEMA 4X/IP56	Less than 10' x 10' (3000 x 3000mm)
0569M L/R	056910M	High Torque NEMA 4X/IP56	10' x 10' (3000 x 3000mm) and larger
0595 L/R	059521	High Torque NEMA 7/9	10' x 10' (3000 x 3000mm) and larger
2569 L/R	256910	Extra High Torque	15' x 15' (4500 x 4500mm) and larger
0587 L/R	058720	High Speed Motor	Narrow width operator
	058730	Slow Speed Motor	Narrow width operator

Note: Motors are 220V, 3 Phase, 50/60 Hertz, Two-Speed. Parts are universal in hand. Hand is determined when assembled.

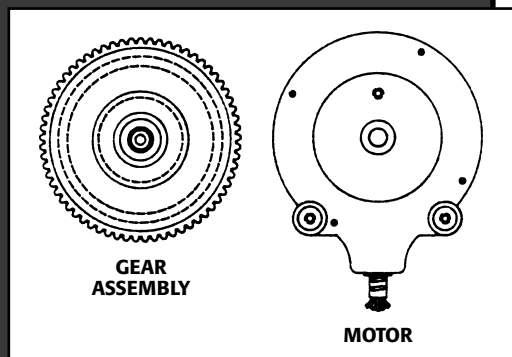
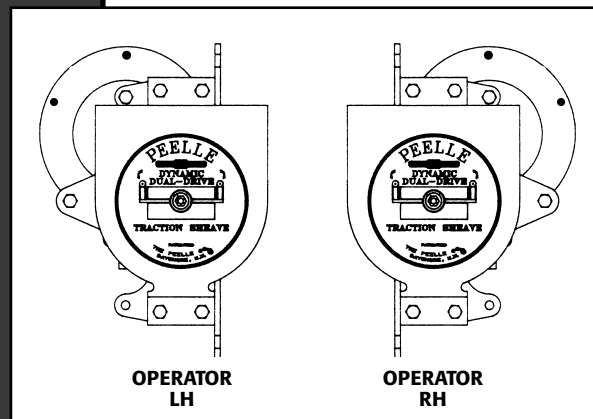
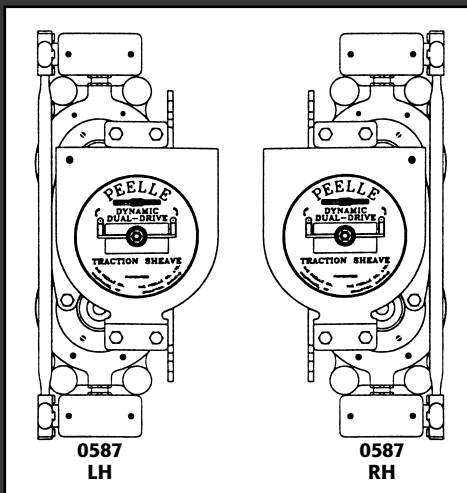

Operator Components

Part Number	Description
05839	Gear/Sheave/Bearing Assembly
05696	Bearing Shaft Bolt with Grease Fitting
05288	4 Tooth Spiral Pinion (included with motor)

To power operate or re-motorize existing freight elevator doors manufactured by Peelle or other, see *Peelle Modernization Guide 312*, Section 1. Peelle power doors manufactured prior to 1950 should be upgraded with Peelle power conversion package.

Landing Door Sheaves & Limits

Manual Door Sheave 1950–Present

Part Number	Description
2593	Manual Door Sheave Assembly

Door Limits 1950–Present

Part Number	Description
0947L	Door Limit Assembly, LH, opposite as shown, Regular Door
0947R	Door Limit Assembly, RH, shown, Regular Door
0947L PASS	Door Limit Assembly, LH, for Pass-type Door
0947R PASS	Door Limit Assembly, RH, for Pass-type Door
0955 L/R	Door Limit Assembly, NEMA 4/12/IP54/56
0956 L/R	Door Limit Assembly, NEMA 4X/IP56
094931	Door Limit Switch, NEMA 7/9

Hand determined standing on car facing door.

Note: 1950–1968 Limits require change to Peelle #01807 roller chain when changing complete limit assembly.

Limit Components

Part Number	Description
093415	Cam Carrier and Switches Assembly–Regular Door
09478	Cam Carrier and Switches Assembly–Pass Door
093451	Sprocket
093444	Micro-Switch, Typical Marking BZ–2RW822T
093445	Micro-Switch, Typical Marking BZ–3YWT822

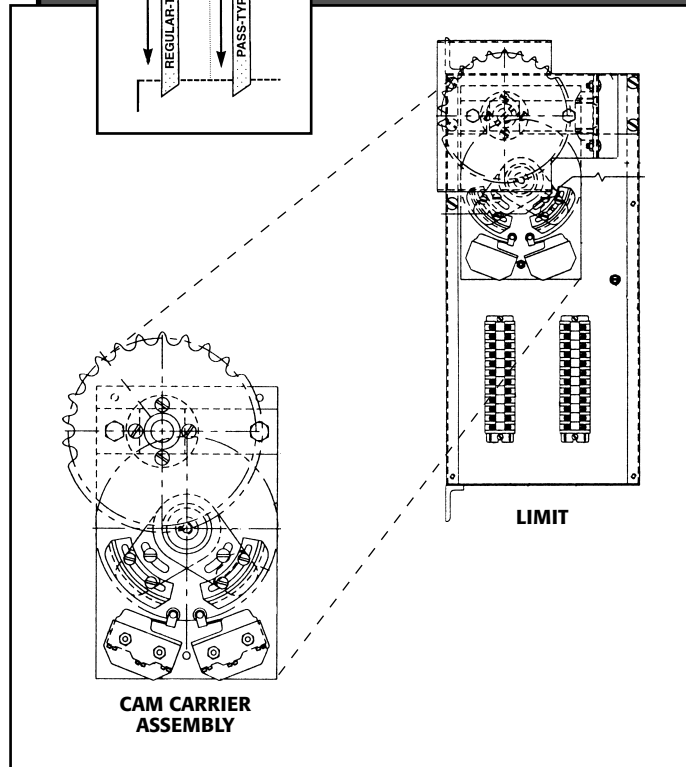
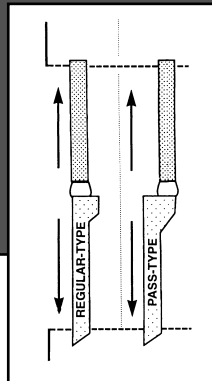
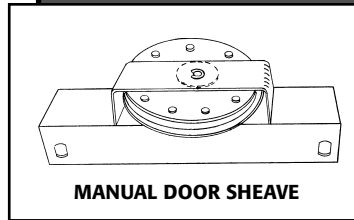

0560 & 0569 DOOR OPERATORS

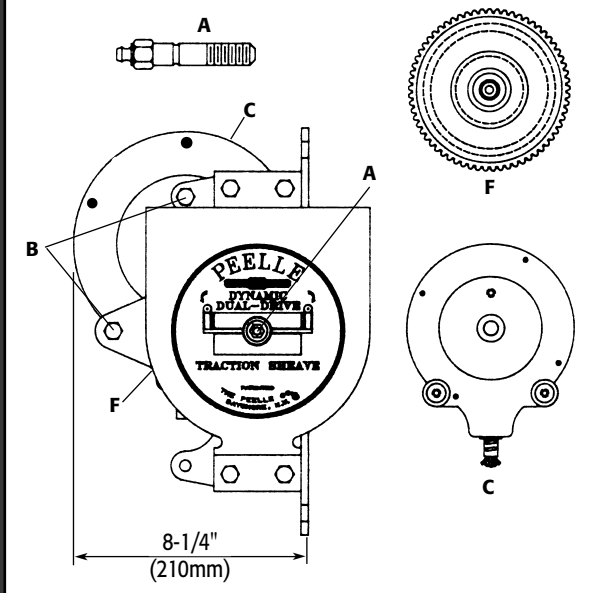
8-1/4"
(210mm)

0587 DOOR OPERATOR

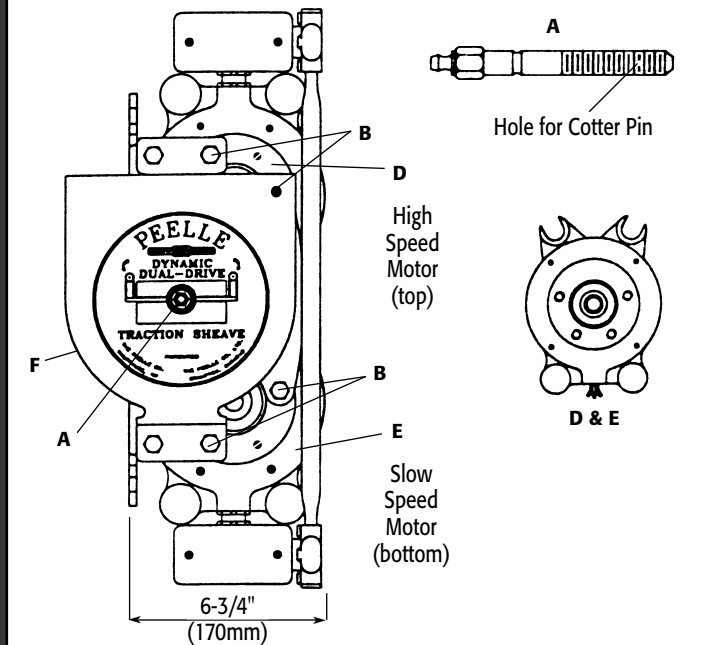
6-3/4"
(170mm)

Landing Door Operator Motor Replacement

Each door employs (2) two dual-speed power door operators. 0560 and 0569 uses one motor with a 2-speed winding (high and slow speed); 0587 uses two individual motors, one high, one slow speed.

- A. Door operator bearing bolt
- B. Motor mounting bolts
- C. Door motor for 0560 and 0569 standard operators
- D. 900 rpm door motor for 0587 narrow return operators
- E. 450 rpm door motor for 0587 narrow return operators
- F. Door operator gear/sheave/bearing assembly

To Replace Motor

Part Number **0560** and **0569** Door Operator (shown at left)

1. Remove bolts (B).
2. Loosen sheave bearing bolt (A) enough to clear thread on motor.
3. Disconnect motor leads.
4. Remove motor.
5. Install new motor.
6. Replace bolts (B).
7. Tighten bearing bolt (A).
8. Reconnect wires. Make sure motor rotates in proper direction. Motor has 5 wires identified by label.

Part Number **0587** Door Operator (shown at left)

1. Remove bolts (B).
2. Loosen sheave bearing bolt (A) 1/8" (3mm).
3. Open boxes and disconnect motor leads.
4. Loosen lock nut, allowing box to be removed from nipple.
5. Remove nipple from motor housing and mount onto new motor.
6. Remove motor (D) upward and motor (E) downward.
7. Install new motor (D) diagonally downward and (E) upward. Make sure that the slotted lug is bottomed on the sheave bearing bolt (A)! This ensures proper gear setting and alignment.
8. Replace bolts (B) on both motors. Tighten bearing bolt (A) carefully and firmly.
9. Reconnect conduit and wires. Make sure motor rotates in proper direction for each speed. Red wires are high speed. Black wires are slow speed. Each motor has three wires; one wire of each motor is the common wire.

Questions? Answers at...

(866) CED-ELEV • (866) 233-3538
www.cedlevator.com

Car Gate/Car Door Shoes & Contacts

Car Gate Panel (4 Shoes)

1958–Present

Part No.	Description	"A" Dimension
0239	Guide Shoe	1.312" (33mm)

1935–1958

Part No.	Description	"A" Dimension
0233/0235	Roller Shoe–Sub 0255	2.5" (64mm)

Prior to 1935

Part Number	Description	"A" Dimension
027	Guide Shoe–Sub 0238	0.937" (24mm)

To attach Guide Shoes, use (2) 5/16" x 5/8" Hex Head Cap Bolts with Flat Washer and Lockwasher.

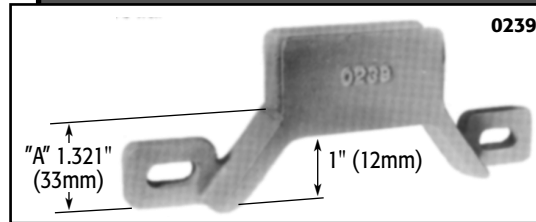

Car Gate Counterweight (2 Shoes)

1935–Present

Part Number	Description
0232	Counterweight Shoe

To attach 0232 shoe, use (2) Peelle #02325 bolts with thread-locker, no lock washer, no flat washer.

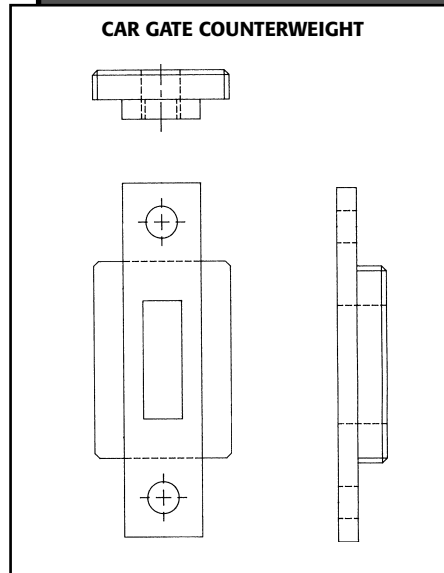

Gate Contacts

1955–Present

Part Number	Description
2341	Gate Contact

Used with vertically sliding manual or power operated car gate as the electric contact. NEMA 1/IP10. The individual parts of the Peelle #2341 contact are universal in hand; reversing the covers will determine left or right hand assembly.

Part Number	Description
234316	Cam. Universal in hand.

Used with but not part of Peelle #2341 Gate Contact. Must order separately.

1930–1954

Part Number	Description
0341/0342	Gate Contact–Sub #0342 Gate Contact

Note: Gates prior to 1960: Move car gate contact out of the reach of persons inside the car with Peelle Kit #23436 (not shown).

Note: Peelle #2368 (not shown) is used as a car gate/car door restraint device when car is away from floor.

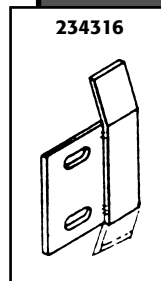
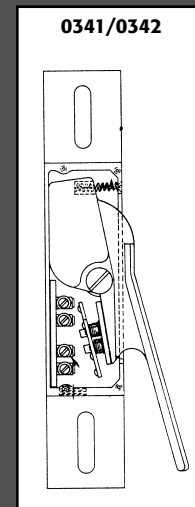
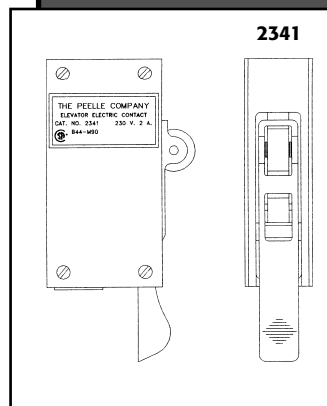

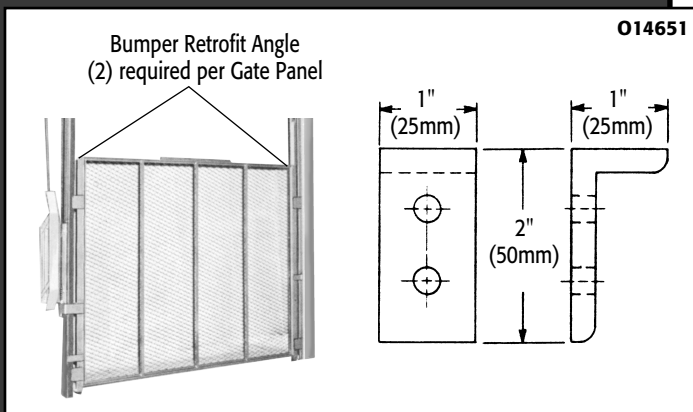
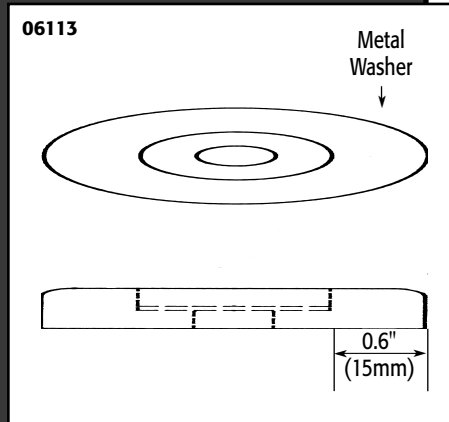
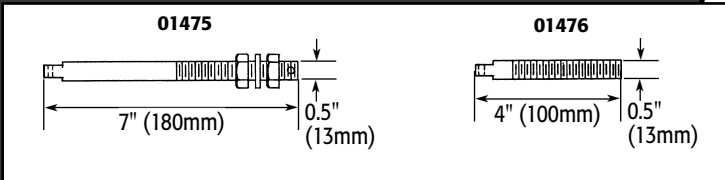
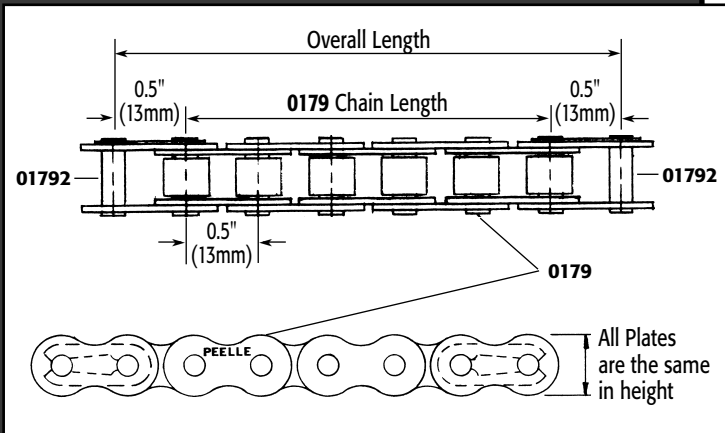

Car Gate Chains & Panel Parts

Gate Chains

1968-Present

Part Number	Description
0179	Roller Chain (need length)
01792	Connecting Links (order separately)

1930-1968

Part Number	Description
0165	Chain-Sub #0179
0166	Chain-Sub #0179

Note: Peelle #0179SS Stainless Steel Chain is available. Peelle #01794 Chain Assembly is 0179 chain and (2) 01792 Connecting Links.

Chain Studs

1968-Present

Part Number	Description
01475	Chain Stud for Panel
01476	Chain Stud for Counterweight
01468	Two Section Gate Chain Stud (not shown)

Bumpers

1968-Present

Part Number	Description
06113	Bumper (2) Required on Bottom of Car Gate Panel.

Bumper Retrofit Angle

1960-1980

Part Number	Description
014651	Bumper Retrofit Angle

Bumper Retrofit Angle (2) required per Gate Panel to extend life of Peelle #063 Bumper. Mount on top of gate panel. Replace Peelle (2) #063 Bumpers on gate rails at same time.

Car Gate Panel Replacements – See *Peelle Modernization Guide* 312 Section 8

Car Gate Rails Replacements – See *Peelle Modernization Guide* 312 Section 9

Car Gate Operators, Sheaves & Limits

Power Gate Operators 1950-Present

Operator Number	Motor Number	Description	Door Width
2518	25182	Standard Torque	Less than 10' (3000mm)
2517	25172	High Torque	10' and over
2548	25482	Standard Torque NEMA 4/12/IP54/56	Less than 10'
2547	25472	High Torque NEMA 4/12/IP54/56	10' and over
2548M	25482M	Standard Torque NEMA 4X/IP56	Less than 10'
2547M	25472M	High Torque NEMA 4X/IP56	10' and over
2528	25282	Standard Torque NEMA 7/9	Less than 10'
2527	25272	Standard Torque NEMA 7/9	10' and over

Note: Motors are 220V, 3 Phase, 50/60 Hertz, 2-Speed. Parts are universal in hand. Hand is determined when assembled.

Operator Components

Part Number	Description
25181	Operator without motor, includes mounting, gear, bearing, grease fitting.
250723	8-Tooth Spiral Pinion
250725	Pinion Bolt

Manual Gate Sprockets 1950-Present

Part Number	Description
2570	Manual Assembly-Single Sprocket
2571	Manual Assembly-Double Sprocket
250722	Sprocket with Bearing-for 2570 or 2571

Gate Limits 1950-Present

Part Number	Description
0935L	Gate Limit Assembly, Left hand, opposite as shown
0935R	Gate Limit Assembly, Right hand, shown
0960 L/R	Limit Assembly, NEMA 4/12/IP54/56
0961 L/R	Limit Assembly, NEMA 4X/IP56
0949 L/R	Limit Assembly, NEMA 7/9

Hand determined standing on car facing door.

Limit Components

Part Number	Description
093520	Cam Carrier and Switch Assembly
09350	Sprocket and Plates Assembly (inc. Peelle 093527, 09353, 09356, 05468)
093444	Micro-Switch, Typical Marking BZ-2RW822T
093445	Micro-Switch, Typical Marking BZ-3YWT822

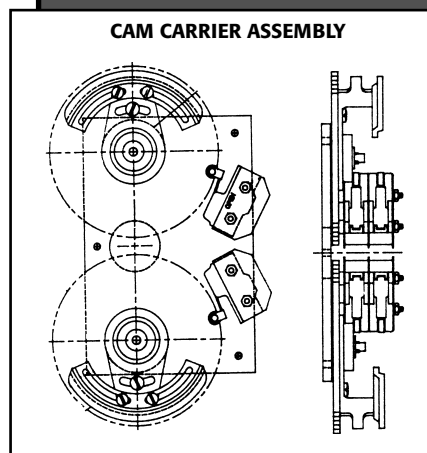
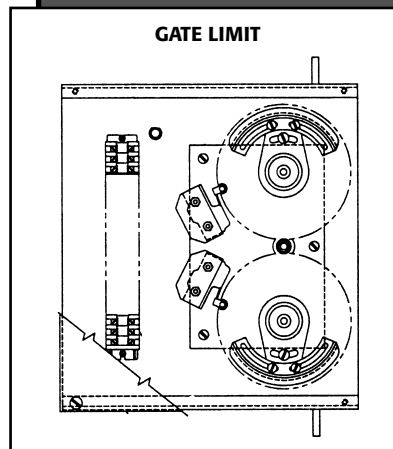
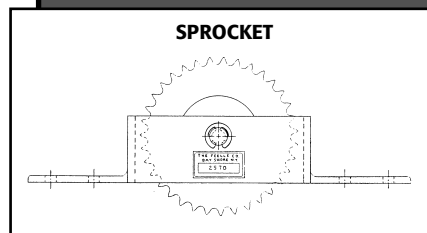
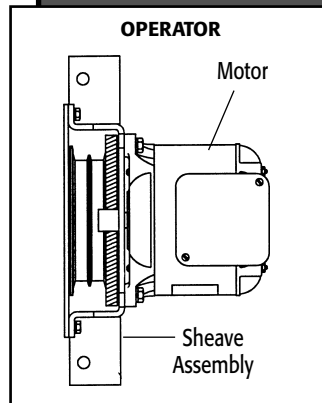

Questions? Answers at...
 (866) CED-ELEV • (866) 233-3538
www.cedlevator.com

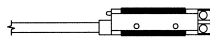
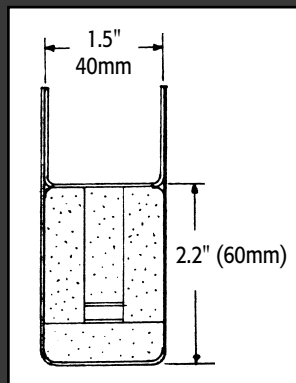
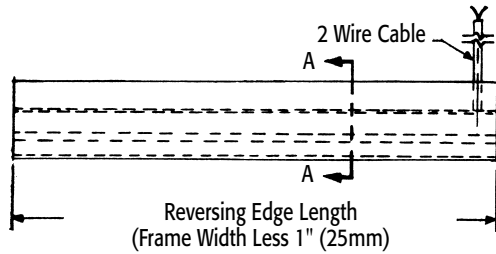
**068412 REVERSING EDGE
FOR SINGLE-SECTION CAR GATES**

468508 SOURCE

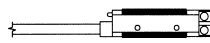

468508 DETECTOR

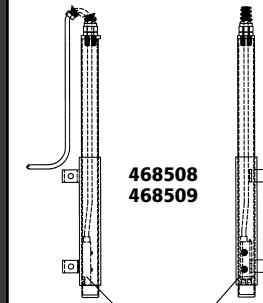
468508
468509

Reopening Devices

Reversing Edge, Contact Type

(Give length or job number)

1962 to Present

Part Number	Description
068412	Reversing Edge, NEMA 1/IP10 (give length)
469501	Reversing Edge, NEMA 7/9, Pneumatic (give length)

Reversing Edge-Related (order separately)

Part Number	Description
068442	3-Wire Travel Power Cord (used with 068412)(give length)

Reversing Beam, Non-Contact Type

Part No.	Description
46899	Sensor Beam Replacement Kit (moisture resistant)
468508 & 468509	Source & Detector, for Reversing Beams. (sold together)

Components

Part Number	Description
468508	Sensor Beam Source, LH Side-Order as 46889 Kit Less Transformer and Relay
468509	Sensor Beam Detector, RH Side-Order as 46889 Kit Less Transformer and Relay

Hand determined standing on car facing door.

Related (order separately)

Part Number	Description
068440	4-Wire Travel Power Cord (used with Sensor Beam)(give length)

To add reopening device to Peelle car gates 1962 to present
See *Peelle Modernization Guide 312* Section 10 and use 46889 Kit.

To change Simultaneous Operation to Sequence Operation
See *Peelle Modernization Guide 321* Section 11

Controller Components

[110/220 Volts, 3 Phase, 50/60 Hertz]

1950 to Present

Part Number	Description
075155	Fuse, 10 Ampere
076200	Transformer 220/120-15V
076202	Fuse, 1.5 Ampere
076203	Fuse, 0.25 Ampere
07623	Relay
076245	Relay
076255	Relay (12V)
076262	Relay
07628	Contactors
076287	Coil
076289	Micro Switch
079061	Relay
079064	Relay
079066	Timer, 3 Minute, TP
079402	Timer, 0.4-4 Seconds
275510	Relay
276705	Timer, 25-256 Seconds
276706	Timer, 3-32 Seconds
276708	Timer, 30 Seconds, OT/CT
277607	Trans 220/120-24V
277608	Fuse, 2 Ampere

Controllers manufactured prior to 1969 should be upgraded with new, replacement controllers to reduce motor burnouts. The cost of a new controller is less than several motor replacements.

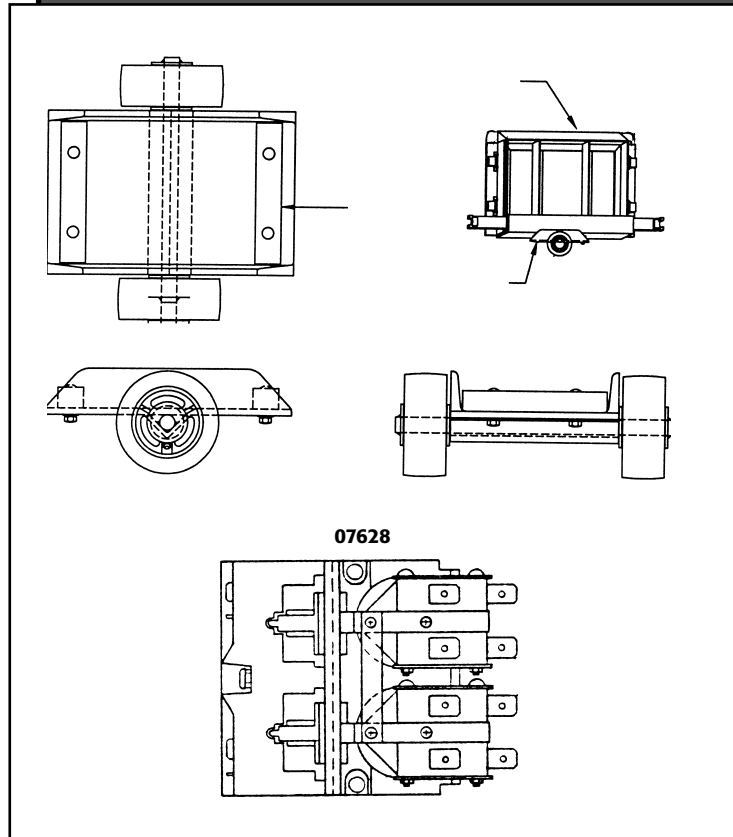

Controller Manuals [Peelle No. 201]

Job Date	Controller Series	Manual Date	Relay Voltage
1930-1948	-	1938	220
1948-1950	-	1950	220
1951-1953	0751	1953	220
1953-1956	075132	1954	220
1966-1969	0759	use 1954	220
1969-1969	0762	1969	110V
1969-1974	0765 (sockets)	1972	110V
1974-1979	2765 (plug-in timers)	1974 revised 1979	110V
1979-1986	2767 (Fire Service included)	1974 revised 1979	110V
1986-1994	2776 (no push-button back contacts)	1989	110V
1995-1999	2776 (may have sensor beam)	1989 revised 1998	110V
2000-Present	2741 (miniature relays)	1989 revised 1998	110V
2002-Present	2742 (PLC) (no service tool required)		

Controller Maintenance

See Peelle Maintenance Manual 204, section 18.

Controller Replacement or Modification

See Peelle Modernization Guide 312, section 11.

Questions? Answers at...
 (866) CED-ELEV • (866) 233-3538
www.cedlevator.com

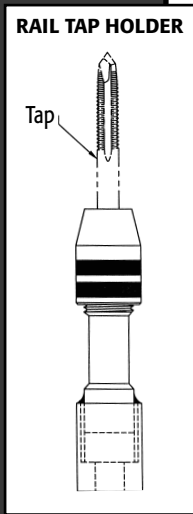
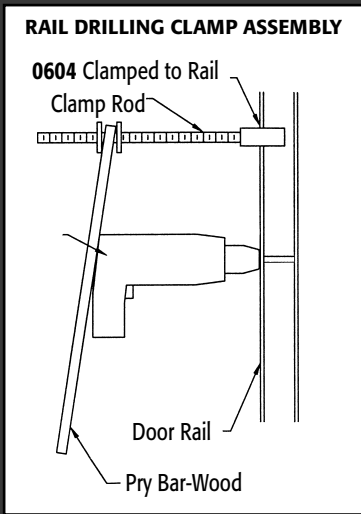

Installation Tools

Rail Drilling Clamp Assembly
Part Number **0604**

Rail Tap Holder
Part Number **0602**
Rail Tap Holder for impact tool

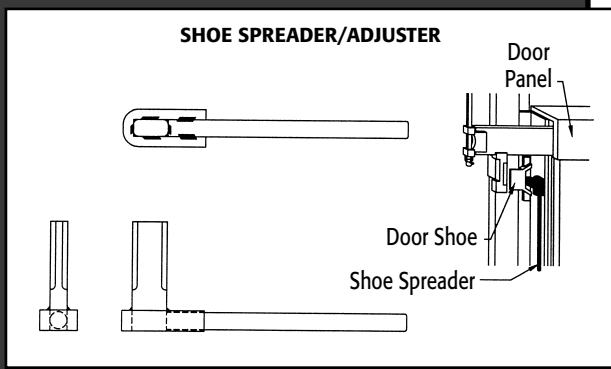

Shoe Spreader/Adjuster
Part Number **0603**
Shoe Spreader/Adjuster for Peelle Shoes
1930 to Present

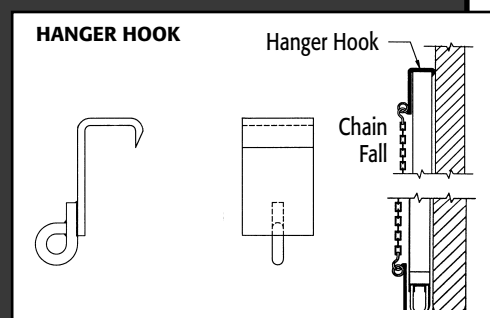

Hanger Hook
Part Number **0605**
Hanger Hook for hanging Chain Fall from top of door and for hoisting Upper Door Panel

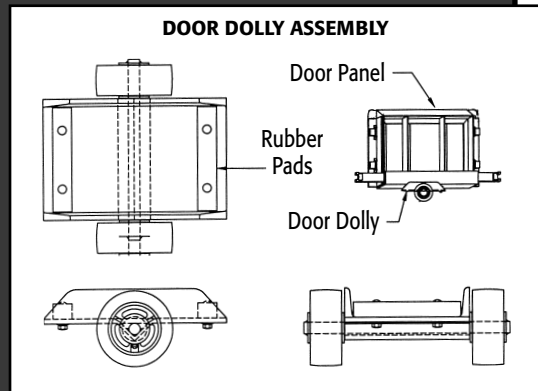

Door Dolly Assembly
Part Number **0606**
Door Dolly Assembly for Biparting Doors
and Car Gates with Crating

Questions? Answers at...
(866) CED-ELEV • (866) 233-3538
www.cedlevator.com

RAIL INSTALLATION & ALIGNMENT

24

In This Section

Plumb Line Clamps	24.2
Laser Alignment System	24.2
Plumb Line Tensioner	24.3
Piano Wire	24.3
Plumb Line Gauges	24.3
Adjustable Flexible File Holder	24.4
Rail File	24.4
File Handle	24.4
Rail Gauge	24.4
Rail Shims	24.4
Rail Oilers	24.4
Rail Brackets, Extensions & Clips	24.5
Rail Inserts	24.5
Wall Inserts	24.5

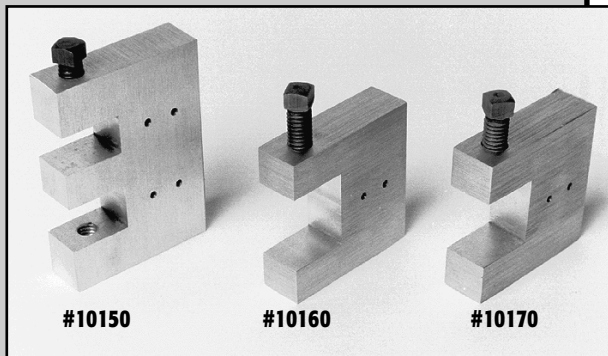

Plumb Line Clamps

Plumb Line Clamps

These clamps have been designed to accurately secure the plumb line 1/2" or 1" from the center of the rail face. They are made of high-strength, lightweight aluminum. The combination plumb line clamp has been designed for 5/8" and 3/4" rail faces.

Part Number	Size
10150	5/8" & 3/4"
10160	1 1/8"
10170	1 1/4"

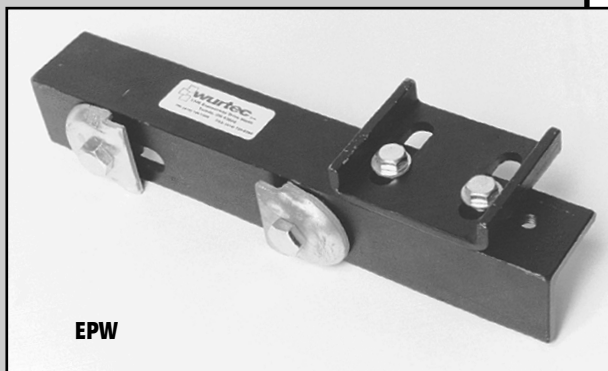

Adjustable Plumb Line Clamp

This adjustable plumb line clamp works ideally with the realignment pointer set (#10-110), by allowing you to drop your plumb line to the side of the rail. This provides you with an accurate reference in the hoistway, adjacent to the rail and without interference from the car.

Part Number **10180**



Intermediate Plumb Line Clamp

Don't let wind or solar loads affect your extra long plumb lines. Simply install these intermediate clamps where needed to control your lines. Loosen the screw, slip the line into the proper hole, tighten and mount to aligned rail. You are now ready to continue aligning between clamps.

Part Number **10151** (5/8" & 3/4")



Laser Alignment System

This Laser Alignment System can be used to realign the rails in a hoistway or to align them for the first time. It is also great for surveying the hoistway in preparation for installing your equipment.

Part Number **10114**

Questions? Answers at...
 (866) CED-ELEV • (866) 233-3538
www.cedlevator.com

Plumb Line Tensioner & Gauges, Piano Wire

Plumb Line Tensioner

Easily maintains tension in plumb line up to its ultimate breaking strength. Lightweight, compact, easy to install over our plumb line "clamp" (#10-150, 160 & 170)... Re-tensions in seconds, if required. Pays for itself by the end of first job. Plated finish for longer life against the elements.

Part Number **10190**

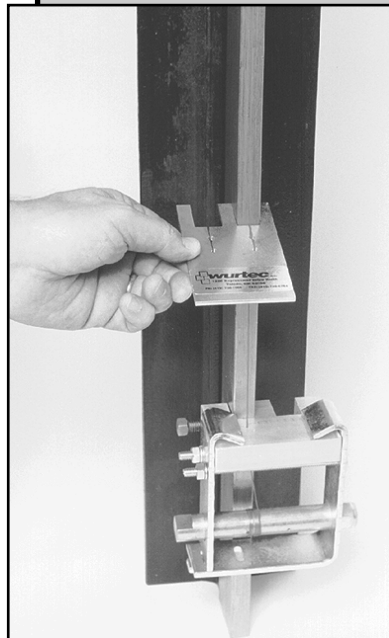

Piano Wire

This important part of the rail alignment system is available in one and three pound packages. There are approximately 440 feet of wire per pound. The diameter of wire is 0.029" and the ultimate breaking strength is 200 pounds.

Product	Description
PIANO WIRE 1LB	.29 1LB SPOOL
PIANO WIRE 3LB	.29 3LB SPOOL
PIANO WIRE 5LB	.29 5LB SPOOL

NOTE: Other diameters, lengths and types of wires are available upon request.

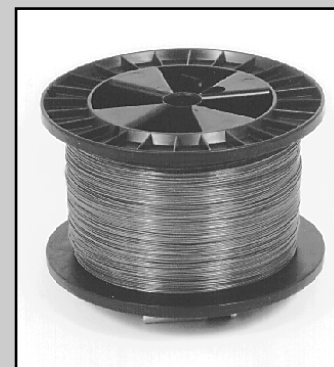

Plumb Line Gauges

These gauges have been designed to readily indicate the rail placement and alignment relative to a plumb line located from our clamps. They are made of 1/8" steel and plated for protection against the elements. The combination gauges are made for 5/8" and 3/4" rail faces. The slots are either adjacent (#10-200) or located front to rear (#10-210), for your convenience.

Part Number	Description
10200	5/8" & 3/4" Combo
10210	5/8" & 3/4" Combo Front/Rear
10211	5/8" & 3/4" Combo Front/Rear & False Car
10220	1 1/8"
10230	1 1/4"

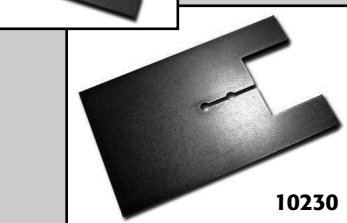
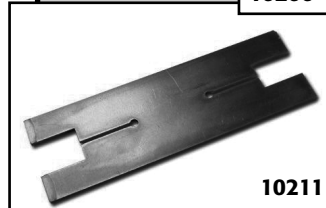
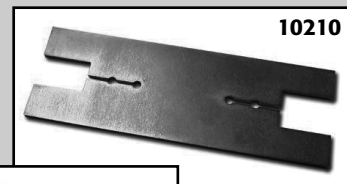
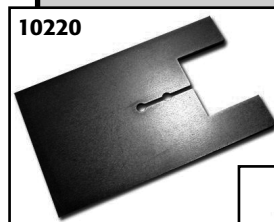

Questions? Answers at...
 (866) CED-ELEV • (866) 233-3538
www.cedelevator.com

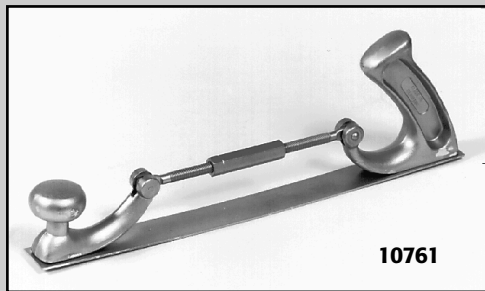

10761

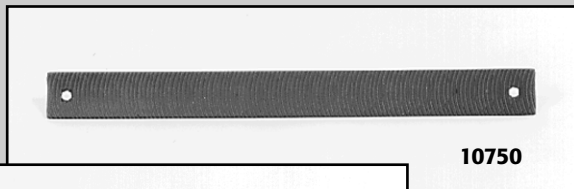

10750



10760



10125

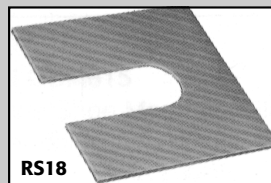

RS18

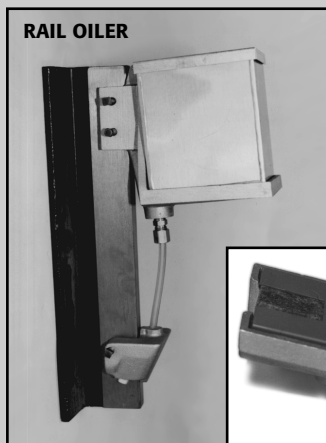

RAIL OILER

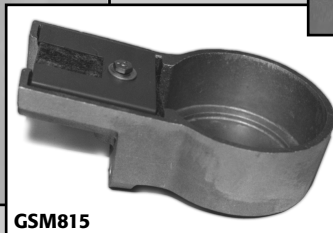

GSM815

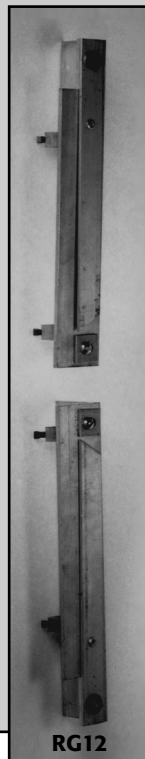

RG12

Rail Files & Holders

Rail Gauge, Shims & Oilers

Adjustable Flexible File Holder

Can easily be adjusted for curving the file either outward or inward, and used with 12 or 14" files.
Part Number **10761**

Rail File

Made from the finest, hardened steel available. When used in combination with our handle, this file is a fine tool for dressing guide rail joints and step wheel tracks on escalators, for quieter and smoother rides.
Part Number **10750**

File Handle

Made of smoothly shaped wood that fits comfortably in the hand. Works great in combination with steel Rail File (above).
Part Number **10760**

Rail Gauge

Assures smooth elevator operation by properly aligning rails. Use them to set guide rails facing square and for correct D.B.G.

- Quickly attaches to 1/2" or 3/4" conduit with the set screws provided in the gauge fastening bracket.
- Accurately fabricated in aluminum to provide a precision tool.

Part Number **RG12**

Universal Rail Shim

0.015 (1/64" x 2 1/2" x 7"). Slotted for ease of installation. Fits bolt patterns from 3 1/2" to 5 1/4" centers without bolt removal. Shim will not fall out if hardware loosens.
Part Number **10125** (package of 200)

Single Slot Rail Shim

Easily added after rail is in place.
3" x 3" with 1 3/16" x 2" slot.

Part Number	Description
RS18	1/8" thick, 25 per pack
RS37	1/32" thick, 100-piece bundle
RS538	1/16" thick, 50-piece bundle

Rail Oilers

With wick and copper tubing, a controlled flow of oil moves slowly and easily down the rail, oiling and cleaning continuously.

Part Number	Description
RM815	For 8, 12, and 15 lb. guide rails
RM2230	For 22.5, and 30 lb. guide rails
GSM815	Mounts to guide shoes, set of 2

Questions? Answers at...
(866) CED-ELEV • (866) 233-3538
www.cedlevator.com

Rail Brackets, Extensions & Clips

Rail Brackets

This adjustable rail bracket is made of 1/4" carbon steel. Our standard bracket adjusts from 2 1/4" to 8". For depths greater than 8" we will custom design. Fits 8, 12 and 15 lb. Rails.

Rail Brackets, Extensions & Clips

Adjustable 7-gauge carbon steel bracket fits 8, 12, 15 lb. rails. Bracket to wall. Bolts by others.

Part Number	Description
ARB825	2 7/16" to 10 1/2" adjustment
ARB825E	Extension plate with extra bolts
ARB2	2 1/8" to 4 1/8" adjustment for 15 lb. rails
C-160	Rail clip for 12lb. & 15lb. rail
C-161	Rail clip for 8lb. rail

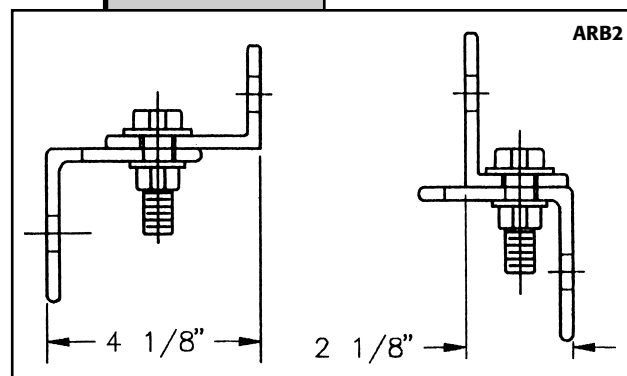
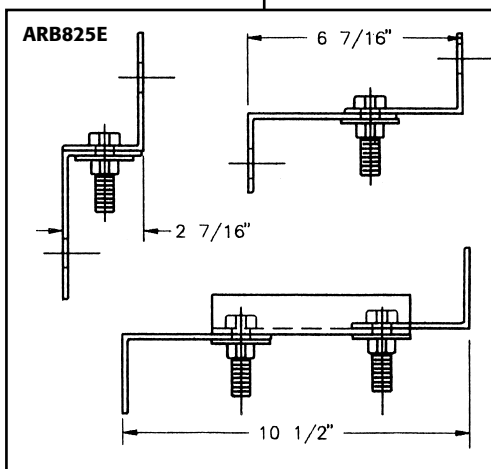
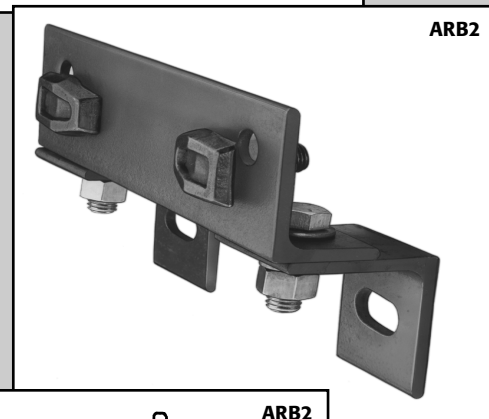
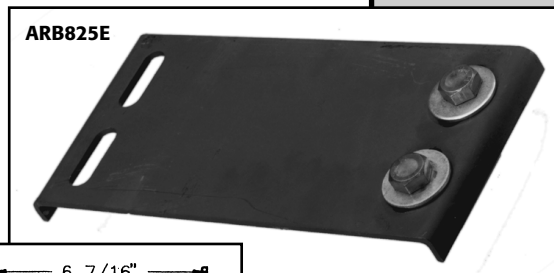
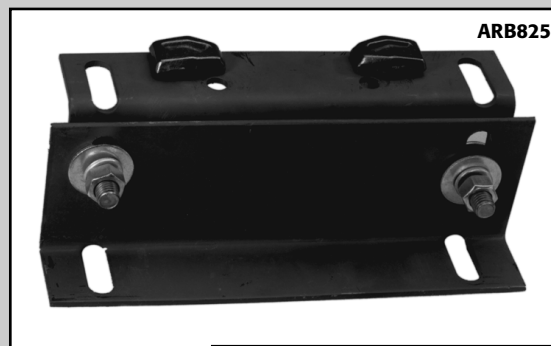
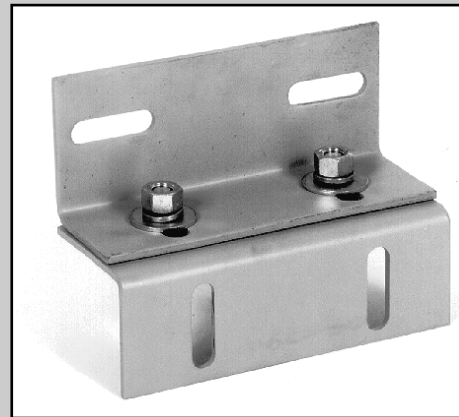

Questions? Answers at...
(866) CED-ELEV • (866) 233-3538
www.cedelevator.com

SAFETY EQUIPMENT

25

In this Section

Field Employees' Safety Handbook	25.2
Safety Mirrors	25.2
Safety Glasses & Gloves	25.2
GFCI Devices	25.3
Lockout/Tagout Devices	25.3
Square Mesh Wire Cloth	25.4
PearlWeave Hoistway Safety Netting	25.4
Hoistway Guard Systems	25.4
Pedestrian Barricades	25.5
Counterweight Derailment System	25.6
Seismic Switch	25.6

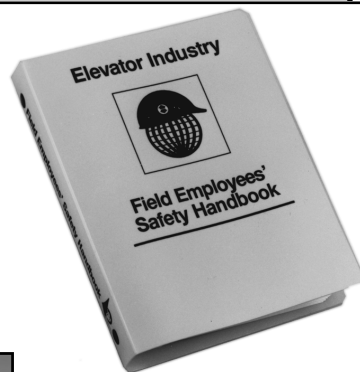

MEL99

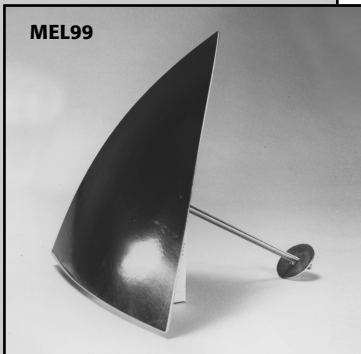

MEL800

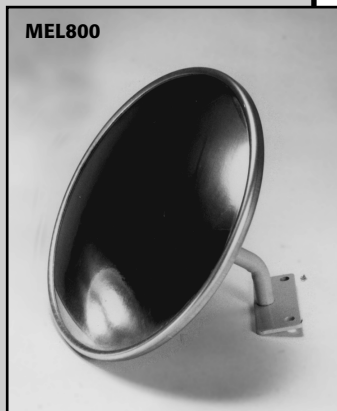

Safety Handbook, Mirrors Glasses & Gloves

Field Employees' Safety Handbook

- 146-page, loose-leaf style
 - User-friendly format
 - Improved illustrations
 - Heavy-duty, poly-vinyl yellow binder
- Part Number **ELEVESH**

Safety Mirrors

- Meet state law requirements
- High polished stainless metal mirror finish
- Unbreakable design
- Easy to maintain
- Tamper-proof installation
- Mounting hardware included

Part Number	Description
MEL99	10" triangular, secured from outside of cab bracket with set screw.
MEL800	8" round, quick, easy surface mounting with metal rod.

Safety Glasses

Flanker—Clear, Smoke
Sectorlite—Yellow, Mirror, Clear, Smoke
Strobe—Clear, Smoke

Safety Gloves

Available in small, medium, large, x-large and xx-large. Various colors available.
Models: Framed Cut Finger; Grunt; Handler; Palmer; Tacker.

Questions? Answers at...
(866) CED-ELEV • (866) 233-3538
www.cedlevator.com

GFCI Devices Cords, Lights, Boxes & Lockout/Tagout Devices

In-line GFCI

Great for use in wet areas and construction site applications, this In-Line Cord is available in either 120V/15A, 14/3 AWG or 240V/20A, 12/3 AWG. Extension cord length varies from 1', 6', 25' and 50'. If there's a trip or power outage, manual reset is required, thus preventing unmonitored equipment start up.

GFCI Trouble Light

Perfect for industrial uses where light and electrical safety are necessary. Protected by an all metal housing and includes one extra NEMA 5-15 convenience receptacle at the light end. A 25' extension cord is attached.

GFCI Cord, 6ft.

Everyone who uses an electric tool needs to ensure his own electrical protection! This 6-foot outdoor cord has a 15 amp. GFCI built into the male plug, with a test/reset button included. The other end has a molded-on POWERLITE power indicator plug that illuminates to show that the power is on. Meets or exceeds UL, OSHA or NEMA specifications.

GFCI Protected Quad Box

This 20 amp quad box is built to protect both pairs of receptacles. Its special features include T-slotted receptacles to allow both 15 and 20 ampere rated tools, with either NEMA 5-15 or NEMA 5-20 plugs. The second feature includes a "fast breaker" which is built into the heavy resistant box. This is great for fast reset should a power overload occur. Available in both 25' and 50' lengths.

Masterlock Personal Safety Lockout Kit

Part Number **1457E410KA** includes:

- (1) 51017: Ultra durable safety carry case
- (3) 410Red: Padlocks, keyed alike
- (1) 7C5Red: Circuit breaker padlock
- (1) 420: Lockout hasp
- (1) 427: Labeled snap-on red lockout hasp
- (2) 491B: Griptight circuit breaker lockout devices for tall or wide toggles
- (3) 493B: Griptight circuit breaker lockout devices for standard single 9 double toggles
- (1) 493B: Universal wall switch lockout device
- (1) 497A: 12 pack 'danger do not operate' tags

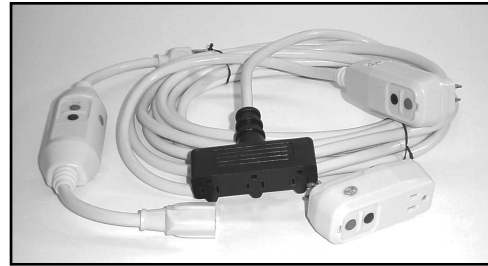
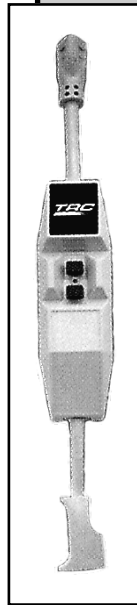

Tri-Tap GFCI Cords & GFCI Receptacle Adapters

Part Number	Description
30326808-08	25ft. Tri-tap GFCI Cord
30326809-08	50ft. Tri-tap GFCI Cord
14650-013-6	GFCI Receptacle Adapter
30338018-08	18ft. GFCI Cord
30338022-08	6ft. GFCI Cord

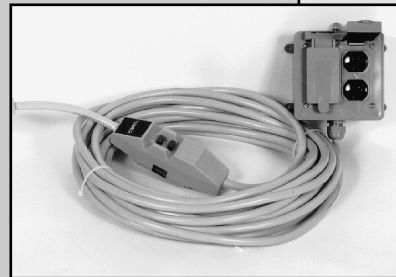
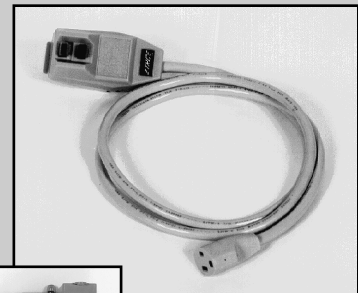

Questions? Answers at...
(866) CED-ELEV • (866) 233-3538
www.cedelevator.com

Barclays California Code of Regulations

(applies to 1970–August 8, 1997)

2.(c) Guarding of Counterweights in a Multiple-Elevator Hoistway

(1) Where counterweights are located between elevators in a hoistway having more than one elevator, the counterweight shall be guarded for the entire height of the hoistway. The guard shall extend at least 6 inches horizontally beyond each counterweight rail. The guard shall be made from wire-mesh material equal to or stronger than .048-inch diameter wire with openings not exceeding 1/2-inch, securely fastened to keep the guard taut and plumb.

(2) The guarding of counterweights required in Section 3013(c)(1) shall be accomplished within three years of the effective date of this regulation. (Title 24, Part 7, Section 7–3013.)

OSHA Regulations require the installation of screening between adjacent elevator hoistways to protect workers from injury.

The National Elevator Industry's Field Employee Safety Handbook, Section 8.3, "Hoistway Screening," requires that, "When an elevator is operating in a multiple hoistway, and construction or modernization work is to be performed, in an adjacent position of that multiple hoistway, that portion of the elevator hoistway where the work is to be performed, shall be fully separated."

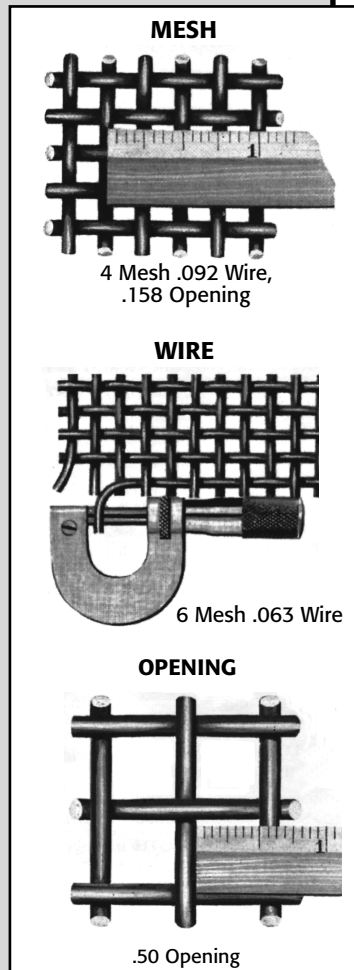

Hoistway Safety Netting & Guard System

Square Mesh Wire Cloth

- Galvanized, Hot-Dipped after Welded
- Mesh: 1/2" x 1/2" (center to center) x.063 GAW

AVAILABLE IN:

- 100 Sqft Roll, 2'X50'
- 200 Sqft Roll, 2'X100'
- 200 Sqft Roll, 4'X50'
- 400 Sqft Roll, 4'X100'

Mesh

Number of openings per lineal inch. Measured from the center of wires. The number of openings precedes the word "Mesh."

Wire

The diameter of wire (in decimals) used in weaving cloth.

Opening

The size of clear opening between parallel wires. For a given mesh, the space is determined by the diameter of wire used.

PearlWeave Hoistway Safety Netting

PearlWeave netting, when installed vertically inside elevator hoistways, provides protection equivalent to that of wire mesh. It replaces screening behind traveling cables, protects counterweight frames, and most important, protects workers working inside of one hoistway from straying into the adjacent hoistway or the area between counterweight rails, thereby preventing serious injury, and even loss of life.

PearlWeave safety netting products are lightweight, durable and easier to use than traditional wire meshes, while exceeding their strength characteristics. Our chemical- and mildew-resistant products, are also flame retardant, and if burned, will not emit toxins into the hoistway.

Available in 48in. x 150ft. rolls

Part Number **PWSTD48** 3/16" mesh, 126 psi bursting strength 85 psi breaking strength

Hoistway Guard Systems

Hoistway guard systems are used to prevent round and flat traveling cable from striking obstructions in the hoistway and from crossing over into adjoining hoistways. Their use may extend the life span and prevent possible interference of your installed elevator cables.

Our guarding systems are available in two sizes, each containing 100ft x 1.5ft of 1/2"x 1/2" wire mesh, installation hardware, and detailed installation instructions.

Part Number	Description
HGS	Hardware, cloth base mtg. kit, 100' (30.48m)
HGS-EXT	Hardware, mesh and extension mounting kit (used to extend HGS an additional 100ft)

Questions? Answers at...
(866) CED-ELEV • (866) 233-3538
www.cedlevator.com

Pedestrian Barricades

Pedestrian Barricade

The Pedestrian Barricade consists of 3 panels of 36" x 39" and is easily assembled with snap on hinges. It easily protects all pedestrians from open holes or hazardous work. The Pedestrian Barricade forms a complete barrier to protect against unnecessary pedestrian accidents. The continuous bottom "tapping" rail helps blind pedestrians stay away from work area. This barrier is considered a Type I and Type II, meeting all OSHA requirements. One vertical "CAUTION!" sign included.

NOTE: Company logo may be added at additional cost.

Part Number **AG3ESK**



Yellow Plastic Barricade

This barricade is constructed of four 1/4" plywood panels. Painted yellow and black with "Do Not Enter" symbol silk-screened on each panel. Overall dimensions are 42"h x 108"l.

Part Number **15305P** 3/16" mesh, 126 psi bursting strength 85 Psi breaking strength



Fabric E-Z Hook Barricade

This barricade is constructed of metal tubular framing and yellow vinyl/cloth barrier. "Do Not Enter" symbol silk-screened on each of four panels. Plastic plate at bottom serves as a toe guard and multiple units can be attached to one another for larger areas. Overall dimensions are 42"h x 140"l. Plastic plate at bottom serves to increase stability and as a toe guard. Overall dimensions are 39"h x 115"l

Part Number **15306**



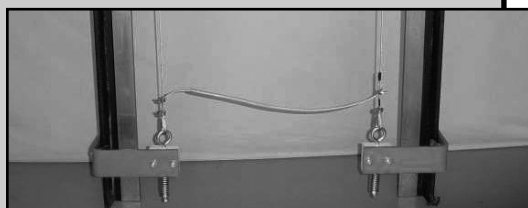

Counterweight Derailment System Seismic Switch

Load Tech Devices Counterweight Derailment System

System designed for quick, easy installation.

- Dual string system provides complete protection
- Factory assembled to reduce field installation time
- Heavy-duty construction suitable for high-rise as well as low-rise installation

Part Number **CDF01**

Seismic Switch

The introduction of new solid-state accelerometers has made possible the development of a more robust and stable Seismic Switch for protection and control of elevators during earthquakes.

- Can be installed in minutes inside the elevator controller or enclosure
- Small footprint
- Dry contact output, controller area network port and RS232 port
- Designed specifically to conform to A.S.M.E. A17.1
- Runs up to 16 hours on optional backup battery
- Backup battery connector included
- Optional backup battery can be obtained at any battery supply store (any 12-volt, sealed lead acid, 1.2-1.4 Amp/Hour battery).

- Fail-Safe

Part Number **SS04**

Questions? Answers at...
(866) CED-ELEV • (866) 233-3538
www.cedlevator.com

SCAVENGER PUMPS

In This Section

Cylinder Head Scavenger Pump	26.2
Heavy-Duty Scavenger Pump . .	26.2
Scavenger Pump Replacement Parts	26.2

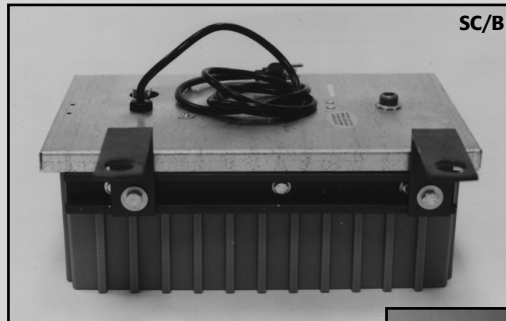

SC/B



SC/B-FR

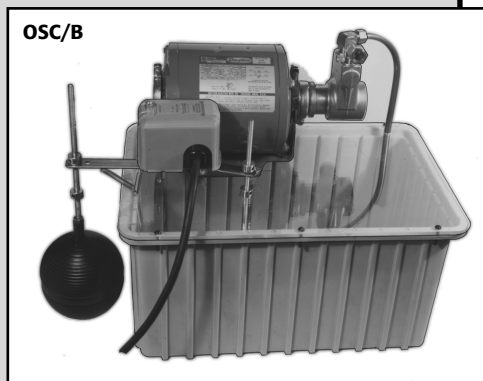

OSC/B

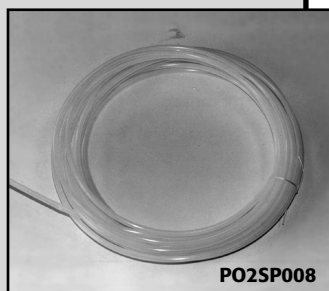

PO2SP008

Scavenger Pumps & Parts Oil Transfer Pump

Cylinder Head Scavenger Pump

Constructed of ribbed reinforced polyethylene with 16-gauge welded steel cover and submersible pump. 2-gallon capacity. Pumps 10 to 12 ft. Tank: 15" w x 10" d x 6" h.

Part Number	Description
SC/B	Reinforced external mounting brackets to mount off cylinder headbolts.
SC/B2	Without mounting brackets
SC/B2FR	Flood Control Switch shuts off pump if pit begins to fill with water.

Heavy-Duty Scavenger Pump (Pit Return Pump)

Ribbed reinforced polyethylene container will not corrode. The clear, 1/4" lexan top allows for full visibility of the inner workings of the unit. Tank: 15" w x 10" d x 8" h

- UL approved motor and cord
- 100 ft. head
- 100 ft. plastic tubing with fittings
- Includes flood control reset
- 71 mesh filter (200 micron)
- 1/4 HP 115VAC motor * Also 1/3 HP Available

Part Number **OSC/B**

Scavenger Pump Replacement Parts

Part Number	Description
15SP004	Stainless steel float & rod
PO2SP008	1/2" plastic tubing in 100 ft. lengths (included with OSC/B pump).
21SP004	Motor, 1/4 HP phase, 115 VAC
21SP011	Motor, 1/3 HP, 115 VAC

Questions? Answers at...
(866) CED-ELEV • (866) 233-3538
www.cedlevator.com

SIGNS, BRAILLE TAGS & CERTIFICATE FRAMES

27

In this Section

Die Cast Signs

Cab Control Plates 27.2-5

Door Jamb Plates 27.7

Metal Stamped Signs

Cab Control Plates 27.6

Door Jamb Plates 27.8

Screen Printed Specialty Signs

Firefighter's Operation 27.9

In Case of Fire, Medical,
Identification 27.10-11

Acrylic Signs

In Case of Fire 27.12

Escalator Safety,
No Smoking, Capacity 27.13

Main Station or Phase 1 27.14

Car Station or Phase 2 27.15

Warning, Danger,
Data Tags 27.16-17

Certificate Frames 27.18

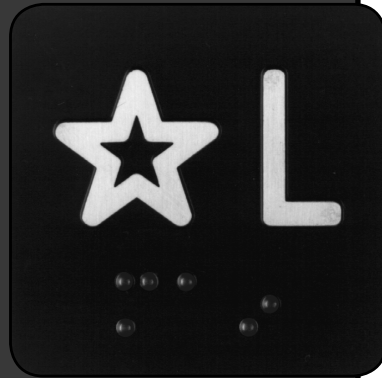
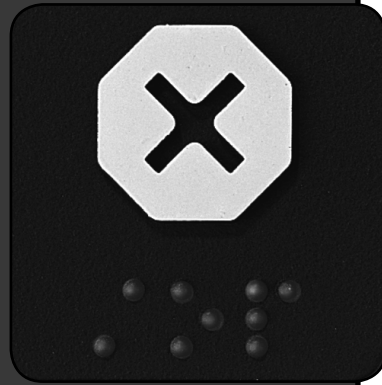

Cab Plates — Die Cast

CC2

(ANSI Compliant)

Size

1.250" square
0.085" material thickness (0.125" with FLC5)
0.125" corner radius
0.625" character height

Designation Color: Natural, painted

Background Color: Painted

Mounting: Front Mechanical or Back Flange
Mounting (**FLM1, FLM2**)

Finishes: See Standard Finishes

CC3

(ANSI Compliant)

Size

1.50" square
0.060" material thickness
0.125" corner radius
0.625" character height

Designation Color: Natural, Painted

Background Color: Painted

Mounting: Front Mechanical or Back Flange
Mounting (**FLM1, FLM2**)

Finishes: See Standard Finishes

NOTE: Can be fitted with shims to adapt to your panel thickness to achieve "flush" mount design.

CC5

(ANSI Compliant)

Size

1.375" round
0.085" material thickness
0.625" character height

Designation Color: Natural, Painted

Background Color: Painted

Mounting: Front Mechanical or Back Flange
Mounting (**FLM1, FLM2**)

Finishes: See Standard Finishes

NOTE: Can be fitted with shims to adapt to your panel thickness to achieve "flush" mount design.

Standard Finishes: Satin Nickel, Satin Bronze, Mirrored Stainless, Mirrored Bronze, Black & White, Nickel Painted, Goldleaf Painted, US26

Questions? Answers at...
(866) CED-ELEV • (866) 233-3538
www.cedlevator.com

Cab Plates — Die Cast

CC6

(ANSI Compliant)

Size

1.50" round
0.060", material thickness
0.625" character height

Designation Color: Natural, painted

Background Color: Painted

Mounting: Front mechanical or back flange mounting (**FLM1 or FLM2**)

Finishes: See Standard Finishes

NOTE: Can be fitted with shims to adapt to your panel thickness to achieve "flush" mount design. Retrofit version to fit existing 1.375" cut out.



CC7

Size

0.755" x 1.13"
0.063", 0.100" material thickness
0.125" corner radius
0.628" character height

Designation Color: Natural, painted

Background Color: Painted

Mounting: Front mechanical

Finishes: See Standard Finishes

NOTE: Can be fitted with shims to adapt to your panel thickness to achieve "flush" mount design.



CHLP

(ANSI Compliant)

Size

2.425" x 1.250"
0.0875" material thickness
0.625" character height

Designation Color: Natural, painted

Background Color: Painted

Mounting: Front mechanical

Finishes: See Standard Finishes



Optional Mounting Flanges & Retainers available on request

Questions? Answers at...
(866) CED-ELEV • (866) 233-3538
www.cedelevator.com



CK1

(ANSI Compliant)

Size

2.050" x 1.375"
0.065" material thickness
0.625" character height

Designation Color: Natural, painted

Background Color: Painted

Mounting: Front mechanical

Finishes: See Standard Finishes

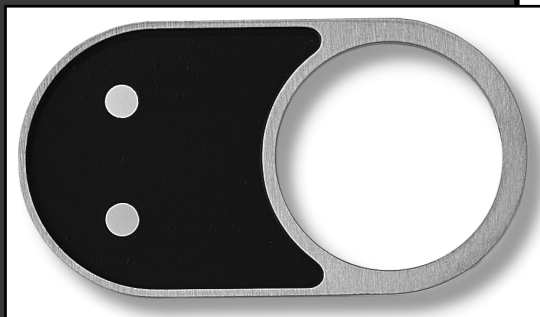

CW1

Size

2.75" x 1.50"
0.120" material thickness

Background Color: Natural, painted

Mounting: Reference CW2

Finishes: See Standard Finishes (uS26 not available)

NOTE: Button opening available in 1.204," 1.270," 1.375," and custom diameters. Available in custom colors to meet parking garage level requirements.

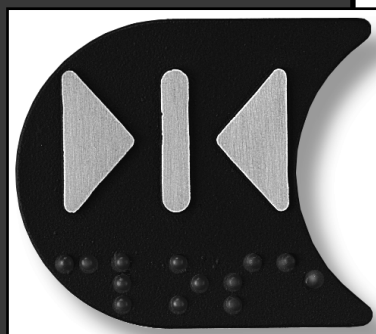

CW2

(ANSI Compliant)

Size

1.565" x 1.358"
0.055" material thickness
0.625" character height

Designation Color: Natural, painted

Background Color: Painted

Mounting: Front mechanical

Finishes: See Standard Finishes

Standard Finishes: Satin Nickel, Satin Bronze, Mirrored Stainless, Mirrored Bronze, Black & White, Nickel Painted, Goldleaf Painted, US26

Cab Plates — Die Cast

CIP1 & RIP1

(ANSI Compliant)

Size

1.575" x 1.063"
0.059" corner radius
0.052" material thickness
(CIP1 Die Cast Metal, RIP1 Plastic)
1.499" character height

Designation Color: Natural, painted

Background Color: Painted

Mounting: Adhesive

Finishes: See Standard Finishes
(RIP1 Black & White only)

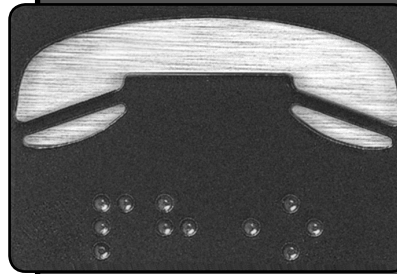

CM1

Size

3.0" x 3.0" [Use 2.50" diameter opening]
0.173" material thickness

Designation Color: Painted

Background Color: Natural

Mounting: Back Flange Mounting

Finishes: Satin Stainless, Satin Bronze,
Mirrored Stainless, Mirrored Bronze



CPI

Size

3.375" x 1.125"
Square corner radius, 0.120" thick.
0.25" raised capacity height
0.255" engraved weight height

Designation Color: Natural, painted

Background Color: Painted

Mounting: Front mechanical

Finishes: Satin Stainless, Satin Bronze, and Black

NOTE: Capacity plates are available in any duty/weight, English, metric or both.



CST1

Size

3.50" square
0.100 material thickness
0.125" (3.2mm) corner radius

Designation Color: Natural, Painted

Background Color: Natural, Painted

Mounting: Front mechanical or back flange
mounting (FLM4)

Finishes: Satin Stainless, Satin Bronze, Mirrored
Stainless, Mirrored Bronze, Blue and White



**Optional Mounting Flanges & Retainers
available on request**

Questions? Answers at...
(866) CED-ELEV • (866) 233-3538
www.cedlevator.com

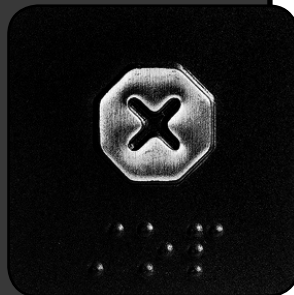
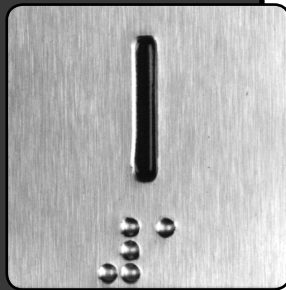

Cab Plates

Metal Stamped, Resin

EC1R

Size

EC1R: 1.375" round; **EC15R:** 1.50" round
0.032" material thickness
0.625" character height

Designation Color: Natural, Painted

Background Color: Natural, Painted

Mounting: Adhesive or One Threaded Stud

Finishes: Satin Stainless, Satin Bronze, Mirrored Stainless, Mirrored Bronze, Black and White

EC1 (ANSI Compliant)

Size

EC1: 1.250" square; .0625" or .125" corner radius
EC15: 1.50" square; .0625" corner radius
0.032" material thickness
0.625" character height

Designation Color: Natural, Painted

Background Color: Natural, Painted

Mounting: Adhesive or One Threaded Stud

Finishes: Satin Stainless, Satin Bronze, Mirrored Stainless, Mirrored Bronze, Black and White

EC1125 (ANSI Compliant)

Size

1.250" square
0.032" material thickness
0.625" or 0.125" corner radius
0.625" character height

Designation Color: Natural, Painted

Background Color: Natural, Painted

Mounting: Adhesive or One Threaded Stud

Finishes: Satin Stainless, Satin Bronze, Mirrored Stainless, Mirrored Bronze, Black and White

RCU1 (ANSI Compliant)

Size

1.358" x 1.955"
0.032" material thickness (Resin)
0.625" character height

Designation Color: White

Background Color: Black

Mounting: Two Studs, Adhesive

Finishes: White, Satin Silver, Satin Gold

Optional Mounting Flanges & Retainers available on request

Questions? Answers at...
(866) CED-ELEV • (866) 233-3538
www.cedlevator.com

Jamb Plates Die Cast

CJ1

Size

3.50" x 2.50"; 0.125" corner radius
0.100" material thickness (Die Cast Metal)
2.00" character height

Designation Color: Natural, Painted

Background Color: Painted

Mounting: Front Mechanical

Finishes: See Standard Finishes



CJ4 (ANSI Compliant)

Size

2.50" x 3.50"; 0.125" corner radius
0.080" material thickness (Die Cast Metal)
2.00" character height

Designation Color: Natural, painted

Background Color: Painted

Mounting: Front Mechanical or Back Flange

Mounting to your panel specifications (FLM5)

Finishes: See Standard Finishes



EJ3 (ANSI Compliant)

Size

3.00" x 3.50"; .0625" corner radius
0.032" material thickness (Metal Stamped)
2.00" character height

Designation Color: Natural, painted

Background Color: Natural, painted

Mounting: 4 Corner Holes with Drive Pins, Adhesive

Finishes: Satin Stainless, Satin Bronze, Mirrored
Stainless, Mirrored Bronze, Black and White



EJ4 (ANSI Compliant)

Size

4.00" square
0.032" material thickness (Die Cast Metal)
0.0625" corner radius
2.00" character height

Designation Color: Natural, painted

Background Color: Natural, painted

Mounting: 4 Corner Holes with Drive Pins, Adhesive,
5/32 Weld Studs

Finishes: Satin Stainless, Satin Bronze, Mirrored
Stainless, Mirrored Bronze, Black and White



CA COMPLIANT

Standard Finishes: Satin Nickel, Satin Bronze,
Mirrored Stainless, Mirrored Bronze, Black & White,
Nickel Painted, Goldleaf Painted, US26

Questions? Answers at...
(866) CED-ELEV • (866) 233-3538
www.cedlevator.com

PLG

EJ45

Size

4.00" x 5.00" (This size used for 3-character combos)
0.032" material thickness (Metal Stamped)
0.0625" corner radius
2.00" character height

Designation Color: Natural, painted

Background Color: Natural, painted

Mounting: 4 Corner Holes with Drive Pins, Adhesive

Finishes: Satin Stainless, Satin Bronze, Mirrored Stainless, Mirrored Bronze, Black and White

2

RJ4 (ANSI Compliant)

Size

4.00" square
0.080" material thickness (Resin)
0.0625" corner radius
2.00" character height

Designation Color: White

Background Color: Black

Mounting: Adhesive

Finishes: White, Satin Silver, Satin Gold

ELEVATOR

10

SVB229 (A17.1-2000)

4.00" square plate
3.00" character height

(Elevator number designation requirement)

one per jamb, mounted adjacent to or on every elevator entrance at the designated level per A17.1-2000 2.29.1

Specialty Signs Screen Printed

SVB12 (Phase II ANSI 1993)

SVB41 (Phase II ANSI 1996)

Size

6.90" x 4.40"

Material thickness: 0.032" metal / 0.020" Lexan

Square corner radius

Character height: 0.25" title / 0.188" text

Designation Color: Painted

Background Color:

SVB12: Natural, white **SVB41:** Black

Mounting: Adhesive

Finishes: Satin Stainless, Satin Bronze, Mirrored Stainless, Mirrored Bronze, Matte Plastic

SVB59 (Phase II ANSI 1998)

SVB79 (Phase II ANSI 2000)

Phase II Firefighter's Instructions
ANSI A17.1-2000 (Latest Code) not pictured.

Size

6.9" x 5.275"

Material thickness: 0.032" metal / 0.020" Lexan

Square corner radius

Character height: 0.25" title/0.188" text

Designation Color: Painted

Background Color:

SVB59: Natural, white **SVB79:** Black

Mounting: Adhesive

Finishes: Satin Stainless, Satin Bronze, Mirrored Stainless, Mirrored Bronze, Matte Plastic

SVB6/SVB70/SVB70R (Phase I ANSI Compliant)

Size

SVB6 4.00" x 1.45";

SVB70/SVB70R 3.375" x 3.00"

Material thickness: 0.032" metal / 0.020" Lexan

Square corner radius

Character height: 0.25"

Designation Color: Black

Background Color: Natural, white

Mounting: Adhesive

Finishes: Satin Stainless, Satin Bronze, Mirrored Stainless, Mirrored Bronze, Matte Plastic

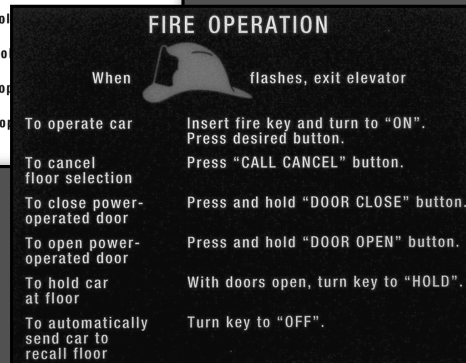
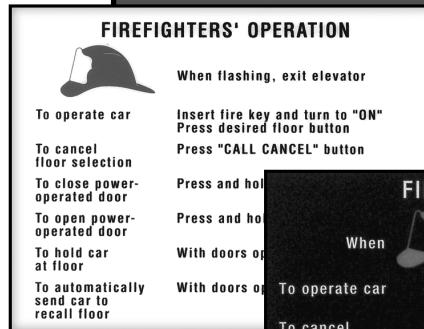
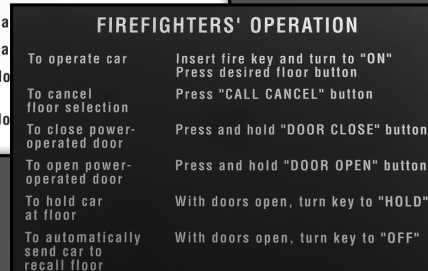
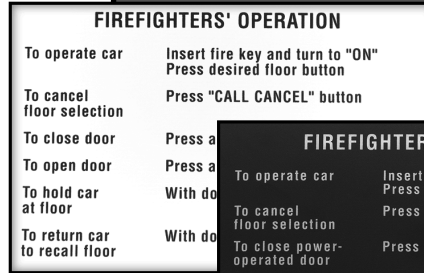

SVB6



SVB70R
ALSO AVAILABLE WITH
KEY "BYPASS" (SVB70)

Questions? Answers at...
(866) CED-ELEV • (866) 233-3538
www.cedlevator.com



In Case Of Fire
Elevators Are Out Of Service



Use Exit

IN CASE OF FIRE
USE STAIRWAY
FOR EXIT



DO NOT USE
ELEVATOR

Specialty Signs Screen Printed

SVB80

Size

4.00" square
Material thickness: 0.032" metal / 0.020" Lexan
Square corner radius
3.00" character height

Designation Color: Blue

Background Color: Natural, white

Mounting: Adhesive

Finishes: Satin Stainless, Satin Bronze, Mirrored
Stainless, Mirrored Bronze, Matte Plastic

SVB13 (ANSI Compliant, Appendix H, Appendix O)

Size

5.00" x 8.00"
Material thickness: 0.032" metal / 0.020" Lexan
Square corner radius
0.30" character height-text
6.00" character height-pictogram

Designation Color: Black text, red flame

Background Color: Natural, white

Mounting: Adhesive

Finishes: Satin Stainless, Satin Muntz, Mirrored
Stainless, Mirrored Muntz, Matte Plastic

SVB30 (California Code)

Size

5.00" x 8.00"
Material thickness: 0.032" metal / 0.020" Lexan
Square corner radius
0.50" character height-text
4.00" character height-pictogram

Designation Color: Black text, red flame

Background Color: Natural, white

Mounting: Adhesive

Finishes: Satin Stainless, Satin Muntz, Mirrored
Stainless, Mirrored Muntz, Matte Plastic

Questions? Answers at...

(866) CED-ELEV • (866) 233-3538
www.cedlevator.com

Specialty Signs Screen Printed

SUB229 (ANSI Compliant)
(Elevator Identification for Entrance)

Size
4.00" x 4.00"
Material thickness: 0.030" metal
Mounting: Adhesive
Finishes: Black Background with White Text
or Stainless Background with Black Text



SUB229COP
(Elevator Identification for COP)

Size
3.250" x 1.250"
Material thickness: 0.020" aluminum
Mounting: Adhesive
Finishes: Black background with white text
or Stainless background with black text



R380 & R580 (Meets ANSI, Appendix H, Appendix O)
(Insert Only)

Size
R380: 4.110" x 3.120"
R580: 6.0" x 4.250" (Flame size)
Material thickness: Designed for 11-gauge or less panel thickness – Resin
Designation Color: Black text, red flame
Background Color: White
Mounting: Flanged insert; laser cutout file provided with part purchase.

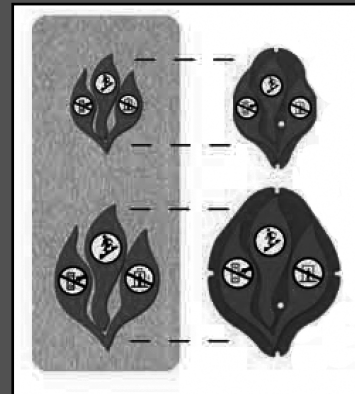
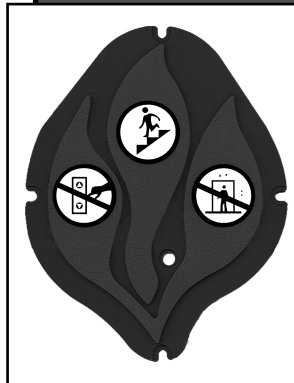

SVB17LA
Size

6.75" x 2.00"
Material thickness: 0.020" aluminum
Mounting: Adhesive
Finishes: satin stainless, black text

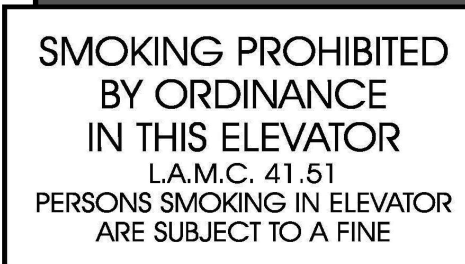

Questions? Answers at...
(866) CED-ELEV • (866) 233-3538
www.cedelevator.com

'In Case of Fire' Signs

SIGNS & BRAILLE TAGS



4001 (6"x7") 4001-A (8"x10")
4001-B (3"x3.5")



4011 (6"x7") 4011-A (8"x10")
4011-B (3"x3.5")



4002 (6"x7")



4021 (6"x7") 4021-A (8"x10")
4021-B (3"x3.5")



4501 (6"x7") 4051-A (8"x10")
4501-B (3"x3.5")



4601 (6"x7")



4113 (6"x7")



4071 (6"x7") 4071-A (8"x10")
4071-B (3"x3.5")



C4001NS1-A (6"x9")
OPTIONAL TEXT AVAILABLE



C4001-L (6"x9")
OPTIONAL TEXT AVAILABLE



4002-D (3.5"x8.5")



4011-D (3.5"x8.5")



4001-SP (6"x7")



4011-SP (6"x7")



4002-C (8"x3.5")

Questions? Answers at...

(866) CED-ELEV • (866) 233-3538
www.cedlevator.com

Acrylic Escalator Safety, No Smoking & Capacity

Signs

The long-lasting anti-fading signs on the following pages are available with stainless steel, antique brass, brass and aluminum backgrounds. All come with a 3M adhesive backing.

Decals

Many of the elevator and escalator signs on the following pages are available as decals. Custom decals are also available. All decals are produced on 3mm decal material.

Data Tags

Data tags are made from 1/32" aluminum, or 1/32" enamel coated aluminum. Most data tags are custom made for individual companies. If you need a custom sign, fax us an example and we can have it recreated. All tags are available with holes or a 3M adhesive backing



ES-1 (4"x8.75")



ES-SR1 (4.5"x7")



9102 (5"x7")



ES-12 (4"x8.75")

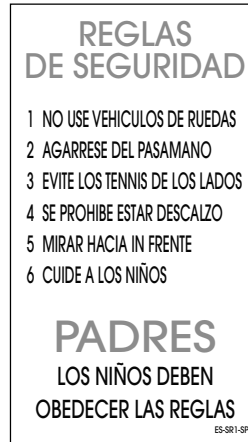

ES-SR1-SP (4"x7")



9101(5"x7")



ES-12-SP (4"x8.75")



ES-42



9103-LA (5"x8")



9301 (10x3.5")

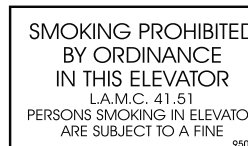

9502



CAP-11A (4.5"x1") CAP-11 (10"x3')

Questions? Answers at...
(866) CED-ELEV • (866) 233-3538
www.cedelevator.com

Main Station or Phase I Signs

FIRE OR EMERGENCY ELEVATOR OPERATION

KEY OFF:

- NORMAL ELEVATOR OPERATION

KEY ON:

- RECALLS ELEVATOR TO THIS FLOOR
- KEY CAN BE REMOVED IN THIS POSITION

6001

FIRE OR EMERGENCY ELEVATOR OPERATION

KEY OFF:

- NORMAL ELEVATOR OPERATION

KEY ON:

- RECALLS ELEVATOR TO THIS FLOOR
- KEY CAN BE REMOVED IN THIS POSITION TO OPERATE CAR STATION

6002

FIRE OR EMERGENCY ELEVATOR OPERATION

KEY OFF:

- NORMAL ELEVATOR OPERATION

KEY ON:

- RECALLS ELEVATOR TO THIS FLOOR
- KEY CAN BE REMOVED IN THIS POSITION

KEY BY-PASS:

- OVERRIDES HEAT AND SMOKE SENSORS TO ALLOW NORMAL ELEVATOR OPERATION

6102

FIRE OR EMERGENCY ELEVATOR OPERATION

KEY OFF:

- NORMAL ELEVATOR OPERATION

KEY ON:

- RECALLS ELEVATOR TO THIS FLOOR
- KEY CAN BE REMOVED IN THIS POSITION TO OPERATE CAR STATION

KEY BY-PASS:

- OVERRIDES HEAT AND SMOKE SENSORS TO ALLOW NORMAL ELEVATOR OPERATION

6103

FIRE OR EMERGENCY ELEVATOR OPERATION

KEY ON:

- RECALLS ELEVATOR TO RECALL FLOOR

KEY BY-PASS:

- OVERRIDES HEAT AND SMOKE SENSORS

KEY OFF:

- RESTORES NORMAL SERVICES
- TURN KEY TO BY-PASS, THEN OFF

6201

FIRE OR EMERGENCY ELEVATOR OPERATION

FOR RECALLING ELEVATORS

- "ON" POSITION RECALLS ELEVATORS TO THIS LANDING
- "OFF" POSITION ALLOWS AUTOMATIC ELEVATOR OPERATION

6301

FIRE OR EMERGENCY ELEVATOR OPERATION

FOR RECALLING ELEVATORS

- "ON" POSITION RECALLS ELEVATORS TO THIS LANDING
- "OFF" POSITION ALLOWS AUTOMATIC ELEVATOR OPERATION
- "BY-PASS" POSITION OVERRIDES HEAT AND SMOKE SENSORS TO ALLOW NORMAL ELEVATOR OPERATION

6401

FIRE OR EMERGENCY ELEVATOR OPERATION

FOR FIRE DEPARTMENT USE ONLY IN HALL OPERATION

- TO RECALL ELEVATOR TO THIS FLOOR TURN FIRE KEY TO "ON"
- TO BY-PASS SMOKE DETECTORS TURN FIRE KEY TO "BY-PASS"
- TO RESTORE NORMAL SERVICE TURN FIRE KEY TO "OFF"

6501

FIRE OR EMERGENCY ELEVATOR OPERATION

FOR RECALLING ELEVATORS

- "ON" POSITION RECALLS ELEVATORS TO THIS LANDING
- "OFF" POSITION ALLOWS AUTOMATIC ELEVATOR OPERATION
- "BY-PASS" POSITION OVERRIDES HEAT AND SMOKE SENSORS TO ALLOW NORMAL ELEVATOR OPERATION

6601

FIREFIGHTERS' OPERATION

TO RECALL ELEVATORS

- INSERT FIRE KEY AND TURN TO "ON" TO RECALL ELEVATOR TO THIS FLOOR
- TURN KEY TO "BY-PASS" TO OVERRIDE AND TO RESET THE SMOKE SENSORS AND TO ALLOW FOR NORMAL OPERATION OF THE ELEVATOR
- TURN KEY TO "OFF" TO ALLOW FOR NORMAL ELEVATOR OPERATION

6931

FIREFIGHTERS' OPERATION

- INSERT FIRE KEY AND TURN TO "ON" TO RECALL ELEVATOR TO THIS FLOOR
- TURN KEY TO "RESET" TO OVERRIDE AND TO RESET THE SMOKE SENSORS AND TO ALLOW FOR NORMAL OPERATION OF THE ELEVATOR
- TURN KEY TO "OFF" TO ALLOW FOR NORMAL ELEVATOR OPERATION

6935

TURN TO:

"ON" FOR FIRE SERVICE

"OFF" FOR NORMAL OPERATION

6302

TURN TO:

"ON" FOR FIRE SERVICE

"BY-PASS" TO OVERRIDE DETECTOR

"OFF" FOR NORMAL OPERATION

6502

FIRE OR EMERGENCY ELEVATOR OPERATION MAIN STATION

KEY OFF:

- NORMAL ELEVATOR OPERATION

KEY ON:

- RECALLS ELEVATORS TO THIS FLOOR
- KEY CAN BE REMOVED IN THIS POSITION TO OPERATE CAR STATION

KEY BY-PASS:

- OVERRIDES HEAT AND SMOKE SENSORS TO ALLOW NORMAL ELEVATOR OPERATION

KEY OFF:

- NORMAL ELEVATOR OPERATION

KEY ON:

- PLACES ELEVATOR IN EMERGENCY SERVICE
- TO CLOSE DOORS APPLY CONTINUOUS PRESSURE TO "DOOR CLOSE" BUTTON
- PUSH BUTTON FOR FLOOR DESIRED
- TO OPEN DOORS APPLY CONTINUOUS PRESSURE TO "DOOR OPEN" BUTTON

5002

FIRE OR EMERGENCY ELEVATOR OPERATION MAIN STATION

KEY OFF:

- NORMAL ELEVATOR OPERATION

KEY ON:

- RECALLS ELEVATOR TO THIS FLOOR
- KEY CAN BE REMOVED IN THIS POSITION

KEY BY-PASS:

- OVERRIDES HEAT AND SMOKE SENSORS TO ALLOW NORMAL ELEVATOR OPERATION

KEY OFF:

- NORMAL ELEVATOR OPERATION

KEY ON:

- PLACES ELEVATOR IN EMERGENCY SERVICE
- PUSH BUTTON FOR FLOOR DESIRED
- DOORS CLOSE AUTOMATICALLY
- TO OPEN DOORS APPLY CONTINUOUS PRESSURE TO "DOOR OPEN" BUTTON

5005

FIRE OR EMERGENCY ELEVATOR OPERATION MAIN STATION

KEY OFF: NORMAL ELEVATOR OPERATION

KEY ON:

- RECALLS ELEVATOR TO THIS FLOOR
- KEY CAN BE REMOVED IN THIS POSITION TO OPERATE CAR STATION

KEY BY-PASS:

- OVERRIDES HEAT AND SMOKE SENSORS TO ALLOW NORMAL ELEVATOR OPERATION

KEY OFF: NORMAL ELEVATOR OPERATION

KEY ON:

- PLACES ELEVATOR IN EMERGENCY SERVICE
- PUSH BUTTON FOR FLOOR DESIRED
- DOORS CLOSE AUTOMATICALLY
- TO OPEN DOORS APPLY CONTINUOUS PRESSURE TO "DOOR OPEN" BUTTON

KEY BY-PASS:

- APPLY CONTINUOUS PRESSURE TO KEY IF CAR FAILS TO START AFTER PRESSING BUTTON FOR RETURN TO MAIN FLOOR

5101

FIRE OR EMERGENCY ELEVATOR OPERATION MAIN STATION

KEY ON: RECALLS ELEVATOR TO THIS FLOOR

- KEY CAN BE REMOVED IN THIS POSITION TO OPERATE CAR STATION

KEY OFF: NORMAL ELEVATOR OPERATION

KEY BY-PASS:

- OVERRIDES HEAT AND SMOKE SENSORS TO ALLOW NORMAL ELEVATOR OPERATION

KEY OFF: NORMAL ELEVATOR OPERATION

- RETURNS ELEVATOR TO RECALL FLOOR WHEN "MAIN RECALL" IS EFFECTIVE

KEY HOLD: ELEVATOR REMAINS AT FLOOR WITH DOORS OPEN

KEY ON:

- PLACES ELEVATOR IN EMERGENCY SERVICE
- TO CLOSE DOORS APPLY CONTINUOUS PRESSURE TO "DOOR CLOSE" BUTTON
- PUSH BUTTON FOR FLOOR DESIRED
- TO CANCEL FLOOR CALL PUSH DESIGNATED BUTTON
- TO OPEN DOORS APPLY CONTINUOUS PRESSURE TO "DOOR OPEN" BUTTON

5401

Questions? Answers at...
(866) CED-ELEV • (866) 233-3538
www.cedlevator.com

Car Station or Phase II Signs

**FIRE OR EMERGENCY
ELEVATOR OPERATION**

KEY OFF:

- NORMAL ELEVATOR OPERATION
- RETURNS ELEVATOR TO RECALL FLOOR WHEN "MAIN RECALL" IS EFFECTIVE

KEY ON:

- PLACES ELEVATOR IN EMERGENCY SERVICE
- MAINTAIN PRESSURE ON BUTTON TO CLOSE DOORS
- TO OPEN DOORS APPLY CONTINUOUS PRESSURE TO "DOOR OPEN" BUTTON

ELEVATOR CAR STATION

7001

**FIRE OR EMERGENCY
ELEVATOR OPERATION**

KEY OFF: NORMAL ELEVATOR OPERATION

- RETURNS ELEVATOR TO RECALL FLOOR WHEN "MAIN RECALL" IS EFFECTIVE

KEY HOLD: ELEVATOR REMAINS AT FLOOR WITH DOORS OPEN

KEY ON:

- PLACES ELEVATOR IN EMERGENCY SERVICE
- TO CLOSE DOORS APPLY CONTINUOUS PRESSURE TO "DOOR CLOSE" BUTTON
- PUSH BUTTON FOR FLOOR DESIRED
- TO CANCEL FLOOR CALL PUSH DESIGNATED BUTTON
- TO OPEN DOORS APPLY CONTINUOUS PRESSURE TO "DOOR OPEN" BUTTON

ELEVATOR CAR STATION

7202

**FIRE OR EMERGENCY
ELEVATOR OPERATION**

- TURN FIRE SWITCH TO "ON" POSITION
- PRESS AND HOLD "DOOR CLOSE" BUTTON TO CLOSE DOORS
- PRESS DESIRED FLOOR BUTTON
- PRESS AND HOLD "DOOR OPEN" BUTTON TO OPEN DOORS
- PRESS "CALL CANCEL" BUTTON TO CANCEL CALL
- TURN KEY "OFF" TO ALLOW AUTOMATIC RETURN TO INITIATING LANDING
- TURN KEY TO "HOLD" ELEVATOR AT FLOOR

MAIN STATION

8601

**FIRE OR EMERGENCY
ELEVATOR OPERATION**

KEY OFF:

- NORMAL ELEVATOR OPERATION

KEY ON:

- PLACES ELEVATOR IN EMERGENCY SERVICE
- HOLD BUTTON FOR FLOOR DESIRED
- DOORS CLOSE AUTOMATICALLY
- TO OPEN DOORS APPLY CONTINUOUS PRESSURE TO "DOOR OPEN" BUTTON

ELEVATOR CAR STATION

7002

**FIRE OR EMERGENCY
ELEVATOR OPERATION**

KEY OFF:

- NORMAL ELEVATOR OPERATION

KEY ON:

- PLACES ELEVATOR IN EMERGENCY SERVICE
- PUSH BUTTON FOR FLOOR DESIRED
- HOLD "DOOR CLOSE" BUTTON UNTIL DOORS CLOSE AND CAR STARTS
- TO OPEN DOORS APPLY CONTINUOUS PRESSURE TO "DOOR OPEN" BUTTON

ELEVATOR CAR STATION

8003

**FIRE OR EMERGENCY
ELEVATOR OPERATION**

- TURN FIRE SWITCH TO "ON" POSITION
- PRESS DESIRED FLOOR BUTTON
- PRESS AND HOLD "DOOR CLOSE" BUTTON TO CLOSE DOORS
- PRESS AND HOLD "DOOR OPEN" BUTTON TO OPEN DOORS
- PRESS "RESET" BUTTON TO CANCEL CALL
- TURN KEY "OFF" TO ALLOW AUTOMATIC RETURN TO INITIATING LANDING
- TURN KEY TO "HOLD" ELEVATOR AT FLOOR

ALTERNATE STATION

8602

**FIRE OR EMERGENCY
ELEVATOR OPERATION**

KEY OFF:

- NORMAL ELEVATOR OPERATION

KEY ON:

- PLACES ELEVATOR IN EMERGENCY SERVICE
- PUSH BUTTON FOR FLOOR DESIRED
- MAINTAIN PRESSURE ON BUTTON TO CLOSE DOORS
- TO OPEN DOORS APPLY CONTINUOUS PRESSURE TO "DOOR OPEN" BUTTON

ELEVATOR CAR STATION

7003

**FIRE OR EMERGENCY
ELEVATOR OPERATION**

KEY OFF:

- NORMAL ELEVATOR OPERATION

KEY ON:

- PLACES ELEVATOR IN EMERGENCY SERVICE
- TO CLOSE DOORS APPLY CONTINUOUS PRESSURE TO "DOOR CLOSE" BUTTON
- PUSH BUTTON FOR FLOOR DESIRED
- TO OPEN DOORS APPLY CONTINUOUS PRESSURE TO "DOOR OPEN" BUTTON

ELEVATOR CAR STATION

8004

**FIRE OR EMERGENCY
ELEVATOR OPERATION**

KEY OFF: NORMAL ELEVATOR OPERATION

KEY ON:

- PLACES ELEVATOR IN EMERGENCY SERVICE
- PUSH BUTTON FOR FLOOR DESIRED
- DOORS CLOSE AUTOMATICALLY
- TO CANCEL FLOOR SELECTED PRESS "DOOR OPEN" BUTTON

KEY HOLD: ELEVATOR REMAINS AT FLOOR WITH DOORS OPEN

ELEVATOR CAR STATION

8601

**FIRE OR EMERGENCY
ELEVATOR OPERATION**

KEY OFF:

- NORMAL ELEVATOR OPERATION

KEY ON:

- PLACES ELEVATOR IN EMERGENCY SERVICE
- PUSH FLOOR BUTTON AND HOLD FOR FLOOR DESIRED
- HOLD "DOOR CLOSE" BUTTON UNTIL DOORS CLOSE AND CAR STARTS
- TO OPEN DOORS APPLY CONTINUOUS PRESSURE TO "DOOR OPEN" BUTTON

ELEVATOR CAR STATION

7004

**FIRE OR EMERGENCY
ELEVATOR OPERATION**

KEY OFF:

- NORMAL ELEVATOR OPERATION

KEY ON:

- PLACES ELEVATOR IN EMERGENCY SERVICE
- PUSH BUTTON FOR FLOOR DESIRED
- MAINTAIN PRESSURE ON BUTTON TO CLOSE DOOR
- TO OPEN DOORS APPLY CONTINUOUS PRESSURE TO "DOOR OPEN" BUTTON

ALTERNATE STATION

8005

**FIREFIGHTERS
OPERATION**

TO OPERATE CAR

- INSERT FIRE KEY AND TURN TO "ON"
- PRESS DESIRED FLOOR BUTTON TO CANCEL FLOOR SELECTION
- PRESS "CALL CANCEL" BUTTON TO CLOSE POWER OPERATED DOOR
- PRESS AND HOLD "DOOR CLOSE" BUTTON TO OPEN POWER OPERATED DOOR
- PRESS AND HOLD "DOOR OPEN" BUTTON TO HOLD CAR AT FLOOR
- WITH DOORS OPEN, TURN KEY TO "HOLD" TO AUTOMATICALLY SEND CAR TO RECALL FLOOR WITH DOORS OPEN, TURN KEY TO "OFF"

PHASE-II

8802

**FIRE OR EMERGENCY
ELEVATOR OPERATION**

KEY OFF: NORMAL ELEVATOR OPERATION

- RETURNS ELEVATOR TO RECALL FLOOR WHEN "MAIN RECALL" IS EFFECTIVE

KEY HOLD:

- ELEVATOR REMAINS AT FLOOR WITH DOORS OPEN

KEY ON: PLACES ELEVATOR IN EMERGENCY SERVICE

- TO START ELEVATOR, HOLD BUTTON FOR DESIRED FLOOR WHILE DOORS ARE CLOSING AND UNTIL CAR IS IN MOTION
- TO OPEN DOORS APPLY CONTINUOUS PRESSURE TO "DOOR OPEN" BUTTON

ELEVATOR CAR STATION

7201

**FIRE OR EMERGENCY
ELEVATOR OPERATION**

KEY OFF:

- NORMAL ELEVATOR OPERATION
- RETURNS ELEVATOR TO RECALL FLOOR WHEN "MAIN RECALL" IS EFFECTIVE

KEY HOLD:

- HOLDS CAR AT FLOOR WITH DOORS OPEN

KEY ON:

- PLACES ELEVATOR IN EMERGENCY SERVICE
- TO CLOSE DOORS, APPLY CONTINUOUS PRESSURE TO "DOOR CLOSE" BUTTON
- PUSH BUTTON FOR FLOOR DESIRED
- TO CANCEL FLOOR CALL PUSH DESIGNATED BUTTON
- TO OPEN DOORS APPLY CONTINUOUS PRESSURE TO "DOOR OPEN" BUTTON

ELEVATOR CAR STATION

7210

**FIRE OR EMERGENCY
ELEVATOR OPERATION**

- TURN FIRE SWITCH TO "ON" POSITION
- PRESS DESIRED FLOOR BUTTON
- PRESS AND HOLD "DOOR CLOSE" BUTTON TO CLOSE DOORS
- PRESS AND HOLD "DOOR OPEN" BUTTON TO OPEN DOORS
- PRESS "CALL CANCEL" BUTTON TO CANCEL CALL
- TURN KEY "OFF" AND CLOSE DOORS TO ALLOW AUTOMATIC RETURN TO EMERGENCY LANDING
- TURN KEY TO "HOLD" ELEVATOR AT FLOOR
- WHEN LIGHT AND SIGNAL INDICATE EMERGENCY- CLOSE DOORS SO ELEVATOR CAN RETURN TO EMERGENCY LANDING

ELEVATOR CAR STATION

7402

**FIRE OR EMERGENCY
ELEVATOR OPERATION**

FOR RECALLING ELEVATORS:

- "ON" POSITION RECALLS ELEVATORS TO THIS LANDING
- "OFF" POSITION ALLOWS AUTOMATIC ELEVATOR OPERATION

TO USE ELEVATORS:

- TURN EMERGENCY OPERATION SWITCH TO "ON" POSITION
- PRESS "DOOR CLOSE" BUTTON TO CLOSE DOORS
- PUSH BUTTON FOR FLOOR DESIRED
- TURN EMERGENCY OPERATION SWITCH TO "OFF" POSITION TO RELEASE ELEVATORS

ELEVATOR CAR STATION

7311

Questions? Answers at...
(866) CED-ELEV • (866) 233-3538
www.cedlevator.com

Warning & Danger Signs Data Tags

DANGER

**ELEVATOR
HOISTWAY**

D-51 (10" x 8")

**THIS IS NOT
A PASSENGER ELEVATOR**

NO PERSONS OTHER
THAN THE OPERATOR AND
THE FREIGHT HANDLERS
ARE PERMITTED TO RIDE
ON THE ELEVATOR

FRT-11 (10" x 7.875")

COMPANY NAME HERE
1-YEAR LOAD TEST

ELEVATOR# _____
RELIEF PRESSURE LBS. _____
TEST DATE _____

DT-1Y (3.75" x 1.63")

DANGER

**LOW
OVERHEAD**

D-61 (10" x 7")

CLASS A LOADING

THIS ELEVATOR
DESIGNED FOR
GENERAL FREIGHT
LOADING

FRT-61 (10" x 8")

COMPANY NAME HERE
5-YEAR LOAD TEST

ELEVATOR# _____
RELIEF PRESSURE LBS. _____
TEST DATE _____

DT-5Y (3.75" x 1.50")

DANGER

**ELECTRICAL HAZARD
AUTHORIZED
PERSONNEL ONLY**

D-71 (10" x 8")

WARNING

PARTS OF THE CONTROL PANEL
ARE NOT DE-ENERGIZED
BY THIS SWITCH

W-11 (3.63" x 2.00")

IF ELEVATOR BECOMES INOPERABLE
REMAIN IN CAR UNTIL ASSISTANCE ARRIVES
DO NOT ATTEMPT TO FORCE
DOORS OR HATCH OPEN
PLEASE REMAIN CALM

IEB1 (6" x 2.75")

ST-1 (1 5/16" x 3 1/2")

SAFETY TEST

ELECTRIC

HYDRAULIC

ANNUAL

5-YEAR

3-YEAR

GOVERNOR TEST

RELIEF VALVE TEST

BUFFER TEST

TEST PERFORMED

JAN 2014

FEB 2015

MAR 2016

APR 2017

MAY 2018

JUN 2019

JUL 2020

AUG 2021

SEP 2022

OCT 2023

NOV 2024

DEC 2025

COMP NAME _____

COMPANY NAME _____

PERMIT NO. _____

FULL LOAD PS.I.	BY PASS PS.I.	DATE

DT (3" x 5")

AUTHORIZED PERSONNEL ONLY
STORAGE OR INSTALLATION
OF EQUIPMENT NOT
PERTAINING TO THE ELEVATOR
IS PROHIBITED

EEQ-11 (10" x .25")



STAR-B (3.5" x 3.5")

**HANDICAPPED
ELEVATOR**

HE-2 (8" x 4")

COMPANY NAME HERE

CAPACITY _____ LBS. SPEED _____ FPM
WT. OF CAR _____ LBS. DATE INSTALLED _____
PLUNGER _____ O.D. IN. PLUNGER WALL _____ IN.
STATE PERMIT# _____

DT-HYD (7.38" x 1.50")

COMPANY NAME HERE

CAPACITY _____ LBS. SPEED _____ FPM
WT. OF CAR _____ LBS. DATE INSTALLED _____
NO. OF ROPES _____ TYPE _____ SIZE _____
STRENGTH _____ STATE PERMIT# _____

DT-CBL (7.63" x 2.50")

Warning & Danger Signs Data Tags

<p>Title 8 Group II</p> <p>TITLE 8-II</p>	<p>"KEEP SWITCH CLOSED EXCEPT DURING MAINTENANCE, REPAIRS, AND INSPECTIONS"</p> <p>KSC</p>	<p>ELEVATOR HYDRAULIC OIL LINE</p> <p>HELDEC</p>
<p>Title 8 Group III</p> <p>TITLE 8-III</p>	<p>TITLE 8 GROUP IV ASME A17.1 2004</p> <p>ASME IV</p>	<p>SHOULD THE ELEVATOR DOORS FAIL TO OPEN DO NOT BECOME ALARMED, PLEASE USE BUTTON MARKED "ALARM" OR TELEPHONE (IF FURNISHED) TO SUMMON AID. ELEVATOR COMPANIES ARE ON CALL 24 HOURS A DAY FOR EMERGENCY SERVICE.</p> <p>SEDF-2</p>
<p>MAXIMUM COUNTERWEIGHT RUNBY</p> <p>CWT-RUNBY</p>	<p>ASME A17.1- 1996</p> <p>ASME-I</p>	<p>ALTERATIONS A17.1-1996 PART XII RULE</p> <p>ALT RULES</p>

<p>ASME A17. 1 1996</p> <p>2.5X.5" ASME 1 1996</p>	<p>ALTERATIONS ASME A17.1 2004 Sec. 8.7 RULE</p> <p>2.25X3" ALT RULES 2004</p>	<p>ALTERATIONS ASME A17.1 1996 Sec. 8.7 RULE</p> <p>2.25X3" ALT RULES 1996</p>
<p>ASME A17. 1 2004</p> <p>2.5X.5" ASME 1 2004</p>		
<p>TITLE 8 GROUP 4 ASME A17.1- 1996</p> <p>2.25X.75" ASME 4 1996</p>		
<p>TITLE 8 GROUP 4 ASME A17.1- 2004</p> <p>2.25X.75" ASME 4 2004</p>		
<p>TITLE 8 GROUP II</p> <p>TITLE 8 GROUP II</p>	<p>TITLE 8 GROUP IV ALTERATIONS ASME A17.1 1996 Sec. 8.7 RULE</p> <p>2.25X3" TITLE 8 IV ASME 1996</p>	<p>TITLE 8 GROUP IV ALTERATIONS ASME A17.1 2004 Sec. 8.7 RULE</p> <p>2.25X3" TITLE 8 IV ASME 2004</p>
<p>TITLE 8 GROUP III</p> <p>TITLE 8 GROUP III</p>		
<p>TITLE 8 GROUP IV</p> <p>TITLE 8 GROUP IV</p>		
<p>FIREFIGHTERS OPERATION TO RECALL ELEVATORS INSEIRE KEY AND TURN TO "ON"</p> <p>6107</p>	<p>EMERGENCY ELEVATOR REPAIR VEHICLE</p> <p>EEV1 (9" X 6")</p>	

Certificate Frames

Certificate Frames

- Stainless steel, bronze or mirrored stainless finish with acrylic windows
- Hidden mounting screws prevent vandalism
- Mounts vertically or horizontally
- Available with "NO SMOKING" silk screened on frames. Add **NS** to part number (short side) or **NSL** (long side)

Replacement Parts

Stainless Part Number	Bronze Part Number	Mirrored Stainless	Mirrored Bronze	Inside Window Dimensions	Outside Frame Dimensions
CF34	CF34B	CF34MS	CF34MB	3½" x 4¾"	4½" x 5¾"
CF46	CF46B	CF46MS	CF46MB	4" x 6"	5½" x 7½"
CF48	CF48B	CF48MS	CF48MB	4¼" x 8¼"	5¾" x 9¾"
CF69	CF69B	CF69MS	CF69MB	5⅝" x 8⅝"	7⅞" x 10⅞"
CF810	CF810B	CF810MS	CF810MB	7¾" x 9¾"	9¼" x 11¼"
CF8514	CF8519B	—	—	8½" x 14"	10" x 15½"



Part Number	Description
51CF001	Screws for certificate frames
51CF001W	Replacement Wrench

TELEPHONES & CABINETS

28

In this Section

ADA Phones, Building
& Line Powered

S3 Communicator
Grill Mount, Box Style,
Flush Mount 28.2

ADA Phones, Phone Line Powered

DL-3 Series
Black Box, Flush Mount,
Sub-Mount 28.3

K-Tech Sentry,
Fortress, Commander 28.4

Nautilus 28.5

Surecom Intercom 28.5

Line Loss Monitor 28.5

Replacement Parts & Accessories . 28.6

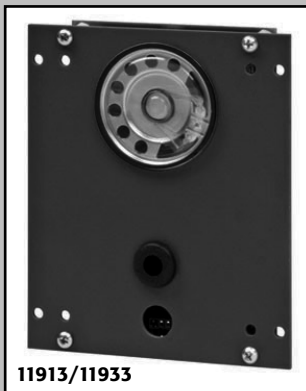

11913/11933



11910/11930



11912/11932



11911/11931

Part Number	Description	Dimensions	Power
11930	Red Painted Box Style	2" x 4" x 6"	Building
11931	#4 Stainless Steel	6½" x 10½"	Building
11932	#4 Stainless Steel	10" x 13¼"	Building
11933	Grill Mount		Building
11935	#4 Muntz	6½" x 10½"	Building
11936	#4 Muntz	10" x 13¼"	Building
11939	#4 Stainless Steel Box	2" x 4" x 8"	Building
11910	Red Painted Box Style	2" x 4" x 8"	Line
11911	#4 Stainless Steel	6½" x 10½"	Line
11912	#4 Stainless Steel	10" x 13¼"	Line
11913	Grill Mount		Line
11915	#4 Muntz	6½" x 10½"	Line
11916	#4 Muntz	10" x 13¼"	Line
11919	#4 Stainless Steel Box	2" x 4" x 8"	Line

ADA Phones Building & Line Powered

S3 Communicator Key Features

Line Sharing

Allows the sharing of a single telephone line between multiple S3 Communicators while retaining the ability to have each phone call its own number. Call into the group and isolate one phone or talk to the entire group.

Intercom/Phone combo

Allows the emergency phone and intercom to utilize the same set of phone lines. The S3 Communicator can also be configured to act primarily as an emergency telephone, but convert to an intercom to allow communication between the machine room and car.

Onboard Keypad for easy programming

Program the phone without being connected to a phone line. Once connected to a line, calls can be placed using the keypad and programming is made simple by one-touch buttons to access the programming menu.

Features	Key		
	Line	Building	Feature
Programmable volume control	•	•	
Digital message recording with excellent clarity	•	•	
Second set of push button contacts	•	•	
Auto answering	•	•	
Programmable with a 9V battery; no need for handset or telephone line	•	•	
Resetting fuses to protect phone	•	•	
Programming options via easy to understand voice prompts	•	•	
Continuous internal maintenance functions to check battery, telephone line and phone test reminder and trigger alarm upon failure		•	•
Remote diagnostics to check speaker and microphone functions		•	•
Shortcut program buttons available: SITE ID; PRG MENU; PH NO; VOLUME	•	•	•
Up to 3 outputs (dry contact) available	•	•	
Onboard keypad for programming and placing calls	•	•	•
Available in 1 or 2 LED versions	•	•	
Reset function for quick reset to factory defaults	•	•	
Programmable ring count	•	•	
Programmable call cancellation	•	•	
Battery backup: 4 hours minimum provided		•	
Programmable conversation time	•	•	
Line sharing up to 8 phones per telephone line		•	
Functions as ADA phone and intercom when used with our master station		•	•
Talk/End key has 2 functions:			
1. It allows the S3C to be used as a regular phone.			•
2. It provides onsite verification of an active phone line.			•

Questions? Answers at...
(866) CED-ELEV • (866) 233-3538
www.cedlevator.com

ADA Phones Phone Line Powered

DL-3 Series

DL-3 series phone is a micro-controller based emergency phone system that offers a wide range of features and system functions to meet your needs, and is **100% ADA compliant**.

The DL-3 is attractively designed and is available as either a flush-mount or a surface-mount version. Finish selections include stainless-steel, brass or chip-resistant powder coating. A vandal-proof version is also available.

Applications

The DL-3 is used in a wide range of elevator and other applications including parking garages, university campuses, shopping malls, airports, hospitals, and many more.

Functions & Features

- Two-number dialer
- User-recordable digital message for location identification.
- Voice prompted call handling instructions.
- PBX system compatibility
- Remote and local programming allows all system functions to be reprogrammed from central and local locations, including message recording.
- Tone dialing.
- Light flashes automatically when call is received.
- Auto-Answer mode allows incoming calls.
- 5-digit access code allows security against unauthorized reprogramming
- Auto disconnect
- Prank calls easily disconnected.
- Non-volatile memory circuits allow voice message, telephone number, and programmed information to be retained without any batteries or power for up to 10 years. That means no batteries to replace and no AC power needed!

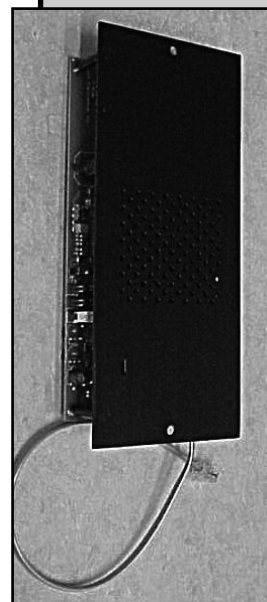
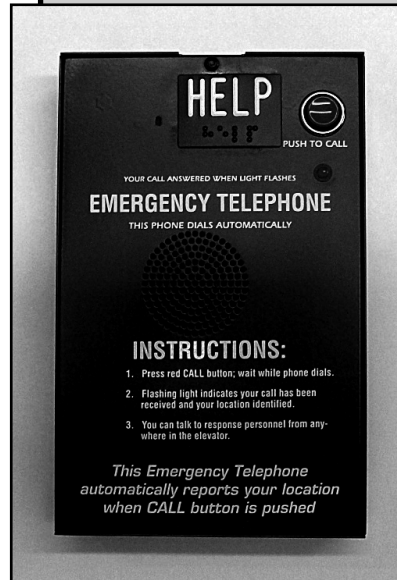

Part Number	Description	Dimensions
DL3BB	Black Box Phone, red push button, integrated braille. Stand alone unit for surface or phone cabinet mount.	5½"w x 8⅛"h x 1¾"d
FLUSHSSV	Flush Mount with Vandal Button Stainless steel plate, hands-free operation, integrated braille.	9"w x 12"h
DL3SM	Sub-Mount Phone (2-stud), for mounting inside the car operating panel where a 2-stud installation is required.	3¾"w x 8"h x 1⅜"d

Questions? Answers at...
(866) CED-ELEV • (866) 233-3538
www.cedlevator.com



ADA & NEW ELEVATOR CODE
COMPLIANT PHONES

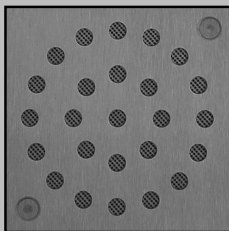

PROTECTIVE
SPEAKER SCREEN

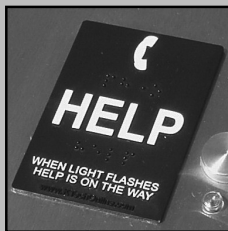

A17.1a-2002 ID
LABEL WITH BRAILLE



BUILT-IN
PROGRAMMING
KEYPAD



SENTRY, BOX OR
SURFACE MOUNT PHONE



FORTRESS,
FLUSH MOUNT PHONE

COMMANDER,
COP/GRILLE
MOUNT PHONE



ADA Phones Phone Line Powered

K-Phone ET401

Quick and easy installation
Two-wire hookup
Phone line powered

Features:

- Five-number automatic dialer
- Two voice announcement messages
- Call back capability
- Voice prompted programming steps
- Built-in keypad for on-site programming
- Remote programmable from any touch-tone phone
- Non-volatile memory
- Automatic shut-off
- Full ADA and A17 elevator code compliant
- FCC, IC and ETL approval

Specifications:

Wiring: 22 AWG shielded twisted pair
Phone line: Analog, 24-48 VDC line voltage
(30mA min.)
Power: Telephone line

Products are subject to change without prior notice.

Sentry, Box or Surface Mount

Fits most telephone boxes
Dimensions: 7½" h x 5" w x 2" d

Part#	Finish
ET401A-3	NEW brushed aluminum

Fortress, Flush Mount

Retrofit or replace phone box door
Dimensions: Faceplate: 12½" h x 10" w
Back box: 9⅝" h x 6½" w x 2½" d

Part#	Finish
ET1401A	Stainless

Custom sizes and finishes available.

Commander, COP/Fixture Grille Mount

Dimensions: 9½" h x 4¾" w x 1¾" d
(mount horizontally or vertically)

Part#	Configuration
ET401A-OEM-CM	Center Microphone

Custom sizes and configurations available.

Questions? Answers at...
(866) CED-ELEV • (866) 233-3538
www.cedlevator.com

ADA Phones

Nautilus

Available in both ET401 and 901
Sealed for ultimate weather protection
Ideal for outside lifts, pool and emergency phones

Phone kits - ET401 and ET901

Replace just the guts of phone
Replace discontinued phones
Update to latest code

SURECOM Machine Room Intercom - ET92A

Usually required over 60 ft rise - Check A17 code
Works with many manufacturers
Includes 1 Machine room handset phone (ET105)
Can connect to lobby phone or fire jack

Line Loss Monitor - ET98A

Solution for SME A17.1/CSA B44-2016
Identify loss of Telephone Signal
Works with K-Tech ET901 phones
Available Hall Station (ET98-LD) for retrofit



Available Both In ET401 And ET901



ET92A



ET98A



ET93-LD



MO1SP004

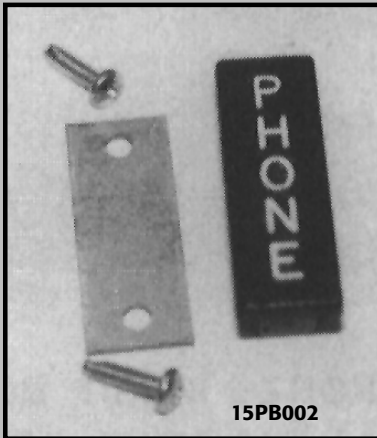

15PB002



HO2PB001

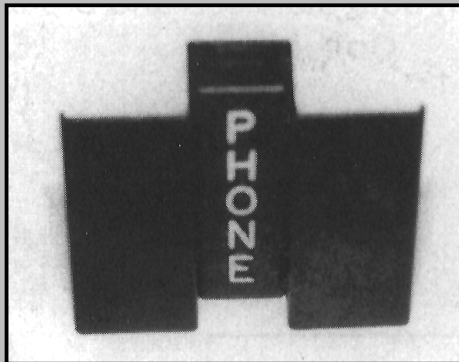

Phone Cabinet & Replacement Parts

Phone Cabinet Replacement Parts

Part Number	Description
M01SP004	Magnetic Catch
15PB002	Plastic Phone Box Handle, with screws, back plate, "PHONE" in raised, black letters
HO2PB001	Plastic Phone Box Handle "PHONE" in raised, black letters

ADA Phone Handle Adapter Plate

Part Number	Description
PHAS	Stainless
PHAB	Black
PHAR	Bronze

Phone Accessories

Part Number	Description
P06PE010	25' Telephone Cord
P06PE011	T-adapter
P06PE012	In-line phone adapter
SBJ325-PHONE	Adhesive braille plate with phone symbol
SBJ325-WORD	Adhesive braille plate with word "PHONE"

PHAB/PHAS

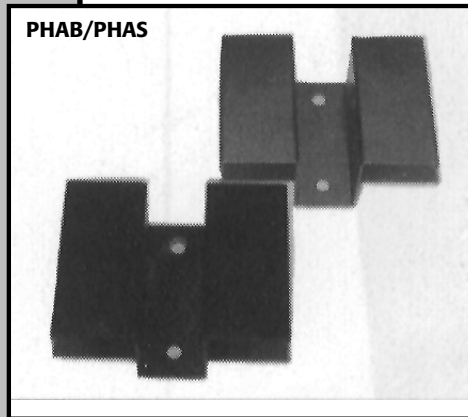

TEST & MEASURING EQUIPMENT

29

In This Section

Digital Multimeters

Fluke 87V and 83V 29.2

Fluke 77 IV 29.3

Fluke 336 Clamp Meter 29.3

Tachometers

LED Digital Contact 29.4

Hand 29.4

Replacement Wheel 29.4

Pressure Gauges

Door & Liquid Pressure 29.4

Rope Pressure 29.5

Rope Tension Gauge 29.5

Test Weight Cart 29.5

Lead Wire Seal Press & Wire . . . 29.5



Digital Multimeters

Fluke 87V and 83V Industrial Multimeters

Fluke 87V and 83V multimeters have measurement functions, troubleshooting features, resolution and accuracy to solve more problems on motor drives, in-plant automation, power distribution and electro-mechanical equipment.

Features

- Unique function for accurate voltage and frequency measurements on adjustable speed motor drives and electrically noisy equipment (87V).
- Large digit display with bright two-level backlight makes the 87V significantly easier to read.
- Measure 20A for up to 30 sec, 10A continuously.
- Optional magnetic hanger for easy setup and viewing while freeing your hands for other tasks (TPAK).
- Expanded capacitance range to 10,000 μ F.
- Built-in thermometer (87V).

Electrical Safety

All inputs are protected to CAT III 1000 V and CAT IV 600 V. They can withstand impulses in excess of 8,000V to help protect you from arc blast resulting from surges and spikes.

Features

Part Number:

True-rms AC voltage and current for accurate measurements on non-linear signals	•
Selectable filter for accurate voltage and frequency measurements on motor drives	•
0.05% DC accuracy	•
4½ digit mode for precise measurements	•
Built-in thermometer lets you carry one less tool	•
Large display digits and two-level bright white backlight for increase visibility	• •
10,000 μ F capacitance range for components and motor caps	• •
Peak capture to record transients as fast as 250 μ s	• •
Measure up to 1000V AC and DC; up to 10A, 20A for up to 30 seconds	• •
Auto and manual ranging for maximum flexibility	• •
Analog bargraph	• •
Frequency to 200kHz and % duty cycle	• •
Min/Max and average recording to capture variations automatically	• •
Relative mode to remove test lead resistance from low ohms measurements	• •
Access door for fast battery changes without breaking the calibration seal	• •
Limited lifetime warranty	• •

Functions	Range and Resolution	Basic Accuracy	
DC volts	600.0mV, 6.000V, 60.00V, 600.0V, 1000V	0.05%	0.1%
AC volts	600.0mV, 6.000V, 60.00V, 600.0V, 1000V	0.7% (true-rms)	0.5%
DC current	600.0 μ A, 6000 μ A, 600.0mA, 6.000A, 10.00A	0.2%	0.4%
AC current	600.0 μ A, 6000 μ A, 600.0mA, 6.000A, 10.00A	1.0% (true-rms)	1.2%
Temperature (excl. probe)	-200°C to 1090°C (-328°F to 1994°F)	1.0%	
80BK Temperature Probe	-40°C to 260°C (-40°F to 500°F)	2.2° or 2%	
Resistance	600.0 Ω , 6.000k Ω , 60.00k Ω , 600.0k Ω , 6.000M Ω , 50.00M Ω	0.2%	0.4%
Capacitance	10.00nF, 100.0nF, 1,000 μ F, 10.00 μ F, 100.0 μ F, 9,999 μ F	1.0%	1.0%
Frequency	199.99Hz, 1.9999kHz, 19.999kHz, 199.99kHz	0.005%	0.005%

Battery life: 400 hours typical with backlight off.
Size (LxWxD): 201mm x 98mm x 52mm (7.9in x 3.8in x 2in).
Weight: 355g (22oz).

Questions? Answers at...
 (866) CED-ELEV • (866) 233-3538
www.cedlevator.com

Digital Multimeters & Clamp Meter

Fluke 77 IV Digital Multimeter

The 77 IV Digital Multimeter has the features needed to repair most electrical and electronic problems. This meter is simple to use and has significant improvements over Fluke's original 70 Series with more measurement functions, conformance to the latest safety standards, and a much larger display that's easier to view.

Features

- Large display
- Backlight for work in dim areas.
- Min/Max to record signal fluctuations.
- Free your hands with the optional TPAK magnetic hanger.
- Auto and manual ranging.

Measures

- Wide 1000V measurement range.
- Average responding AC measurements.
- 0.3% accuracy.
- Frequency and capacitance.
- Resistance and continuity.

Fluke 336 Clamp Meter

- Inrush current feature
- Small body and jaws fit perfectly in your hand and into tight places.
- Controls positioned for one hand operation.
- Accurate low current measurements.
- Backlight; auto shut-off; display hold.
- Safety rating: IEC 1010-2-031, CAT III 600V
- Three-year warranty



Functions	Range	Best Accuracy	Best Resolution
DC volts	600.0mV to 1000V	± (0.3% + 1)	0.1mV
AC volts	6.000V to 1000V	± (2.0% + 2)	1.0mV
DC current	60.00mA to 10A	± (1.5% + 2)	0.01mA
AC current	60.00mA to 10A	± (2.5% + 2)	0.01mA
Resistance	600.0Ω to 50MΩ	± (0.5% + 1)	0.4%
Capacitance	1nF to 9,999μF	± (1.2% + 2)	1nF
Frequency	99.99Hz to 99.99kHz	± (0.1% + 1)	0.01Hz

(@23°C ± 5°C RH 0 to 90%)			
	Range	Accuracy	AC Response
DC volts	to 600.0V	1% + 5 counts	
AC volts	to 600.0V	1% + 5 counts (20 to 100Hz)	True-rms
DC current	0 to 600.0A	2% + 3 counts	
AC current	to 600.0V	2% + 3 counts (10 to 100Hz)	True-rms
Ohms	600.0Ω/6000Ω	1.5% + 5 counts	

Inrush: 100mS **Continuity:** ≤30Ω
Weight: 0.31kg (11oz). **Max wire dia:** 3cm (1.2in).
Size: (LxWxD): 201mm x 7.9cm x 4cm (9.9in x 3.1in x 1.6in).



Questions? Answers at...
 (866) CED-ELEV • (866) 233-3538
www.cedelevator.com

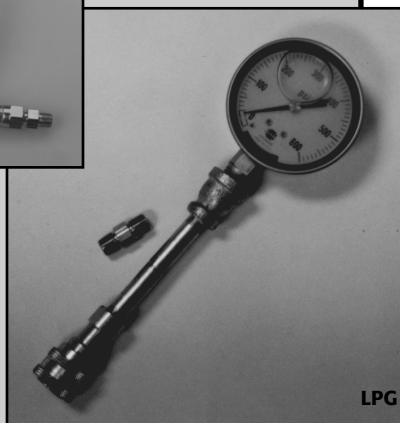
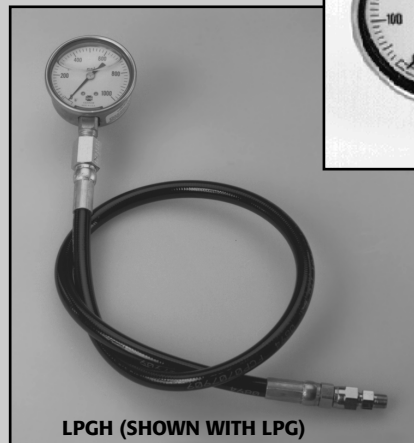
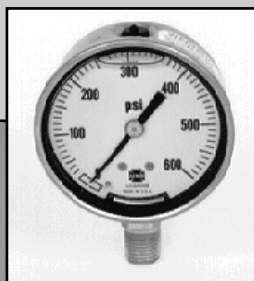

Tachometers & Pressure Gauges

LED Digital Contact Tachometer

A very versatile, very accurate LED digital contact tachometer, capable of reading from 0.1 to 25,000 revolutions, feet, meters, yards and inches, all per minute, second, or hour (including miles per hour). It has a seven reading memory and overspeed protection.

Part Number

DT 207LR	Included accessories: 2 cones, 1 inverted cone, 2" wheel, 3½" extension wheel
FPM-6	Replacement wheel 6" circumference
FPM-12	12" Wheel for OT Series

Hand Tachometers

Part Number DHT

- Shock resistant case
- Tolerance $\pm 0.5\%$ of extreme scale value
- RPM 16–20,000, FPM 5–6,000

Tachometer Replacement Wheel

Part Number DHTW

Door Pressure Gauges

Used to set proper door closing pressure, and to check belt tensions, as on hydraulic elevator pumps or door operator drives. It is also useful in checking car balance.

Part Number Capacity

10700	0-35 lbs.
--------------	-----------

Liquid Pressure Gauges

For setting up relief valve settings on hydraulic valves.

Part Number Description

LPG	Maximum 600 P.S.I.
LPG-1	Maximum 1000 P.S.I.
LPGH	36" flexible hose with fittings, 2500 P.S.I.

- Replacement measuring wheel

Connectors

Part Number Description

P02LG001	Nipple 1/8" x 1-1/2"
P02G003	Connector Elbow ST90 1/8"
P02G005	H1-62 Quick Conn 1/8" Female Adapter
P026006	Conn H1-63 Quick Nipple 1/8"

Questions? Answers at...
 (866) CED-ELEV • (866) 233-3538
www.cedlevator.com

Rope Tension Gauge, Test Weight Cart, Lead Wire & Selector Tapes

Rope Tension Gauge

Easy to assemble, easy to use and accurate. Unequal rope tension adds wear and tear and shortens rope life. The rope tension gauge measures relative tension in ropes allowing you to adjust for equal tension. Kit includes: 1 chrome hook, 1 spreader with clamp, 1 chrome tube and 1 spring balance with hook and clamp.

Part Number **10-650**

Mobile Rope-Tension Measuring System

Patented measuring principle allows you to measure and set the optimum tension of each rope, quickly and easily (integrated software-wizard). Works with different rope types and diameters.

Part Number	Description
EPW-455100	Includes control and 4 rope load sensors
EPW-455600	Additional LSM1 load sensor

Test Weight Carts

Total weight of each unit is 500 lbs., consisting of a cart weighing 100 lbs., and 8 weights weighing 50 lbs. each. The wheels on the unit are 8" diameter rubber tires with roller bearings. Unit comes with a locking bar, padlock and 2 keys to prevent theft of the weights. Approximate dimensions: 8" deep x 26" wide x 42" high. Inside box dimensions: 7.25" deep x 20" wide x 18" high. Standard red primer, custom colors available.

Part Number	Description
500LBWC	500lbs., 8" wheels with weights
WHEEL	8" replacement wheel, weight 6lbs.

Lead Wire Seal Press & Lead Sealing Wire

Recalibrating governors? We have the lead and wire seals, along with the sealing press to lock-in and hold adjustments. The wire seals are 2 strand, 23 gauge, galvanized wire, 8" long with $\frac{3}{8}$ " diameter, 2 hole, lead seal. Other combinations of lead seals and wires are available.

The sealing pliers are made with special leverage jaws for added sealing force. This is applied through hardened cams for longer life. The $\frac{1}{2}$ " diameter, removable sealing dies can be provided with initials or numerals at a minimal cost.

Part Number	Description
13-900	lead wire seal press
13-901	100 count 8" lead sealing wire

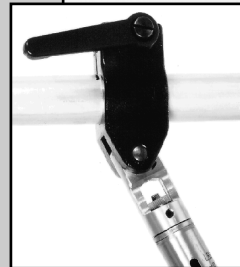
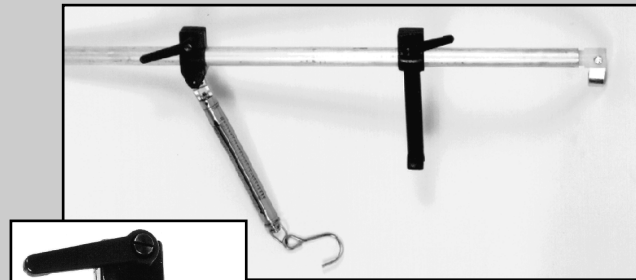

Questions? Answers at...
(866) CED-ELEV • (866) 233-3538
www.cedelevator.com

TOOLS

30

In this Section

Saw Blades, Arbors & Hole Saw Kits	30.2
Carbide Tipped Hole Cutters . . .	30.3
Drill Bits & Step Drill Bits	30.4
Drill/Tap Bits & Hand Taps	30.4
Snake Eye Driver Kit, Bits and Machine Screws . . .	30.6
Cable Cutters	30.7
Wire Strippers	30.8
Crimping Tools	30.9
Mod Plug Kit	30.9
CATV Connector Kit	30.9
Conduit Benders	30.10
Fish Tapes	30.10
Cable Oilers	30.11
Wicks	30.11
Calipers	30.11

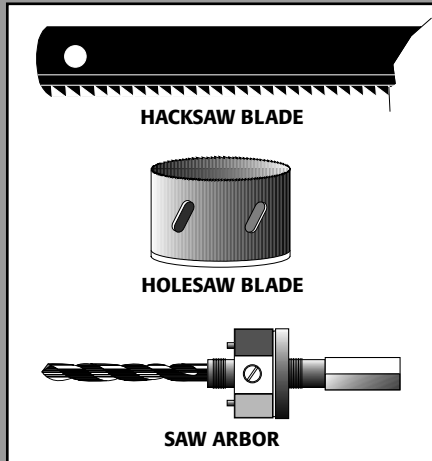

Saw Blades, Arbors Hole Saw Kits

Saw Blades & Arbors

Part Number	Size	Type	Standard Packaging
35272	12 in. x 24 teeth/in.	Hacksaw Blade	10
35273	12 in. x 32 teeth/in.	Hacksaw Blade	10
36091	1/4" hole	Saw Arbor	1
36092	3/8" hole	Saw Arbor	1
36072	44 7/8 x 1/2 x .020, 18 teeth/in.	Band Saw Blade	3

Reciprocating Saw Blades

Part Number	Size (Inches) L/W/TH	TPI	Blade			Application (Reciprocating Blade)
			Material	Bock	Qty.	
36043	6 x 3/4 x .035	18	Bi-metal	Straight	5	Long-Life blade for cutting structural steel, pipe, conduit, stainless steel, sheet metal (1/16-3/16" thick)
36044	8 x 3/4 x .035	18	Bi-metal	Straight	5	Long-Life blade for cutting structural steel, pipe, conduit, stainless steel, sheet metal (1/16-3/16" thick)
36055	4 x 3/4 x .035	18	Bi-metal	Straight	5	Structural steel, pipe, conduit, stainless steel: (1/16-3/16" thick) non-ferrous metal: (1/16-5/16" thick)
36056	6 x 3/4 x .035		Progressive	Bimetal	5	Long-life progressive blade for all metal, non-ferrous metal, sheet metal, pipe and other metal materials
36057	6 x 3/4 x .035	18	Bi-metal	Straight	5	Structural steel, pipe, conduit, stainless steel: (1/16-3/16" thick) non-ferrous metal: (1/16-5/16" thick)
36058	6 x 3/4 x .035	24	Bi-metal	Straight	5	All metal less than 1/8" thick: Tubing conduit, trim
36065	6 x 3/4 x .050	6	Bi-metal	Taper	5	Fast cutting, roughing-in work, nail-embedded wood, remodeling
36066	9 x 3/4 x .050	6	Bi-metal	Taper	5	Fast cutting, roughing-in work, nail-embedded wood, remodeling



Hole Saw Kit

- 8-piece kit includes hole saws and arbors for electrical sizes for pipe and conduit through 2 in.
- Durable plastic carrying case
- Includes arbors 35393 and 35394.

Hole Saws & Kits

Part Number	Size	Type	Standard Packaging*
38500	7/8, 1 1/8, 1 3/8, 1 3/4, 2, 2 1/2"	Hole Saw Kit	1
35345	7/8"	Hole saw	1
35347	1"	Hole saw	1
36520	1 1/8"	Hole saw	1
36524	1 3/8"	Hole saw	1
36530	1 3/4"	Hole saw	1
36533	2"	Hole saw	1
35367	2 3/8"	Hole saw	1
35368	2 1/2"	Hole saw	1
36544	3"	Hole saw	1
35375	3 1/4"	Hole saw	1
35377	3 1/2"	Hole saw	1
35378	3 3/8"	Hole saw	1
35382	4 1/8"	Hole saw	1
36556	4 1/2"	Hole saw	1

Questions? Answers at...

(866) CED-ELEV • (866) 233-3538
www.cedlevator.com

Carbide-Tipped Hole Cutters & Kits

TKO™ Carbide-Tipped Hole Cutters

The most efficient and clean cutter replacement for traditional knockouts, by making smooth holes in a fraction of the time at a fraction of the cost. Specifically designed to cut sheet metal, TKO cutters will even cut stainless steel with fine grained, carbide tips. The innovative design includes the exclusive SmoothStart™ replaceable pilot drill, which guides the cutter to the surface, avoiding cutter damage and providing smoother holes. An integral overdrill flange prevents cutter penetration beyond the sheet metal. When it comes to quality, performance and durability, IDEAL is the professional's choice for carbide-tipped hole cutters.

Part Number	Hole Size	Conduit & Pipe
36301	7/8"	1/2"
36302	1"	—
36303	1 1/8"	3/4"
36304	1 1/4"	—
36305	1 3/8"	1"
36306	1 7/16"	—
36307	1 1/2"	—
36308	1 3/4"	1 1/4"
36309	2"	1 1/2"
36310	2 1/2"	—



SmoothStart™ Replacement Pilot Drill

Part Number: **36312**

Guides cutter to surface, providing smoother holes and avoiding cutter damage.



Carbide Hole Cutter Kits

Part Number	Description
36311	4-Piece, includes 7/8", 1 1/8" & 1 3/8" bits SmoothStart™ replacement tip and carrying case
36314	6-Piece, includes 1/2", 3/4", 1", 1 1/4", 1 1/2" & 2" bits, and carrying case



Questions? Answers at...
(866) CED-ELEV • (866) 233-3538
www.cedelevator.com



Drill Bits & Step Drill Bits

Drill Bits

Part Number	Size	Type	Standard Packaging*
DRILL1/8	1/8"	Cobalt	1
DRILL1/4	1/4"	Cobalt	1
DRILL1/2	1/2"	Cobalt	1
DRILL10	#10	Cobalt	1
DRILL21	#21	Cobalt	1
DRILL27/64	27/64"	Cobalt	1
DRILL29	#29	Cobalt	1
DRILL3/8	3/8"	Cobalt	1
DRILL5/16	5/16"	Cobalt	1
DRILL5/32	5/32"	Cobalt	1
DRILL6	#6	Cobalt	1
DRILL7	#7	Cobalt	1
DRILL7/10	7/10"	Cobalt	1
DRILL7/32	7/32"	Cobalt	1
DRILL8	#8	Cobalt	1
DRILL9/64	9/64"	Cobalt	1
DRILLF	#F	Cobalt	1

Step Drill Bits

Part Number	Drill Diam. (Inches)	Number of Hole Sizes	Step Increments (Inches)	Step Thickness (inches)	Shank Dia. (Inches)
35511	1/8-1/2	13	1/32	1/8	1/4
35512	1/4-3/4	9	1/16	1/8	3/8
35513	1/4-7/8	11	1/16	1/16	3/8
35514*	1/2-1	8	1/16	1/8	3/8
35515	1/4-1 1/8	16	1/16	1/16	3/8
35516	3/16-1/2	6	1/16	3/8	1/4
35517	1/4-1 3/8	10	1/32	1/16-1/4	3/8

All shanks are 1 in. length.

*Requires pilot holes.

Electrician's Step Bit Kit

Part Number **35520**

- Durable blow-molded case
- Kit includes four step bits: (1/8-1/2, 1/4-7/8, 1/4-1 1/8, 1/4-1 3/8) —a solution for every electrical hole size 1/8-1 3/8 in.

Part Number **35524**

- Kit includes 3 Piece black oxide drill bits

Drill/Tap Bits Hand Taps

Drill/Tap Bits

- Complete hole drilling, tapping and deburring/countersinking in one operation with power drill saves labor and time.
- Back tapered beyond tap to prevent thread damage from over-drilling.
- Deburr/countersink also provided on bit beyond back taper.
- Made from hardened high-speed steel vs. carbon steel for longer life.
- High quality hex shank to ensure strong connection to drill chuck.
- Designed to tap up to 10-gauge metal.
- Quick change adaptor included in both metric and standard kits.

Part Number	Description
DTAPKITM	M3-M10 6-Piece Drill/Tap Set
DTAPKIT	6-32 to 1/4-20 6-piece Drill/Tap Set

Part Number	Description	DTAPkit	DTAPkitM
DTAP6-32	6-32NC Drill/Tap Bit	•	
DTAP8-32	8-32NC Drill/Tap Bit	•	
DTAP10-24	10-24NC Drill/Tap Bit	•	
DTAP10-32	10-32NF Drill/Tap Bit	•	
DTAP12-24	12-24NC Drill/Tap Bit	•	
DTAP1/4-20	1/4-20NC Drill/Tap Bit	•	
DTAP5/16-18	5/16-18NC Drill/Tap Bit		•
DTAP3/8-16	3/8-16NC Drill/Tap Bit		•
DTAPM3C	M3 x .50 Drill/Tap Bit		•
DTAPM4C	M4 x .70 Drill/Tap Bit		•
DTAPM5C	M5 x .80 Drill/Tap Bit		•
DTAPM6C	M6 x 1.00 Drill/Tap Bit		•
DTAPM8C	M8 x 1.25 Drill/Tap Bit		•
DTAPM10C	M10 x 1.50 Drill/Tap Bit		•

Specifications:

Material thickness	Up to 10 gauge
Material type	Mild steel, copper, brass, aluminum
Shank	1/4" quick change hex
Drill material	High-speed steel
Drill point	Split point with web thinning

Hand Taps

- **Taper Style:** Starts the thread square with workpiece.
- **Bottoming Style:** Generates the thread to the bottom.

Part Number	Size	Tap Style
BTAP1/4	1/4"	Bottoming
BTAP10/32	10/32"	Bottoming
BTAP5/16	5/16"	Bottoming
BTAP6/32	6/32"	Bottoming
BTAP8/32	8/32"	Bottoming
TTAP1/4	1/4"	Taper
TTAP1/2	1/2"	Taper
TTAP10/32	10/32"	Taper
TTAP3/8	3/8"	Taper
TTAP5/16	5/16"	Taper
TTAP6/32	6/32"	Taper
TTAP8/32	8/32"	Taper

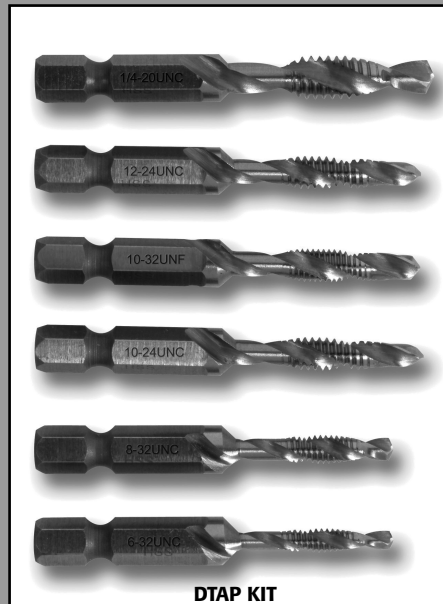

Questions? Answers at...
 (866) CED-ELEV • (866) 233-3538
 www.cedelevator.com

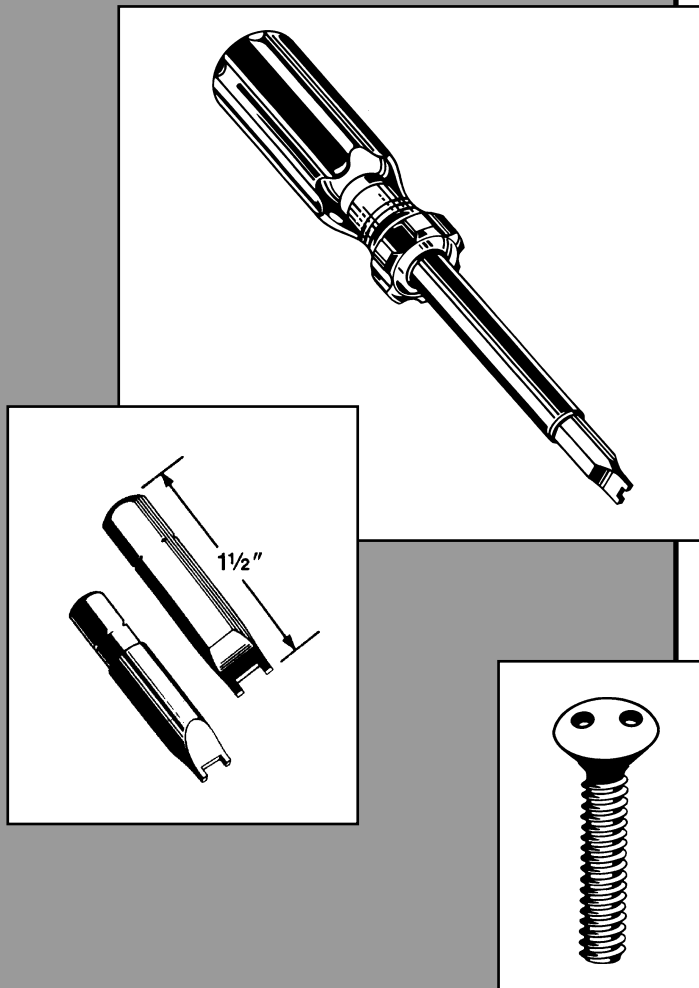

Snake Eye Driver, Bits & Screws

Snake Eye Spanner Driver Kit

The Spanner Driver Kit comes with 1 Magnetic Hand Driver and Spanner Bits (4, 6, 8, 10, 12, 1/4) in a convenient vinyl pouch. Spanner Screws also available. See Snake Eye Oval Head Machine Screws.

Part Number	Description
SP5.14	#SP5 Driver Kit with 5 Bits, 1/4" hex
SP5.516	#SP5 Driver Kit with 6 Bits, 5/16" hex

Snake Eye Spanner Bits

Please indicate size/hex shape when ordering.

Bit	1/4" Hex	5/16" Hex Size
	Part Number	Part Number
#4	1B.414	1B.4516
#6	1B.614	1B.6516
#8	1B.814	1B.8516
#10	1B.1014	1B.10516
#12	1B.1214	1B.12516
#1/4	1B.1414	1B.14516

Snake Eye Spanner Oval Head Machine Screws

These Snake Eye Spanner Oval Head Machine Screws have diameters of 10-32 and 10-24. They are made of stainless steel. Their lengths range from 1/2" to 2 in. Please specify size. Fit driver size #10. Other diameters available upon request.

Length	10-32 Diameter	10-24 Diameter
	Part Number	Part Number
3/8"		1.102380S
1/2"	1.103120S	1.102120S
5/8"	1.103580S	1.102580S
3/4"	1.103340S	1.102340S
1"	1.10310S	1.10210S
1 1/4"	1.1031140S	1.1021140S
1"	1.1031120S	1.1021120S
2"	1.10320S	1.10220S

Cable Cutters

Smart-Grip™ 9.5 inch Cable Cutter with Heavy-Duty Grips

Part Number **353052**

Features

- Drop-forged, high-carbon steel construction
- Precision-ground, hardened cutting edges provide accurate cuts without cable distortion
- Designed for maximum leverage with minimum effort
- Cuts 2/0 copper and 4/0 aluminum
- Smart-Grip™ handles are resistant to perspiration, water, oil and chemicals and provide a sure grip even when wet.
- Lifetime guarantee



Ratcheting Cable Cutter

Part Number **35056**

- Cuts hard drawn copper up to 400 KCMIL (MCM) and soft copper, aluminum and multiple conductor cable up to 600 KCMIL (MCM).
- Hardened steel blades ensure consistent cuts and long-term durability
- Rounded blade design minimizes cable distortion during cutting
- Quick release mechanism simplifies blade back-out
- Locking mechanism keeps handles closed for easy storage.
- Max. Jaw Opening: 1.375 in.
Not for cutting steel or ASCR.



Replacement blade

Part Number **35085** (moveable side only)

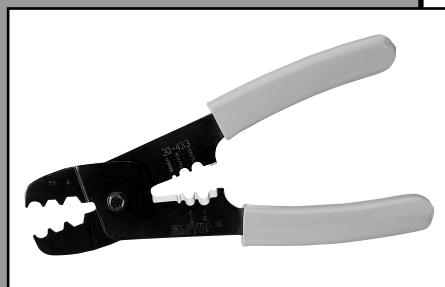
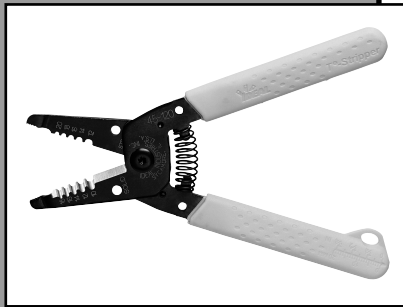

Wire Strippers

T-Stripper Wire Strippers

Features

- Form-ground, knife-type blades for accurate, easy stripping without nicking insulation
- Built-in wire cutter and looping holes
- Convenient plier nose for extra gripping strength
- Laser-etched wire gauge for easy-to-read visibility
- Spring-loaded automatic opening
- Corrosion resistant, black oxide finish
- Tough steel construction

Part Number	Description	Solid	Stranded
45120	T-5 T-Stripper	10-18	12-20

Reflex™ Super T-Stripper Wire Stripper

Features

- 6/32 and 8/32 self-chasing screw-cutting holes
- Locking pawl for safe storage
- Ergonomic design for maximum comfort
- Curved handles reduce wrist fatigue
- Sleeves extend forward to cushion thumb and fingers
- Textured sleeves with extra cushioning for added comfort

Part Number	Description	Solid	Stranded
45615	Reflex™ Super T Wire Stripper	8-16	10-18

Reflex™ Premium T-Stripper Wire Stripper

Features

- Ergonomic design for maximum comfort
- Curved handles reduce wrist fatigue
- Sleeves that extend to stripping head to cushion thumb and fingers
- Textured, no-slip sleeves provide a sure, easy grip

Part Number	Description	Solid	Stranded
45415	T-5 T-Stripper	10-18	12-20

Coax Strip & Crimp Tool

Part Number **30433**

Features

- Strips RG-59 and RG-6 coax cable
- Precision, form-ground stripping holes
- Durable blades cut copper-coated steel conductors
- Three crimping nests for crimping F-connectors and ring terminals
- Cushioned comfort-grip handles

Questions? Answers at...
 (866) CED-ELEV • (866) 233-3538
www.cedlevator.com

Crimping Tools

Smart-Grip™ Multi-Crimp Tool

Part Number **30-3429**

Features

Crimps bare or insulated terminals and splices on 10 to 22 AWG wire

9¾ in.

Knife-to-anvil blades never need resharpening

Excellent leverage for easy crimping and cutting

Drop-forged, high-carbon steel construction

Smart-Grip™ handles are resistant to perspiration, water, oil and chemicals and provides a sure grip even when wet

Lifetime guarantee



Economy Mod Plug Kit

Features

- Multi-function telephone/network tool, cuts, strips, and crimps
- Steel frame construction for durability
- Interchangeable dies allow for crimping RJ-45 and RJ-11 modular plugs
- Tool-less die change for added convenience
- Spring return handle for comfort
- Includes 10 each, RJ-11 and RJ-45 plugs

Part Number **33296**



F-Type (CATV) Connector Kit

For CATV terminations

Part Number **33400**

Part Number	Description (Kit Contents)	Quantity
30503	Crimpmaster CATV	1
85016	F-Connector, Crimp-on RG-59 Plug	20
85017	F-Connector, Crimp-on RG-6 Plug	20



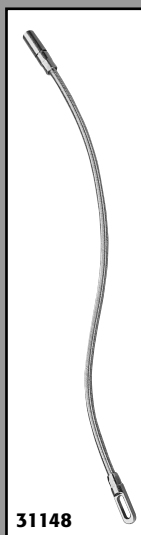

31148

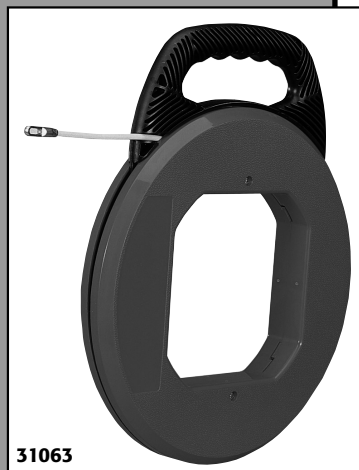

31063

Conduit Benders Fish Tapes

Conduit Benders

Ductile Iron Head & Handle Complete

Features

- Exceptional, durable materials for extra strength
- Reinforced at stress points for longer life
- Markings are raised and cast into the bender body on both sides for easy visibility
- Deeply serrated step helps prevent slippage when applying force
- Grooved internal hook surface helps prevent conduit from slipping
- Flat hook surface provides stable starting point
- Withstands a lifetime of heavy use
- Ductile iron material is stronger than malleable iron or aluminum

Part Number	Conduit Type & Size
74026	½" EMT
74027	¾" EMT; ½" Rigid; ½" IMC
74028	1" EMT; ¾" Rigid; ¾" IMC
74034	1¼" EMT; 1" Rigid; 1" IMC

Ideal Fish Tapes

Part Number	Description	End Type
31061	100ft. Fiberglass	Leader
31064	200ft. Fiberglass	Leader
31063	100ft. Fiberglass	Eyelet
31056	100ft. Nylon	Formed Hook
31057	240ft. Steel	Formed Hook
31148	Fish Tape Leader	

Cable Oilers, Wicks Calipers

Cable Oilers

Keeps cables lubricated for longer cable and sheave life. To determine size measure distance between outside cables and add 1" to each side.

Part Number	Description
C04	4" Oiler
C07	7" Oiler
C09	9" Oiler
C012	12" Oiler
C016	16" Oiler

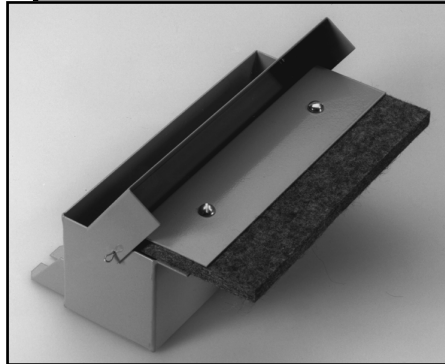

Wicks

Replacement wicks for cable oilers.

Part Number	Description
C04W	4" wick
C07W	7" wick
C09W	9" wick
C012W	12" wick
C016W	16" wick

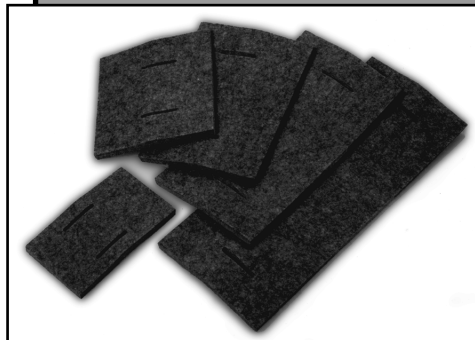

Calipers

Part Number **FJC10**

Firm Joint outside caliper legs made from high grade steel. Measure pistons up to 13" diameter.

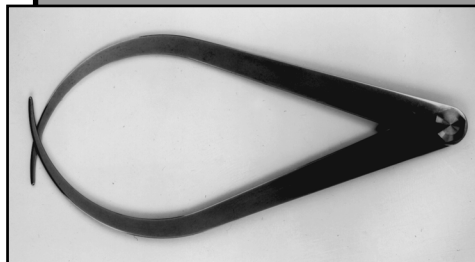

WIRE & WIRE ROPE PRODUCTS

31

In this Section

Elevator Wire Ropes	31.2-3
Wire Rope Tags	31.2
Power Cable:	
TEW and THHN Types	31.4
Door Lock Wire	31.5
Seizing Wire	31.6
Reeving Splices	31.6
Shortening Clamp	31.6
Wire Rope Grips	31.6
Roebing Clamp	31.7
Wire Rope Clips	31.7
Cable Bands	31.7
Wire Rope Cutters	31.8
Wire Rope Tension	
Measuring System	31.8
Wire Rope Diameter Gauges	31.8
Wedge Sockets	31.9
Babbit Sockets	31.9
Springs	31.9
Melting Pot & Accessories	31.9
Anti-Rotation Device	31.9
2:1 Rope Change Tooling	31.10

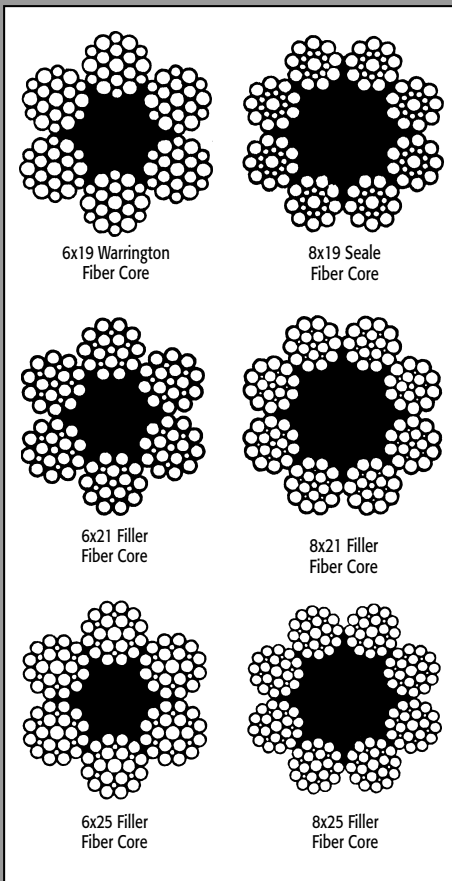

Traction Steel Wire Ropes — Fiber Core

Diameter Inches	6x19 Warrington, 6x25 Filler		8x19 Warrington, 8x19 Seale, 8x21 Filler, 8x25 Filler	
	Nominal Strength, lbs.	Weight lbs./ft.	Nominal Strength, lbs.	Weight lbs./ft.
3/8	8200	.23	8200	.20
7/16	11000	.31	11000	.28
1/2	14500	.40	14500	.36
9/16	18500	.51	18500	.46
5/8	23000	.63	23000	.57
11/16	27000	.76	27000	.69
3/4	32000	.90	32000	.82

* Right Regular Lay or Right Lang Lay available

Extra High Strength Wire Ropes — Fiber Core

Diameter Inches	6x19 Warrington, 6x25 Filler		8x19 Warrington, 8x19 Seale, 8x21 Filler, 8x25 Filler	
	Nominal Strength, lbs.	Weight lbs./ft.	Nominal Strength, lbs.	Weight lbs./ft.
3/8	11600	.23	9900	.20
7/16	15700	.31	13500	.28
1/2	20400	.40	17500	.36
9/16	25700	.51	22200	.46
5/8	31600	.63	27200	.57
11/16	38200	.76	32800	.69

* Larger sizes available upon request

Metric Rope

	Nominal Diameter (mm)	Approx Mass (lbs/100 ft.)	Min Breaking Force (Grade 1570/1770 N/mm ²) Lbs
commonly stocked	8	14.6	6920
commonly stocked	10	22.8	10800
avail upon request	11	27.6	13100
avail upon request	13	38.6	18300
avail upon request	16	58.5	27700
avail upon request	19	82.7	38900
avail upon request	22	111	52400

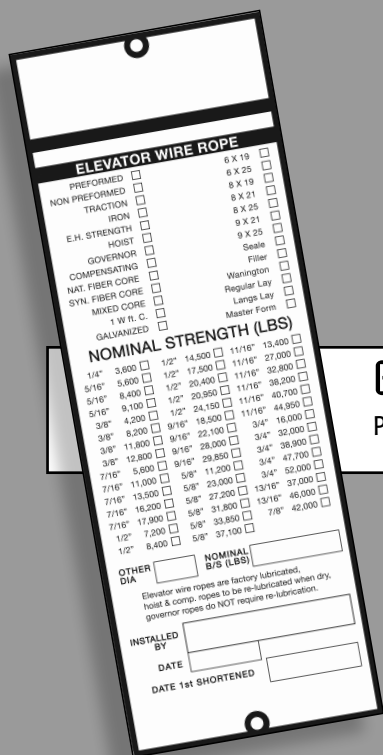

Generic Rope Tag
Part Number: BlankTag

Governor Wire Ropes — Iron

Diameter Inches	6x25 Filler		8x19 Warrington, 8x25 Filler	
	Nominal Strength, lbs.	Weight lbs./ft.	Nominal Strength, lbs.	Weight lbs./ft.
3/8	5000	.23	4200	.20
7/16	6400	.31	5600	.28
1/2	8400	.40	7200	.36
9/16	10600	.51	9200	.46
5/8	12800	.63	11200	.57

Questions? Answers at...
(866) CED-ELEV • (866) 233-3538
www.cedlevator.com

MasterForm™ Compacted Strand Rope

Fiber Core

Diameter Inches	8x19 Seale Weight lbs./ft.	Minimum Breaking Load (lbs)	
		Traction Grade	EHS Grade
3/8	.23	9850	10900
7/16	.31	13400	14900
1/2	.40	17500	19600
9/16	.50	22200	24900
5/8	.62	27400	30800
11/16	.75	33200	37300
3/4	.89	39500	44400
7/8	1.20	53800	60500
1	1.57	70300	79200

Messilot's MasterForm™ ropes answer the higher demands needed in applications where the conditions make it impractical to use regular ropes or ropes with steel core. MasterForm™ ropes are 8x19 Seale, right Lang lay ropes, but the strands are compacted during manufacture. This compacting process has many benefits:

- The minimum breaking load is much higher than a regular rope of the same diameter and grade. This means that in the elevator, the load on the rope will be lower as a percentage of the breaking load.
- The outer surface of the strands is smoother than in regular ropes and the surface area is larger. Larger surface area means **lower pressure and lower stresses in the wires**, resulting in **less wear of both rope and sheave**, and **greatly improved fatigue resistance**.

Seale Parallel Laid Rope — Steel Core

Diameter Inches	9x21 Filler Weight lbs./ft.	Minimum
		Breaking Load (lbs) EHS Grade
3/8	.261	13400
7/16	.354	18000
1/2	.461	24100
5/8	.718	39100

*Metric sizes available

The parallel closed steel core maximizes the metallic cross section and also improves the fatigue resistance of the rope because it reduces the internal contact pressure between the outer strands and the core. The breaking force is significantly higher than traditional constructions or combined core ropes. Used on traction drive elevators, especially on high rise installations, high speeds or where the ropes pass over many deflection sheaves. Parallel closed ropes are sensitive to externally induced torque.

During installation care should be taken to avoid twisting the ropes or letting the ropes untwist under their own weight while they hang freely.

Messilot Rope has a yellow stripe running the length of the rope. This should be used to determine if rope was twisted during installation.

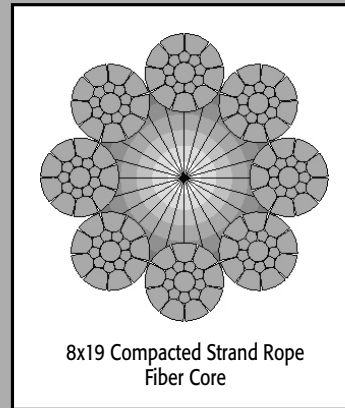

Rope Lay Terminology—Wire Direction

Right Lang Lay (RLL)

- Strands turn to the right
- Wires run in the same direction as strands
- Higher metallic surface area and flexibility
- Ideal for basement and side mount traction systems
- Hoist ropes

Right Regular Lay (RRL)

- Strands turn to the right
- Wires run down the rope opposite to strands
- Hoist, Compensating and Governor ropes

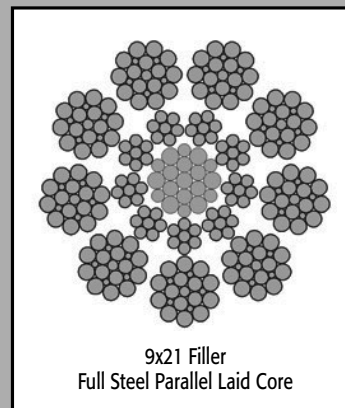
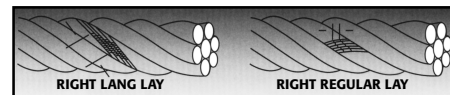

Power Cable TEW Type & THHN Type

Power Cable Single Conductor, TEW Type — 600 Volt/105°C Rated

Part Number	Description/Size of Single Conductor	Nominal OD inches • mm	Net Weight lbs/kft • kg/km	Current Rating	Put-ups	Jacket Colors (abbrv. below)
18 AWG TEW	16/.01" strand copper • 18 AWG	.11 • 2.79	8 • 12	6 amps	500'	all (see below)
16 AWG TEW	26/.01" strand copper • 16 AWG	.123 • 3.12	11 • 16	8 amps	500'	all
14 AWG TEW	41/.01" strand copper • 14 AWG	.132 • 3.35	18 • 27	15 amps	500'	all
12 AWG TEW	19/.01" strand copper • 12 AWG	.151 • 3.84	25 • 37	20 amps	500'	all

Jacket Colors			
BL=black	BR=brown	BU=blue	
GN=green	GY=grey	RD=red	MR=maroon
PK=pink	PU=purple	TN=tan	WH=white
			YW=yellow

Power Cable Single Conductor, THHN Type — 600 Volt/90°C Rated

Part Number	Description/Size of Single Conductor	Nominal OD inches • mm	Net Weight lbs/kft • kg/km	Current Rating	Insulation Thickness	Jacket Colors (abbrv. below)
4/0 THHN	19 strand. copper 4/0 AWG • 108 mm ²	.63 • 16.0	711 • 1058	260 amps	.05 inches	BL
3/0 THHN	19 strand. copper 3/0 AWG • 84.9 mm ²	.57 • 14.5	570 • 848	225 amps	.05 inches	BL
2/0 THHN	19 strand. copper 2/0 AWG • 67.5 mm ²	.52 • 13.2	458 • 681	195 amps	.05 inches	BL
1/0 THHN	19 strand. copper 1/0 AWG • 53.4 mm ²	.48 • 12.2	369 • 549	170 amps	.05 inches	BL
1 AWG THHN	19 strand. copper 1 AWG • 42.5 mm ²	.44 • 11.2	297 • 442	150 amps	.05 inches	BL
2 AWG THHN	19 strand. copper 2 AWG • 33.7 mm ²	.38 • 9.7	232 • 345	130 amps	.04 inches	BL, GN
4 AWG THHN	19 strand. copper 4 AWG • 21.2 mm ²	.32 • 8.1	151 • 225	95 amps	.04 inches	BL, GN
6 AWG THHN*	19 strand. copper 6 AWG • 13.3 mm ²	.25 • 6.4	94 • 140	75 amps	.03 inches	BL, GN, BU RD, WH
8 AWG THHN*	19 strand. copper 8 AWG • 8.3 mm ²	.21 • 5.3	62 • 92	55 amps	.03 inches	BL, GN, BU OR, RD, WH
10 AWG THHN*	19 strand. copper 10 AWG • 5.2 mm ²	.16 • 4.0	38 • 57	30 amps	.02 inches	all
12 AWG THHN*	19 strand. copper 12 AWG • 3.3 mm ²	.13 • 3.3	24 • 36	20 amps	.02 inches	all

Component Specifications

Stranded Conductors

Bare soft drawn copper complying with ANSI/ASTM B174 and ANSI/ASTM B3.

Jacketing

Nylon (polyamide) or its UL listed equivalent.

Jacket Colors

BL=black

GN=green

*6 AWG, 8 AWG, 10 AWG and 12 AWG are suitable for 105° C appliance wiring material (AWM). They also come in a variety of insulation colors and put-ups. See the last column (Jacket Colors) and the abbreviations below. When ordering, be sure to specify the insulation color and put-up you require.

All cables are cut to length. Please specify. (Except larger than 8 gauge)

MTW or THHN or THWN-2 conductors shall be UL Type "MTW or THHN or THWN-2," suitable for operations at 600 volts as specified in the National Electrical Code, at conductor temperatures not to exceed 75° C when exposed to oil or coolant, 90° C in wet or dry locations. Conductors shall be annealed copper, insulated with high-heat and moisture-resistant PVC, jacketed with abrasion, moisture, gasoline, and oil-resistant nylon or UL-listed equivalent.

Questions? Answers at...
(866) CED-ELEV • (866) 233-3538
www.cedlevator.com

Door Lock Wire

Door Lock Wire Single Conductor — 600 Volt/200°C Rated General Purpose SF-2, Hook-up, Hoistway Door, Interlock Wire

Part Number	Description/Size of Single Conductor	Nominal OD inches • mm	Net Weight lbs/kft • kg/km	Current Rating	Put-ups	Jacket Colors (abr. below)
18 ASF-2 Strand	7/.015" tinned copper 18 AWG • 0.8mm ²	0.13 • 3.3	12 • 17.9	6 amps	500, 1000'	BL & WH/RD

Component Specifications

Stranded Conductors

Bare soft drawn copper complying with ANSI/ASTM B174 and ANSI/ASTM B3.

Solid Conductors

Solid bare soft drawn copper complying with ANSI/ASTM B3.

Tinned Stranded Conductors

As above, with the copper conductor tinned for easier soldering.

Jacket Colors

BL=Black with Red Stripes

RD=Red

WH/RD=white/red

Clamps, Clips & Bands

Roebbling Clamp

Each of these clamps securely grab two ropes. Rope resists slipping through the clamp because of the spiral ridges cast into the grooves. Includes hardware shown.

Part Number	Size	Part Number	Size
16050	1/2"	16051	5/8"

Wire Rope Clips

Want to fasten two pieces of wire rope together with little or no damage to either rope, such as rigging for governor pull-thru tests? The combination bolt and saddle fist grip, make for easy assembly. For more permanent rigging use the familiar wire rope clips. Both style clips are forged steel with hot dipped galvanized finish and include standard full nut. Application data available upon request. Most popular sizes in stock.

A. Fist Grip Style:

Part Number	Size	Part Number	Size
16002	3/8"	16004	1/2"
16006	(5/8")	16008	3/4"
16000	5/16"		

B. Wire Rope Clips:

Part Number	Size	Part Number	Size
16012	(3/8")	16014	(1/2")
16016	(5/8")	16018	(3/4")

C. Double Wire Rope Clips:

Part Number	Size	Part Number	Size
16022	3/8"	16024	1/2"
16026	5/8"	16028	3/4"
16010	1/4"		

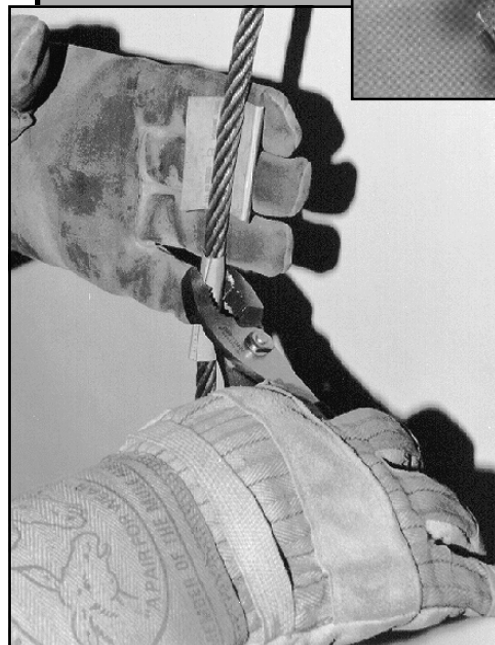
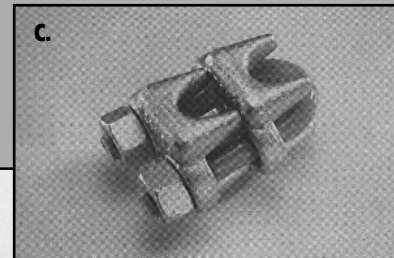
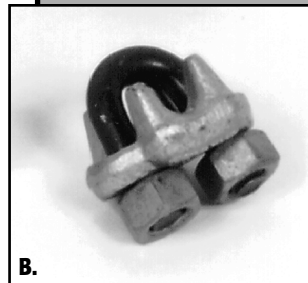
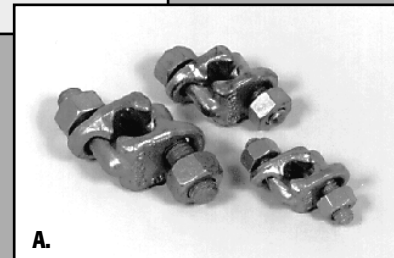

Cable Bands

Easier than double whipping cables with seizing wire. Bands are easily installed with pliers and prevent wire rope from fraying when being cut. Sized for all popular wire rope dimensions.

Part Number	Rope Size	Part Number	Rope Size
16201	1/4"	16202	3/8"
16203	1/2"	16204	5/8"
16205	3/4"	16206	7/8"
16207	1"	16208	1 1/4"

Questions? Answers at...
 (866) CED-ELEV • (866) 233-3538
www.cedlevator.com

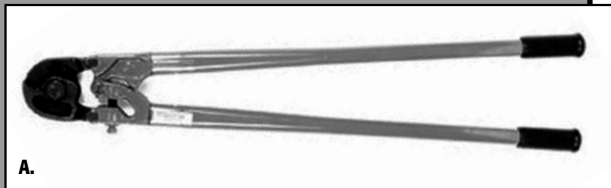

A.

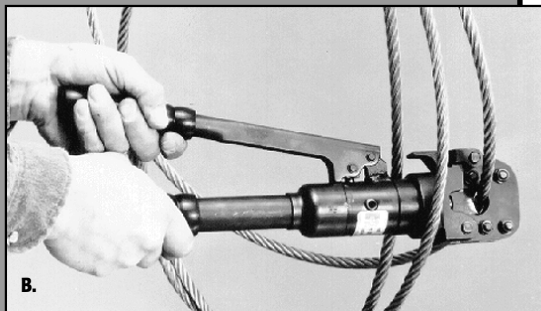

B.

Wire Rope Cutters, Gauges, Tension Measuring

Wire Rope Cutters

A. Manual Wire Rope Cutter

Part Number 16110 An excellent cutter for up to $\frac{3}{4}$ " wire rope. Its notched jaws and shearing action hold and cut with a minimum of distortion. Other cutters available for wire rope or electrical cable.

B. Huskie Wire Rope Cutter

Part JSH20 The modern, safe way to cut wire ropes. Hand-held, hand-pumped, hydraulic cutter with compact, lightweight, rugged design. Its 15" length makes it convenient to use on car tops and provides fast clean cuts, even through $\frac{3}{4}$ " wire rope. Replacement parts and repair service are available.

Part Number	Description
2007	Replacement Blade

Mobile Rope-Tension Measuring System

Patented measuring principle allows you to measure and set the optimum tension of each rope, quickly and easily (integrated software-wizard). Works with different rope types and diameters.

Part Number	Description
EPW455100	Includes control and 4 rope load sensors
EPW455600	Additional LSM1 load sensor

Wire Rope Gauges

Part Number WRG2000

The easy, no-hassle, foolproof way to check elevator wire rope for maximum reduced diameter. Designed for $\frac{3}{8}$ " $\frac{1}{2}$ " $\frac{9}{16}$ " and $\frac{5}{8}$ " diameter wire rope. No guess work, no mistakes, the gauge contact area of rope is from one lay to several strands, depending on rope diameter. Gauge stays parallel to rope, so you are always checking from the top of one strand to the top of the opposite strand for maximum reduced diameter. If rope fits into slot, it should be replaced.

Manufactured to ASME A17.1-1996 1001.2(C)(29)(C) specs of 2011 T3 aluminum, anodized red finish, acid etched numerals.

Part Number ATL001

Seven diameter markings are laser etched. Nominal diameter is marked on one side, ASME diameter reduction criteria for rope retirement marked on the other side. If gauge fits over rope, rope does not meet ASME requirements and should be inspected further. Available in Imperial scale for rope diameters from $\frac{3}{8}$ " through $\frac{1}{2}$ "



WRG-2000



ATL001

Questions? Answers at...

(866) CED-ELEV • (866) 233-3538
www.cedlevator.com

Wedge & Babbit Sockets, Springs, Melting Pot

Wedge Sockets

- Replace your old babbit sockets with wedge sockets. Save time, avoid fires, be safer, and avoid bad babbit pours when you're roping, or when you have to take the "stretch" out of your cable.
- Easy installation and adjustment
- Wedge sockets have been approved in all 50 states as well as the cities of Los Angeles, Chicago, and New York.
- Test for extra high tensile strength at 31,600lbs on 6x19 rope.

EMCO Part Number	Zippo Part Number	Dimensions	Rod Diam.	Rod Length
WS3812	ZZWNS10-12	3/8 x 18	1/2"	12"
WS3818	ZZWNS10-18	3/8 x 24	1/2"	18"
WS3824	ZZWNS10-24	3/8 x 30	1/2"	24"
WS1212	ZZWNS13-12	1/2 x 18	3/4"	12"
WS1218	ZZWNS13-18	1/2 x 24	3/4"	18"
WS1224	ZZWNS13-24	1/2 x 30	3/4"	24"
WS1230	ZZWNS13-30	1/2 x 36	3/4"	30"
WS1236	ZZWNS13-36	1/2 x 42	3/4"	36"
WS5812	ZZWNS16-12	5/8 x 18	3/4"	12"
WS5818	ZZWNS16-18	5/8 x 24	3/4"	18"
WS5824	ZZWNS16-24	5/8 x 30	3/4"	24"
WS5830	ZZWNS16-30	5/8 x 30	3/4"	30"
WS5836	ZZWNS16-36	5/8 x 42	3/4"	36"

* Clips and wedges can be ordered separately.

- Larger sizes of wedge sockets for heavy freight elevators, high-speed gearless, as well as for use with compensatory ropes are available upon request.

Governor Rope Wedge Sockets

For 1/2" and 3/8" rope.

Part Numbers **WS12GOV** and **WS38GOV**

Babbit Sockets & Babbits

Available, call for details.

Melting Pot & Accessories

This electric, high-quality cast iron melting pot with handle comes in 3 sizes, 15, 30, and 60 lbs. All melting pots have a variable thermostat that operates in the temperature range between 150-900 F. Melting pots operate on 110 VAC and come with a 6-foot power cord.

Part Number	Size	Part Number	Description
		16450	Babbitt 9.34 lb.
1605	30 lb.	16420	Ladle 3"
16410	60 lb.	16421	Ladle 6"

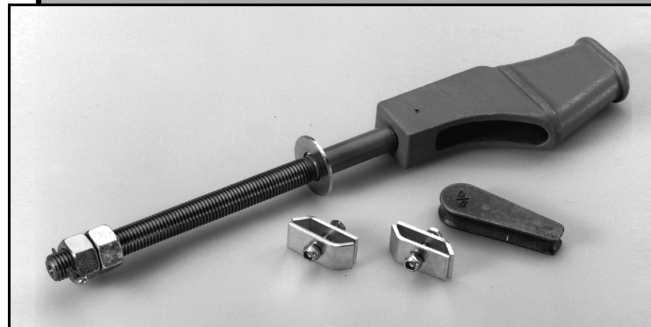

Springs

Part Number	Description	Dimensions		
		Length	O.D.	I.D.
SS900	For 1/2" rope	5"	1 13/16"	1 1/8"
SS1000	For 3/8" rope	4 3/4"	2 13/16"	1 1/8"
SS900A	Bushing assembly for both springs Includes 3 bushings, 3 washers			

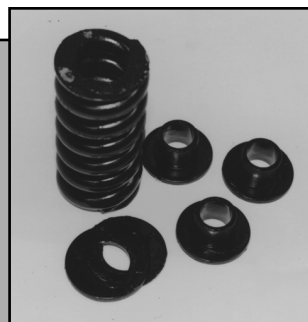

Anti-Rotation Device

The ARD is an innovative product that meets ANSI codes for restricting the rotation of suspension cables. The ARD is stronger and more reliable, yet safer and easier to install than current methods.

Part # **ARD-M20**

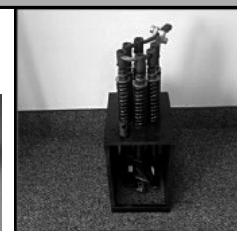

Questions? Answers at...
(866) CED-ELEV • (866) 233-3538
www.cedlevator.com

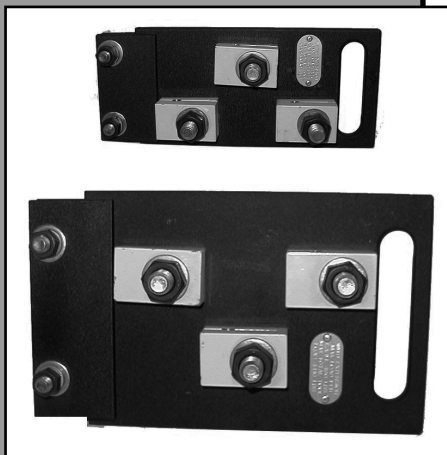
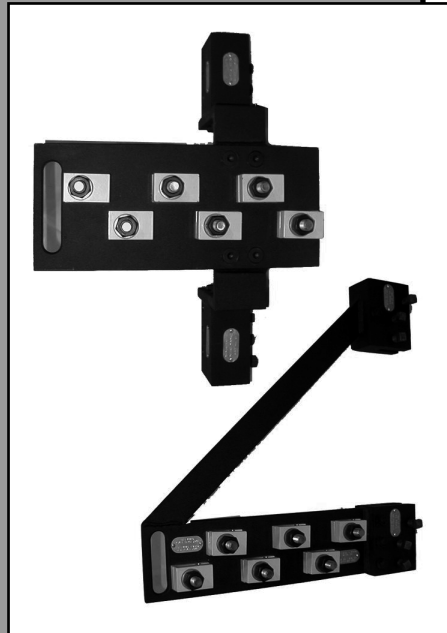

2:1 Rope Change Tooling

2:1 Rope Change Out Tool

This tool was designed specifically for 2:1 roping change out. You can easily eliminate excess labor costs by utilizing this patented, USA made tool. It is capable of safely and efficiently replacing up to 9 wire ropes (3/8" - 5/8"). You must add the extension brackets for all change outs from 7 to 9 ropes. For 2:1 rope change outs up to six (6) wire ropes you must specify the cable clip size. Each kit comes with complete installation instructions to guide you through the process of rope replacement.

Part Number	Description
16800	2:1 Rope Change Out Tool, Basic Kit (Includes 16-800-01 & 16-800-02)
16800-01	Replacement Live End Cable Support Bracket
16800-02	Replacement Dead End Cable Support Bracket
82660	'T' Handle Hex Drive

2:1 Color Coded Cable Clip Assembly

Part Number	Description
16800-03	3/8" Yellow Cable Clip Assembly (1) per cable, includes (2) 23203 Cap Screws
16800-04	1/2" Red Cable Clip Assembly (1) per cable, includes (2) 23203 Cap Screws
16800-05	5/8" Blue Cable Clip Assembly (1) per cable, includes (2) 23203 Cap Screws

2:1 Rope Change Out Tool Extension Kit

Designed specifically for 2:1 roping change out. By adding this extension kit to the basic kit, up to 9 wire ropes (3/8" to 5/8") can be replaced safely and efficiently.

Part Number	Description
16800-06	Replacement Live End Extension Bracket
16800-07	Replacement Dead End Extension Bracket
16800-08	Complete Kit, includes 16-800-06 & 16-800-07

Questions? Answers at...
 (866) CED-ELEV • (866) 233-3538
www.cedlevator.com

WIREWAY & FITTINGS

32

In this Section

Duct	32.2
Connector	32.2
Panel Connector	32.2
90° Elbow Assembly.....	32.3
Tee Assembly.....	32.3
Crossover Assembly	32.4
45° Elbow Assembly.....	32.4
End Cap/Reducer	32.5
Reducer	32.5
Insulated Bushing.....	32.5
Hatch Duct Mounting Kit	32.6
Wire Support Kit	32.6

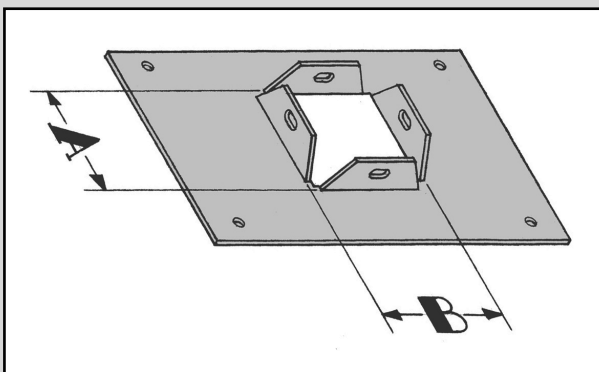
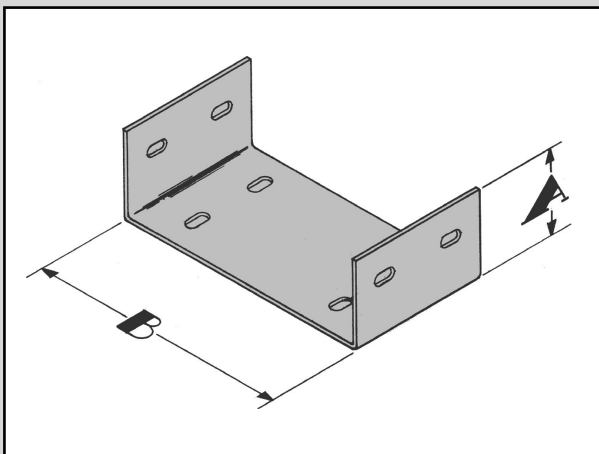
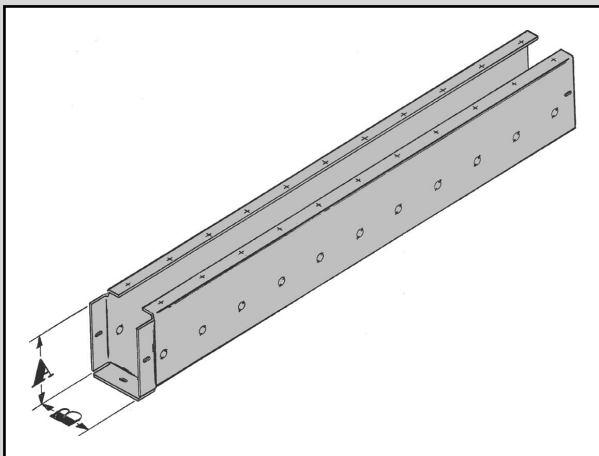

Duct, Connector & Panel Connector

Duct

Part Number	Dimensions Inches (A x B x 120)	Part Number	Dimensions Inches (A x B x 120)
DCV2525120	2½ x 2½ x 120	DCV258120	2½ x 8 x 120
DCV256120	2½ x 6 x 120	DCV2512120	2½ x 12 x 120
DCV2510120	2½ x 10 x 120	DCV44120	4 x 4 x 120
DCV46120	4 x 6 x 120	DCV48120	4 x 8 x 120
DCV410120	4 x 10 x 120	DCV412120	4 x 12 x 120
DCV254120	2½ x 4 x 120	DCV66120	6 x 6 x 120
DCV68120	6 x 8 x 120	DCV88120	8 x 8 x 120

- Two covers and hardware provided with each duct.
- Knockouts available on all duct except 6x6 and 8x8.

Connector/Splice

Part Number	Dimensions Inches (A x B)	Part Number	Dimensions Inches (A x B)
CON2525	2½ x 2½	CON25848	2½ x 8, 4 x 8
CON25646	2½ x 6, 4 x 6	CON2512412	2½ x 12, 4 x 12
CON2510410	2½ x 10, 4 x 10	CON66	6 x 6
CON68	6 x 8	CON88	8 x 8
CON25444	2½ x 4, 4 x 4		

- UL approved

Panel Connector/Flange

Part Number	Dimensions Inches (A x B)	Part Number	Dimensions Inches (A x B)
PCN2525	2½ x 2½	PCN258	2½ x 8
PCN256	2½ x 6	PCN2512	2½ x 12
PCN2510	2½ x 10	PCN44	4 x 4
PCN46	4 x 6	PCN48	4 x 8
PCN410	4 x 10	PCN412	4 x 12
PCN-8	6 x 8	PCN66	6 x 6
PCN254	2½ x 4	PCN88	8 x 8

- UL approved

Questions? Answers at...
 (866) CED-ELEV • (866) 233-3538
www.cedlevator.com

90° Elbow & Tee Assemblies

90° Elbow Assembly

Part Number	Dimensions Inches (A x B)	Part Number	Dimensions Inches (A x B)
L902525	2½ x 2½	L90254	2½ x 4
L90256	2½ x 6	L90258	2½ x 8
L902510	2½ x 10	L902512	2½ x 12
L9044	4 x 4	L90425	4 x 2½
L9048	4 x 8	L9046	4 x 6
L90412	4 x 12	L90410	4 x 10
L90625	6 x 2½	L9064	6 x 4
L9066	6 x 6	L9068	6 x 8
L90825	8 x 2½	L9084	8 x 4
L9086	8 x 6	L9088	8 x 8
L901025	10 x 2½	L90104	10 x 4
L901225	12 x 2½	L90124	12 x 4

• UL approved

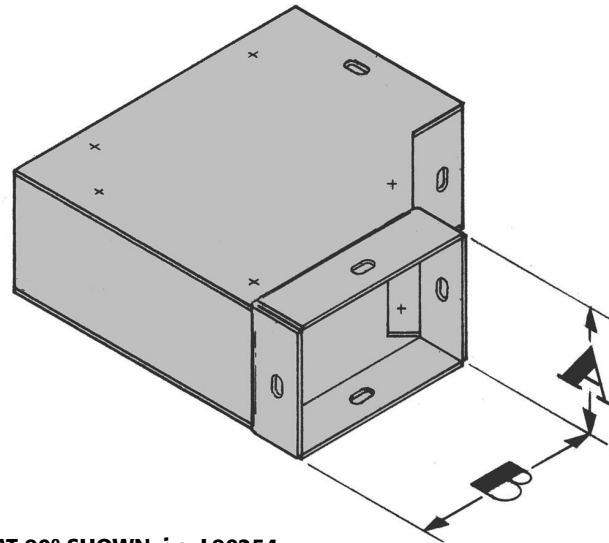

FLAT 90° SHOWN, i.e. L90254

Tee Assembly

Part Number	Dimensions Inches (A x B)	Part Number	Dimensions Inches (A x B)
TEE2525	2½ x 2½	TEE254	2½ x 4
TEE256	2½ x 6	TEE258	2½ x 8
TEE2510	2½ x 10	TEE2512	2½ x 12
TEE44	4 x 4	TEE425	4 x 2½
TEE48	4 x 8	TEE46	4 x 6
TEE412	4 x 12	TEE410	4 x 10
TEE625	6 x 2½	TEE64	6 x 4
TEE66	6 x 6	TEE68	6 x 8
TEE825	8 x 2½	TEE84	8 x 4
TEE86	8 x 6	TEE88	8 x 8
TEE1025	10 x 2½	TEE104	10 x 4
TEE1225	12 x 2½	TEE124	12 x 4

• UL approved

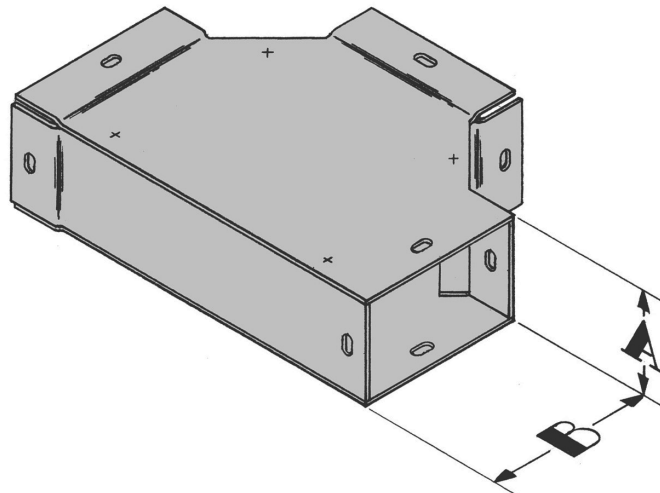

FLAT 90° SHOWN, i.e. TEE254

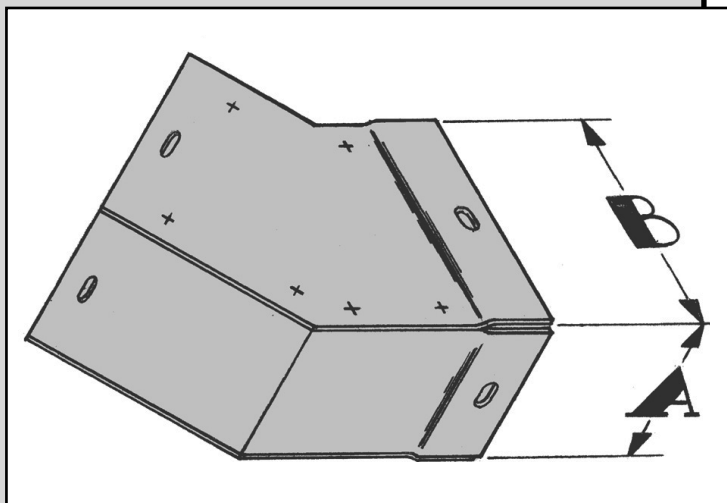
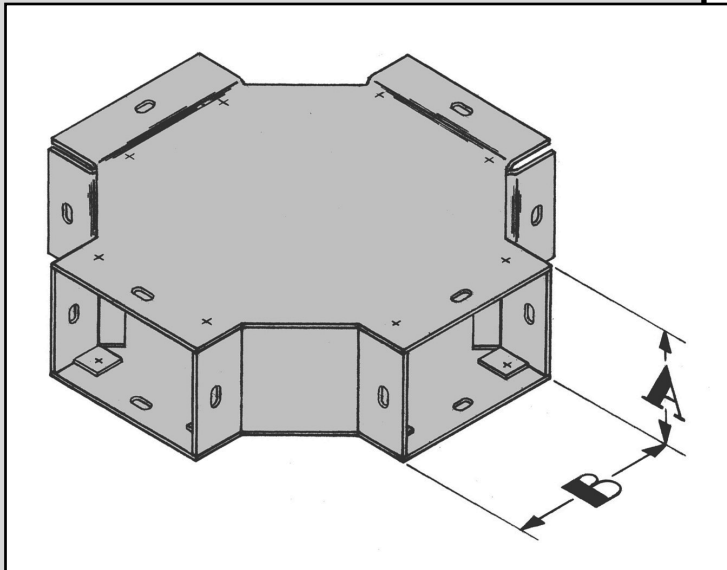

Crossover & 45° Elbow Assemblies

Crossover Assembly

Part Number	Dimensions Inches (A x B)	Part Number	Dimensions Inches (A x B)
CRS2525	2½ x 2½	CRS254	2½ x 4
CRS256	2½ x 6	CRS258	2½ x 8
CRS2510	2½ x 10	CRS2512	2½ x 12
CRS44	4 x 4	CRS425	4 x 2½
CRS48	4 x 8	CRS46	4 x 6
CRS412	4 x 12	CRS410	4 x 10
CRS625	6 x 2½	CRS64	6 x 4
CRS66	6 x 6	CRS68	6 x 8
CRS825	8 x 2½	TEE84	8 x 4
CRS86	8 x 6	CRS84	8 x 4
CRS1025	10 x 2½	CRS104	10 x 4
CRS1225	12 x 2½	CRS124	12 x 4

• UL approved

45° Elbow Assembly

Part Number	Dimensions Inches (A x B)	Part Number	Dimensions Inches (A x B)
L452525	2½ x 2½	L45254	2½ x 4
L45256	2½ x 6	L45258	2½ x 8
L452510	2½ x 10	L452512	2½ x 12
L4544	4 x 4	L45425	4 x 2½
L4548	4 x 8	L4546	4 x 6
L45412	4 x 12	L45410	4 x 10
L45625	6 x 2½	L4564	6 x 4
L4566	6 x 6	L4568	6 x 8
L45825	8 x 2½	L4584	8 x 4
L4586	8 x 6	L4588	8 x 8
L451025	10 x 2½	L45104	10 x 4
L451225	12 x 2½	L45124	12 x 4

• UL approved

Questions? Answers at...
 (866) CED-ELEV • (866) 233-3538
www.cedlevator.com

End Cap/Reducer Insulated Bushing

End Cap/Reducer

Part Number	Dimensions Inches (A x B)	Part Number	Dimensions Inches (A x B)
EPT2525	2½ x 2½	EPT254	2½ x 4
EPT256	2½ x 6	EPT258	2½ x 8
EPT2510	2½ x 10	EPT2512	2½ x 12
EPT44	4 x 4	EPT425	4 x 2½
EPT48	4 x 8	EPT46	4 x 6
EPT412	4 x 12	EPT410	4 x 10
EPT64	6 x 4	EPT625	6 x 2½
EPT68	6 x 8	EPT66	6 x 6
EPT84	8 x 4	EPT825	8 x 2½
EPT88	8 x 8	EPT86	8 x 6
EPT104	10 x 4	EPT1025	10 x 2½
EPT124	12 x 4	EPT1225	12 x 2½

• UL approved

Reducer

Part Number	Dimensions Inches (A x B-C x D)	Part Number	Dimensions Inches (A x B-C x D)
RDC256254	2½ x 6-2½ x 4	RDC44254	4 x 4-2½ x 4
RDC46254	4 x 6-2½ x 4	RDC4644	4 x 6-4 x 4
RDC48254	4 x 8-2½ x 4	RDC4844	4 x 8-4 x 4
RDC4846	4 x 8-4 x 6	RDC66254	6 x 6-2½ x 4
RDC6644	6 x 6-4 x 4	RDC6646	6 x 6-4 x 6
RDC8844	8 x 8-4 x 4		

• UL approved

Insulated Bushing

Part Number	Dimensions Inches (A x B)	Part Number	Dimensions Inches (A x B)
ISB2525	2½ x 2½	ISB258	2½ x 8
ISB256	2½ x 6	ISB2512	2½ x 12
ISB2510	2½ x 10	ISB44	4 x 4
ISB46	4 x 6	ISB48	4 x 8
ISB410	4 x 10	ISB412	4 x 12
ISB68	6 x 8	ISB66	6 x 6
ISB254	2½ x 4	ISB88	8 x 8

• UL approved

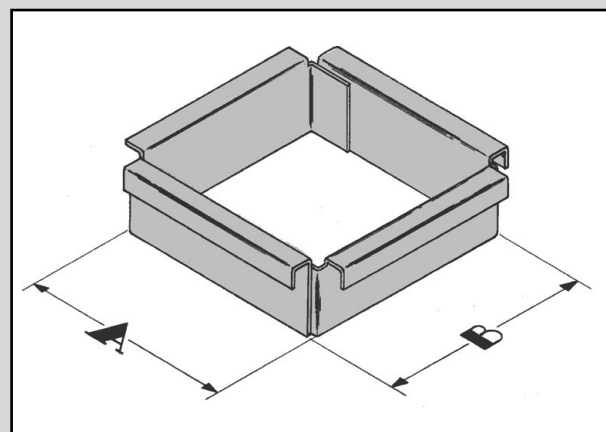
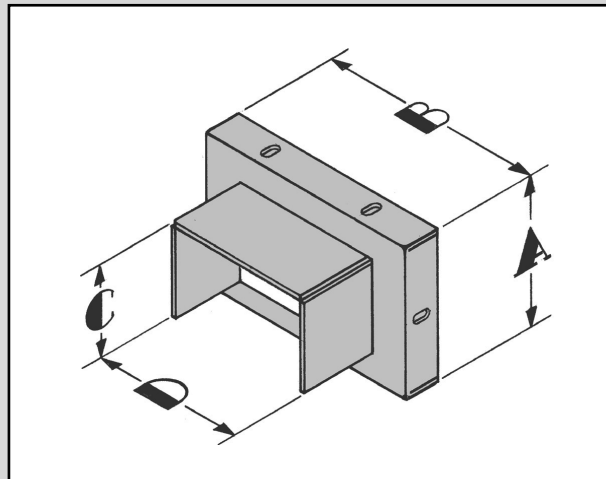
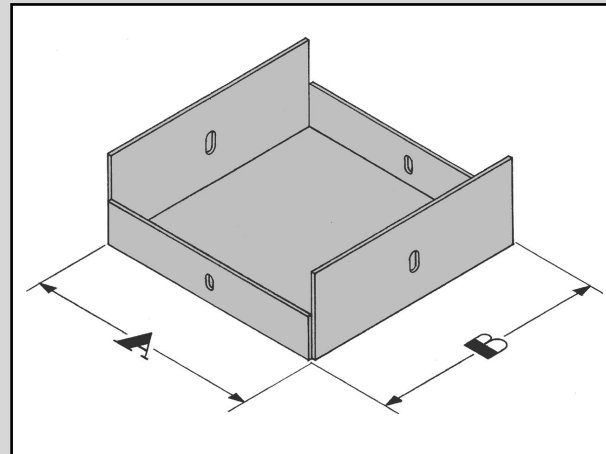

Questions? Answers at...
 (866) CED-ELEV • (866) 233-3538
www.cedelevator.com

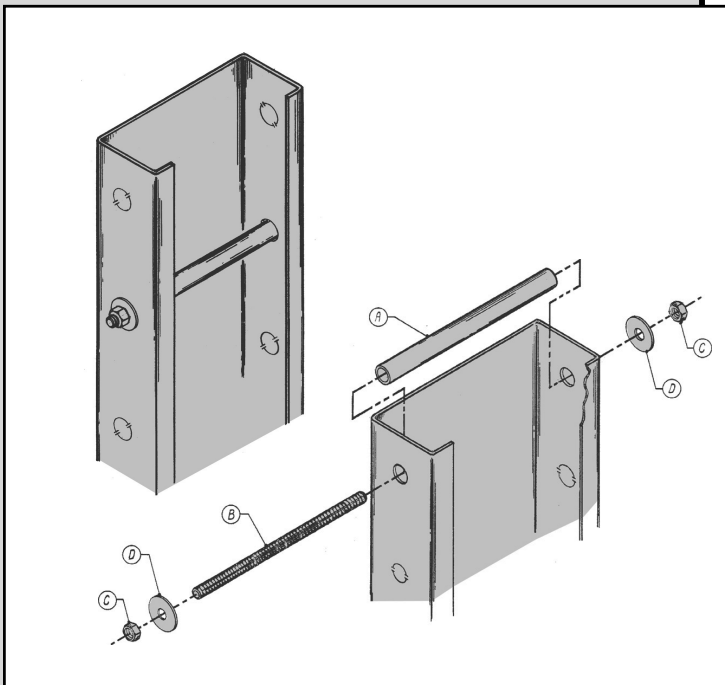
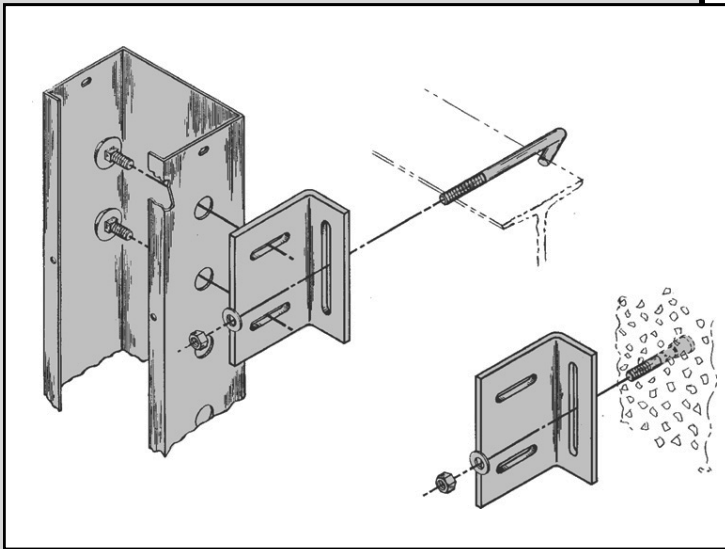

Wireway Accessories

Hatch Duct Mounting Kit

Part Number	Description
DMK3545-N	Divider Beam 3½-4½
DMK456-N	Divider Beam 4½-6
DMK100-25	Wall Mount 2½"
DMK100-04	Wall Mount 4", 6"

Wire Support Kit

Part Number	Description
WSK04-N	4"
WSK06-N	6"
WSK08-N	8"
WSK10-N	10"
WSK12-N	12"
WSK14-N	14"

Junction Boxes (with knockouts and terminals)

Part Number	Size inches	Depth & Capacity inches • wire count	Standard Packaging
JBX40	14 x 8½	3¼ • 40 wires	1
JBX80	24 x 8½	3¼ • 80 wires	1
JBX108	36 x 8½	3¼ • 108 wires	1

Junction Box Components

Part Number	Description	Standard Packaging*
0924	Terminal block	100
67	Zinc-plated track	3' lengths

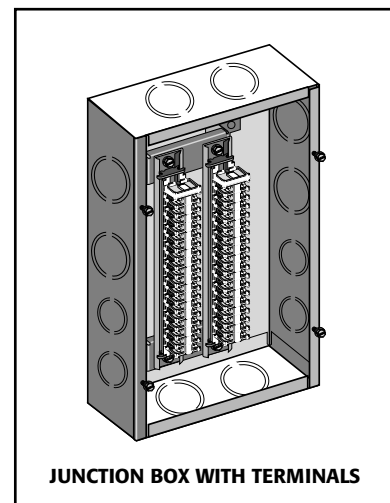

DATA & ORDER FORMS

33

In this Section

Stock SRH Engineering Data Form	33.2-4
ECC Fixture Order Form	33.5
Door Operating Equip Estimate/Order Form .	33.6
Replacement Door Form	33.7
Pump Unit Survey Form	33.8
Order Form	33.9-10
Quick Reference - Frequent Order Items .	33.11-12



(866) CED-ELEV
(866) 233-3538

Long Beach, CA • Grand Prairie, TX • Columbia, MD

STOCK SRH



Engineering Data Form – Page 1

160701

Warning: Review Before Submittal

- Failure to Provide Accurate and Complete Information could result in delay of stock SRH approval
- All Fixtures must be 24 VDC/6 Watts Max.

Table of Contents	
1. Job Information / General Controller Information	3. Landings and Openings / Car Door Data
2. Motor Data / Features & Functions	

This document can be edited, saved, and submitted electronically using Adobe Reader.

Job Details	
Job Name: <input type="text"/>	Market Segment:
PO #: <input type="text"/>	<input type="checkbox"/> Federal <input type="checkbox"/> Health Care <input type="checkbox"/> Financial
Job Location (City & State) <input type="text"/>	<input type="checkbox"/> Education <input type="checkbox"/> Hospitality <input type="checkbox"/> Residential
	<input type="checkbox"/> Other

Purchasers Information: (If packager fill in End User Info)	
Name: <input type="text"/>	
Title: <input type="text"/>	
Company: <input type="text"/>	
Phone: <input type="text"/>	Fax: <input type="text"/>
Cell: <input type="text"/>	
Email: <input type="text"/>	
Engineering Contact Information: (If different than above)	
Name: <input type="text"/>	
Phone: <input type="text"/>	Fax: <input type="text"/>
Cell: <input type="text"/>	
Email: <input type="text"/>	
<input type="text"/>	Date Filled Out

General Controller Information

ASME 17.1 Elevator Safety Code Compliance	
<input type="checkbox"/> 2016	Additional Local Code
<input type="checkbox"/> 2013	
<input type="checkbox"/> 2010	
<input type="checkbox"/> 2007	
<input type="checkbox"/> 2004	
<input type="checkbox"/> 2000	
<input type="checkbox"/> NYC (Appendix K)	
<input type="checkbox"/> No Fire Service	<input type="checkbox"/> MASSACHUSETTS

Configuration	
<input type="checkbox"/> Simplex	<input type="checkbox"/> # Cars
<input type="checkbox"/> Group	<input type="checkbox"/> # Cars in Group <input type="checkbox"/> # of Hall Risers/Group
	<input type="checkbox"/> Swing Riser, Car # <input type="text"/>
<input type="checkbox"/> Selective Collective (2 buttons/floor, multiple calls)	

Standard Features Provided	
<ul style="list-style-type: none"> • SmartConnect Package - (Pre-Wired) • Two board system (MR/COP) • Sprecher + Schuh (Soft Starter) • Independent Service • Prewired Fixtures available upon request 	<ul style="list-style-type: none"> • Hoistway Access

Electrical Main Line and Specification	
Main Line Specification:	
<input type="text"/>	Main Line Volts
<input type="checkbox"/>	Three Phase (ONLY)
<input type="checkbox"/>	Hz (Main Line is 60Hz unless stated otherwise)

Hydraulic Features, Motor, and Valve Data

Hydraulic Features (<input type="checkbox"/> Features for all cars is the same as car 1) Failure to provide complete data will result in delay of stock SRH approval					
Car	Contract Speed	Capacity	Battery Lowering	Low Pressure, Low Oil, and Oil temp are all included.	Viscosity Control
1			<input type="checkbox"/>		<input type="checkbox"/>
2			<input type="checkbox"/>		<input type="checkbox"/>
3			<input type="checkbox"/>		<input type="checkbox"/>
4			<input type="checkbox"/>		<input type="checkbox"/>

Motor & Valve Data (<input type="checkbox"/> Data for all cars is the same as car 1) Failure to provide complete data will result in delay of stock SRH approval									
Car	# Motor Leads	Motor Volts	FLA	HP	Valve Brand/Model	Valve Volts	# of Valves (1 Standard)	# of Coils (4 Standard)	Dual Jacks
1						Must be 110/115/120 vac			<input type="checkbox"/>
2						Must be 110/115/120 vac			<input type="checkbox"/>
3						Must be 110/115/120 vac			<input type="checkbox"/>
4						Must be 110/115/120 vac			<input type="checkbox"/>

FIXTURES (All Fixtures Must be 24 VDC/6 Watts Max)

In Car Position Indicator Not Required

CE Micro Com Discrete Signals (one line per floor)

DL-20 (interface only)

In Car Arrival Lantern Not Required

CE Micro Com Discrete Signals

Bulb/Chime wattage (if Discrete)

In Car Passing Chime Not Required

CE Micro Com Discrete Signal

Bulb/Chime wattage (if Discrete)

In Hall Position Indicator Not Required

CE Micro Com (default) Discrete Signals (one line per floor)

EX-51 (interface only)

of Floors with Hall Position Indicators

In Hall Arrival Lanterns Not Required

First Floor Only (Discrete) CE Micro Com Lanterns (Type: SA130M Req.)

All Floors (Smartrise Hall Boards)

EX-51/EX31 (interface only)

FEATURES

Emergency Power (if generator cannot run all cars) Not Required

E.P. Contact from Generator is
 Normally Open Normally Closed

Power Pre-Transfer Contact from Generator is
 Normally Open Normally Closed Not Present (default)

Emergency Power Car Selector Switch
 Single Car Selection Multiple Car Selection (provide details below) (default)

Number of cars the generator can operate simultaneously. (default value is 1 car)

Generator powers other Simplex/Groups.

Car Call Security (specify floors on page 3) Not Required

Using COP Floor Buttons as Code Entry

Using Dry Contacts from Card Readers and/or Keyswitches
 Inputs in Car Station (default) Inputs in Machine Room

Override Security When on Independent Service or Attendant Service

Provide a Car Call Security Override Input
 Input in Car Station (default) Input in Machine Room

Door Open Button Functions on Secured Landings

Other Considerations

Notes and Special Instructions:

Landings and Openings

Floor Information			Floor Openings		Car Call Security	
	Floor Label	Floor Height	Car 1	Car 2	Car 1	Car 2
	Overhead -> (default 13ft)		F R	F R	F R	F R
	15		<input type="checkbox"/>	<input type="checkbox"/>	<input type="checkbox"/>	<input type="checkbox"/>
	14		<input type="checkbox"/>	<input type="checkbox"/>	<input type="checkbox"/>	<input type="checkbox"/>
	13		<input type="checkbox"/>	<input type="checkbox"/>	<input type="checkbox"/>	<input type="checkbox"/>
	12		<input type="checkbox"/>	<input type="checkbox"/>	<input type="checkbox"/>	<input type="checkbox"/>
	11		<input type="checkbox"/>	<input type="checkbox"/>	<input type="checkbox"/>	<input type="checkbox"/>
	10		<input type="checkbox"/>	<input type="checkbox"/>	<input type="checkbox"/>	<input type="checkbox"/>
	9		<input type="checkbox"/>	<input type="checkbox"/>	<input type="checkbox"/>	<input type="checkbox"/>
	8		<input type="checkbox"/>	<input type="checkbox"/>	<input type="checkbox"/>	<input type="checkbox"/>
	7		<input type="checkbox"/>	<input type="checkbox"/>	<input type="checkbox"/>	<input type="checkbox"/>
	6		<input type="checkbox"/>	<input type="checkbox"/>	<input type="checkbox"/>	<input type="checkbox"/>
	5		<input type="checkbox"/>	<input type="checkbox"/>	<input type="checkbox"/>	<input type="checkbox"/>
	4		<input type="checkbox"/>	<input type="checkbox"/>	<input type="checkbox"/>	<input type="checkbox"/>
	3		<input type="checkbox"/>	<input type="checkbox"/>	<input type="checkbox"/>	<input type="checkbox"/>
	2		<input type="checkbox"/>	<input type="checkbox"/>	<input type="checkbox"/>	<input type="checkbox"/>
	1		<input type="checkbox"/>	<input type="checkbox"/>	<input type="checkbox"/>	<input type="checkbox"/>
	Default PI Labels	Pit -> (default 4ft)	Pit		Pit	

We will default to the lobby landing and the landing above for main and alternate fire floor respectively.

Main Fire/Lobby Floor
 Alt Fire Floor

Clearly Mark F/R Openings

Stock Controller Approved Door Interfaces

Use this door for all cars, or specify which cars use it

All	Car 1	Car 2
<input type="checkbox"/> F <input type="checkbox"/> R	<input type="checkbox"/> F <input type="checkbox"/> R	<input type="checkbox"/> F <input type="checkbox"/> R

- Armor** D3000
- ATS-2405** Direct
- DC-68** D3000
- HD68** D3000
- HD 73-Dover type D/IVO** D3000
- HD-85** D3000
- HD91** D3000
- HD-98 (Non encoder-based version only)** D3000
- HDLM** Direct
- KIS 100** Direct
- LD03 (DC Only)** D3000
- MOCT** D3000
- MOC-T2** D3000
- MOD (L,G,X)** D3000
- MOH** D3000
- MOM** D3000
- MOML** D3000
- MOVFE** Direct
- MOVFE 2** Direct
- MOVFR** Direct
- MOVFR 2** Direct
- MOXL (exp. proof)** D3000
- MOXR** D3000
- OTIS 6970** D3000
- OTIS 7770A** D3000
- OTIS 7782AA (DC Only)** D3000
- OTIS AAA 7782 AT** D3000
- OTIS AAA 7782 AT (DC Version)** D3000
- OTIS Type F** D3000
- VFE 2500** Direct
- Westinghouse HG d310** D3000
- Westinghouse HY** D3000

	Total Hoistway Height (ft)
Car 1	
Car 2	

* Stock controller supports rear openings, but does not support walk through applications.

All cars same as Car 1

Include Hall Network Cat5 package
 Controller (MR) to Hall Network (Hoist-way) Cat5 Cable Length

25 ft (default) 50 ft 100 ft

Notes and Special Instructions:

Door Protection

Photo Eye/Light Curtain (default) Mechanical Safety Edge Door Hold Button



Questions? Answers at...
(866) CED-ELEV • (866) 233-3538
www.cedelevator.com

ECC

FIXTURE ORDER FORM

DATE _____

COMPANY

JOB

NAME: _____

NAME: _____

ADDRESS: _____

ADDRESS: _____

CITY: _____

CITY: _____

STATE: _____ ZIP: _____

STATE: _____ ZIP: _____

CONTACT NAME: _____

PHONE: _____ EMAIL: _____

WILL CALL _____ OR SHIPPING ADDRESS: _____

- 1. CONTROLLER MANUFACTURER : _____
2. ELEVATOR QTY _____ : SIMPLEX _____ DUPLEX _____ OTHER _____
3. FLOOR MARKINGS: 1) _____ 2) _____ 3) _____ 4) _____ 5) _____ 6) _____ 7) _____ 8) _____ 9) _____ 10) _____
EGRESS FLOOR: _____ 2004 CODE: _____ 2010 CODE: _____ OTHER: _____ FIRE KEY# _____
4. MAIN C.O.P. HINGED ON: RIGHT _____ LEFT _____
AUXILIARY C.O.P. HINGED ON: RIGHT _____ LEFT _____ (IF APPLICABLE)
SWING RETURN MANUFACTURER _____ (IF APPLICABLE)
5. DL-20 LCD PI SERIAL LINK 7" _____ 10" _____ or CE PI: _____
6. SMOKING PLATE INFO: STATE _____ CITY _____ OTHER _____
SPECIAL WORDING REQUIRED _____
CAPACITY: _____ ELEVATOR CAR NUMBERS: _____ (IF APPLICABLE)
7. ACCESS IN HALL PLATES _____ ACCESS IN JAMB PLATE (3X5) _____
8. HALL STATION STYLE: FLUSH MOUNT _____ SURFACE MOUNT _____
INTERGRATED PI IN HALL STATION: EX-31 _____ EX-51 _____ OTHER _____
INTEGRATED PI FLOORS: 1,) _____ 2,) _____ 3,) _____ 4,) _____ 5,) _____ 6,) _____ 7,) _____ 8,) _____ 9,) _____ 10,) _____
9. ABOVE DOOR HALL PI: EX-51 _____ OTHER _____
FLUSH _____ SURFACE _____ WITH ARROWS _____ WITHOUT ARROWS _____
INTEGRATED PI FLOORS: 1,) _____ 2,) _____ 3,) _____ 4,) _____ 5,) _____ 6,) _____ 7,) _____ 8,) _____ 9,) _____ 10,) _____
10. CAR RIDING LANTERN WITH CHIME - QTY: _____ STANDARD _____ VANDAL RESISTANT _____
11. 24 HR EMERGENCY NUMBER: () _____ SHARED PHONE LINE? _____ YES _____ NO
GOOGLE VOICE NUMBER () _____

SPECIAL INSTRUCTIONS: _____



DOOR OPERATING EQUIPMENT ESTMATE/ORDER FORM

Customer _____
Requested by _____
Customer Address _____
Job Name _____

Phone _____
Fax _____
Job No. _____
Ship To _____

Date _____
Date reqd. _____
Estimate # _____
Purchase Order # _____

DOOR OPENING _____ X _____
WIDTH HEIGHT

Right Hand



S/S

Left Hand



3/SP

Center Parting



SS/CP

2SP/CP

New Installation

Modernization (provide survey sheets)
Advise Existing Door Equipment Mfg. _____

Comply with code

QTY PRODUCT

_____ OPERATOR (Includes Drive arm(s) & Gate Switch) _____ GATES WITCH ROLLER & ARM

_____ 230 DRIVE _____ 115V Drive (Closed Loop)

_____ Parameter Unit Hand Held

_____ ECI-895/1000 Specify Voltage _____

_____ OTHER OPERATOR MODEL _____ (Includes Drive Arm(s) & Gate Switch)
 220vdc motor 115vdc motor (MODL Only)

_____ CAR DOOR HANGER (Includes header, track, and Sheaves)

_____ GAL CLUTCH with zone lock without zone lock _____ RUNNING CLEARANCE

_____ ECI CLUTCH with zone lock without zone lock _____ SILL SPACING

_____ INFRARED CURTAIN Formula System-FCU47 Janus
 Plug & Play Nudging 3D With LED Lights

_____ HATCH DOOR HANGER (Includes tracks and Sheaves) () R.H. () L.H. () C.P.

_____ HALL DOOR CLOSER Spring (Sill linkage) Reel (spirator) S/S & C/P Doors only

_____ CAR DOOR CLOSER 2 SPEED (Sill linkage)

_____ INTERLOCK Ass'y (Includes Roller Release, & Beak) () R.H. () L.H. () C.P.
 ECI GAL

_____ EMERGENCY UNLOCKING KEY INT1H-0034N

_____ # of Landings _____ Car _____ of _____

_____ CLUTCH PLATE 8" X 16" _____ PICK UP PLATE 8" X 6"

_____ KEEPER PLATE 10 3/4" X 3 1/4" _____ ADJUSTABLE LOCK MOUNTING BRACKET (4C)

Cab Mfg: New Existing

Entrance Mfg: New Existing

Controller Mfg: New Existing



CED
 Long Beach, CA • Grand Prairie, TX • Columbia, MD
 (866) 233-3538

Replacement Door Program
 Genuine Columbia Elevator Products Inc. Doors

Doors are Universal for left and right hand, Cab and Hoistway, as such they are undrilled

Handing of doors determined by - Standing in hall which direction does the door close

Please Circle Required Opening size

Single Slide : Only Available for 36" x 84" or 42" x 84" openings

(Enter Required Quantity in Boxes Below)

		Left Hand		Right Hand			
		Cab	Hatch	Cab	Hatch		
	LH						RH
	Painted OFF WHITE (6070 Pearl)	<input type="checkbox"/>	<input type="checkbox"/>	<input type="checkbox"/>	<input type="checkbox"/>		
	Stainless Steel #4 (Brushed)	<input type="checkbox"/>	<input type="checkbox"/>	<input type="checkbox"/>	<input type="checkbox"/>		

Please Circle Required Opening size

Center Opening : Only Available for 42" x 84" or 48" x 84" openings

(Enter Required Quantity in Boxes Below)

		Left Hand		Right Hand			
		Cab	Hatch	Cab	Hatch		
	LH						RH
	Painted OFF WHITE (6070 Pearl)	<input type="checkbox"/>	<input type="checkbox"/>	<input type="checkbox"/>	<input type="checkbox"/>		
	Stainless Steel #4 (Brushed)	<input type="checkbox"/>	<input type="checkbox"/>	<input type="checkbox"/>	<input type="checkbox"/>		

Note: For Center Opening use the direction of the driven door when closing

Please Circle Required Opening size

Two Speed : Only Available for 42" x 84" or 48" x 84" openings

(Enter Required Quantity in Boxes Below)

		Left Hand		Right Hand			
		Cab	Hatch	Cab	Hatch		
	LH						RH
	Painted OFF WHITE (6070 Pearl)	<input type="checkbox"/>	<input type="checkbox"/>	<input type="checkbox"/>	<input type="checkbox"/>		
	Stainless Steel #4 (Brushed)	<input type="checkbox"/>	<input type="checkbox"/>	<input type="checkbox"/>	<input type="checkbox"/>		

Pump Unit Survey Form

Customer: _____

Job Name: _____

Contact: _____

Address: _____

Phone: _____

Fax #: _____

Floor Rise: _____

Capacity: _____

Car Weight: _____

Gross Weight: _____

Piston Size: _____

F.P.M.: _____

Existing HP: _____

Full Load: _____

Running P.S.I.: _____

Motor Voltage: _____

Valve Coil Voltage: _____

Oil Line Size: _____

Hand of Unit: _____

Machine Room: _____

Door Size: _____

Note: P.S.I.: _____ Valve: _____

GPM: _____ Pump: _____

HP: _____ Price: _____



3000 Walnut Avenue
Long Beach, CA 90807
Toll Free: (866) CED-ELEV
Fax: (562) 427-8429

Order Form

Questions? Answers at...
(866) CED-ELEV • (866) 233-3538
www.cedelevator.com



33

■ FAX ORDER FORM ■

BILL TO

SHIP TO

Ordered by

Date

Phone#

Fax#

P.O.#

Job#

Required Delivery Date

Shipped Via

Quantity	Part Number	Description	Unit Price*	Total
----------	-------------	-------------	-------------	-------

*CED will complete the price column and fax your order form back with confirmation of your order.

TOTAL

Special Instructions

Signature

**ORDER FORM MASTER
PLEASE USE
A PHOTOCOPY**

CED accepts Mastercard,
Visa and American Express



Questions? Answers at...
(866) CED-ELEV • (866) 233-3538
www.cedelevator.com



Questions? Answers at...
(866) CED-ELEV • (866) 233-3538
www.cedelevator.com

Order Form

BILL TO SHIP TO

Blank lines for billing and shipping information.

Ordered by Date

Phone# Fax#

P.O.# Job#

Required Delivery Date Shipped Via

Quantity Part Number Description Unit Price* Total

Main table with columns for Quantity, Part Number, Description, Unit Price*, and Total. Contains multiple blank rows for item entry.

*CED will complete the price column and fax your order form back with confirmation of your order. TOTAL

Special Instructions

Blank lines for special instructions.

Signature

Questions? Answers at...
(866) CED-ELEV • (866) 233-3538
www.cedelevator.com

CED accepts Mastercard, Visa and American Express



ORDER FORM MASTER PLEASE USE A PHOTOCOPY

Return Policy Important Information

In case of damage, shortage, and/or incorrect shipment

Breakage or Damage

Freight, Express or non-CED truck delivery

Note: According to the contract terms and conditions of the Carrier, the responsibility of the Shipper ends at the time and place of shipment. The Carrier then assumes full responsibility for the shipment.

1. Whenever possible, note the damaged items on the freight bill before signing. Notify the local agent of the transport company immediately.
2. Hold all damaged goods with container and packing for inspection of the examining agent. Do not return any damaged goods prior to inspection and authorization of the transport company.
3. File appropriate claim against transport company. Substantiate claim by examining agent's report. A certified copy of CED Elevator & Electrical invoice will be available upon request.
4. Contact CED Elevator & Electrical regarding your requirements for replacement material.

Federal Express/UPS shipments

1. Contact local FedEx or UPS office regarding damage and insurance claim.
2. Retain container and packing for inspection purposes.
3. Each FedEx/UPS office has a different method of handling claims and will advise you of their procedures.
4. Contact CED Elevator & Electrical regarding your requirements for replacement material.

Shortages

1. Check for pack slip notations; shortage may have been due to back order or split shipment.
2. Recheck package, particularly for small items. Ascertain that items were not removed by personnel prior to complete unpacking and checking.
3. Notify CED Elevator & Electrical immediately by fax; provide packing slip number and details of shortage.

Incorrect Shipment

1. If all material received does not correspond with your order, notify CED Elevator & Electrical immediately; provide packing slip number and details of problem with shipment.
2. Hold incorrect material until return shipping instructions are received.

Returns

Do not return any items, whether damaged, incorrect, or excess material until complete return shipping instructions are received from CED Elevator & Electrical!

Return for Credit Policy

1. Merchandise must have a "Return Authorization Number."
2. "Returns" must be identified by CED Elevator & Electrical invoice number or packing slip number.
3. No material can be accepted for return after 60 days from date of sale.
4. "Special" or modified material is not eligible for return.
5. Restocking charges, where applicable, will be deducted from credit memo.
6. All return material is subject to incoming inspection and must be in original carton.
7. Original carton shall not be used as shipping carton.
8. Acceptance of return material is at the sole discretion of CED Elevator & Electrical.

A

- Acrylic Signs 27.13-16
- ADA Phones 28.2-5
- Additive, Soft Start 9.17
- Alarm Bells & Brass Bells 12.6
- Anti-Rotation Device 31.9
- Aqueous Cleaners
 - All-Purpose Cleaner/Degreaser 16.6
 - Foaming Cleaner/Degreaser 16.6
 - Glass Cleaner 16.6
 - Grease Buster 16.6
- Auxiliary Contacts 3.2-8
 - Sprecher + Schuh 3.2-8

B

- Babbit Sockets & Accessories 31.9
- Ball Valves 17.6-7
- Barricade, Pedestrian 25.5
- Based LEDs 14.12
- Batteries
 - Alkaline 1.3
 - Rechargeable Alkaline 1.3
 - Cross Reference 1.4
 - Sealed Lead-Acid 1.2
- Bearing Press 4.7
- Bells, Alarm & Brass 12.6
- Black Pipe, Hydraulic 17.7
- Blocks
 - Rail Block/Clevis 10.6
 - Wire Rope Block 10.5
 - Wood Tackle Blocks 10.5
- Blowers & Exhaust Fans 6.2-3
- Boxes & Covers 5.11-12
- Braille Tags 27.2-8
- Bumper, Door 4.17
- Burnishing & Polishing Tools 9.13

C

- Cable Bands 31.7
- Cable Jacket Stripper 2.17
- Cable Oilers & Wicks 30.11
- Cable
 - Compensating Cable 2.11
 - Compensating Cable Installation Kits 2.13
 - Communications Shielded Pairs 2.7
 - Cutting Tools, Cable & Wire 2.17
 - Damping Devices 2.13
 - Hoistway 2.8-9
 - Hoistway Guard Systems 2.16
 - PhlexGrip Cable Hanging Support Bracket 2.13
 - Power, TEW & THHN 34.4
 - Product Specifications 2.2-12
 - Shielded Pair 2.10
 - Technical Information 2.12

- Traveling 2.2-7
- Calipers 30.11
- Capstan 10.3
- Car Lanterns 7.5-6
- Car Stations 7.4-6
- Car Top Inspection Station 12.2
- Certificate Frames 27.18
- Chain & Anchor Shackles 10.6
- Channel & Components 5.15
- Chimes 9.16
- Clamps
 - Rail 10.7
 - Roebling 31.7
 - Shortening 31.6
 - Wire Rope 10.5
- Cleaners/Degreasers
 - All-Purpose 16.7
 - Aqueous 16.6
 - Grease Buster 16.6
 - Foaming 16.6
 - Hand 16.5
 - Heavy Duty 16.5
 - Natural Degreaser 16.5
 - Precision Contact 16.7
- Clevises
 - Crosshead Clevis 10.6
 - Quick Release 10.6
 - Rail Block/Clevis 10.6
 - Rail Hoisting 10.7
- Climber, Wire Rope 10.2
- Compensating Cable 2.11
- Compensating Cable Kit 2.13
- Conduit Benders 30.10
- Connectors, Split-bolt 5.13
- Contact Assemblies (GAL) 4.3
- Contact Kits, Replacement 19.7-13
- Contactors (Section 3)
 - Auxiliary Contacts 3.9, 3.13
 - Cross Reference Table 3.21-22
 - Electronic Overloads 3.14, 3.25
 - Definite Purpose Heavy Duty-Class 40 3.19, 3.27
 - Solid State Overloads 3.11
 - Thermal Overloads 3.5, 3.14
 - 3-Pole AC 3.9, 3.23
 - 3-Pole AC Reversing 3.10, 3.14, 3.17, 3.25
 - 3-Pole AC Non-Reversing 3.2, 3.13, 3.16
 - 3-Pole DC 3.26
 - 4-Pole 3.4, 3.24
- Controllers 7.2-3
- Control Relays (Section 3)
- Convenience Box, Auxiliary 5.6
- Coolers, Tank 6.5-6
- Corrosion Inhibitors
 - Enamel Spray Paint, Rust Proof 16.4
 - Zinc Spray Coating 16.4

Counterweight Derailment System 25.6
 Coupling, Isolation 21.2
 Couplings, Hydraulic 17.2
 Crimping Tools 30.9
 Modular Plug, CATV 30.9
 Cutters, Cable 30.7
 Cush Clamps 5.15
 Cylinder Head ID Handbook 22.44
 Cylinder Heads, Packing Sets 22.2-33

D

Damping Devices 2.13
 Disconnect Switches 19.5
 Door
 Bumper, 4.17
 Astragal 9.13
 ECI Door Boards 4.18
 Edges (Infrared Curtain Protection) 7.9-10
 Fire Tabs 4.16
 Gibs 4.16
 Lock Wire 31.5
 Operator Replacement Parts (GAL) 4.3-7
 Operators (MAC) 4.13-14 (GAL) 4.2
 Pressure Gauge 32.5
 Pull Straps 4.19
 Replacement Rollers 4.8-12
 Restrictor 9.17
 Spirator 4.17
 Doors 7.7-8
 Drills
 Bits & Vari-Bits 30.4
 Driver 30.6
 Drip Rings 22.38
 Duct 32.2
 Dust Air Spray 16.7

E

Edges, Door 7.9-10
 Electrical Testers 29.2-3
 Emergency Lighting & Replacement Parts 15.2-3
 Emergency Power Supply (for Blowers) 6.3
 EMT
 Conduit Bodies 5.7
 Connectors & Couplings 5.8
 EMT-to-Flex Couplings 5.10
 Flexible Metal Fittings 5.10
 Tubing, Fittings, & Accessories 5.7
 Epoxy Putty 16.8

F

Fan Grills 6.4
 Fans, Elevator Cab 6.3
 Filter Cart, Portable 11.2
 Filters, Motor Generator 20.2-3

Filtration System, Portable 11.2
 Fire Alarm Control Panel 12.5
 Fire Service Nudging Device 12.7
 Fire Signs 27.9-15
 Fish Tapes 30.10
 Fittings, EMT 5.7
 Fittings, Liquid Tight 5.10
 Fittings, Pipe 17.3-5
 Fixtures 7.4-6
 Flexible Metal Conduit 5.10
 Floor Protection
 CleanMat®, DuraMask®, BuilderBoard®,
 CarpetMask®, FloorShield® 9.5-6
 Fuses
 Class CC 8.2
 Electronic 8.6-8
 One-Time 8.9
 Midget 8.3-4
 Fuse Reference Table 8.11-12
 Semiconductor 8.10
 Time-Delay 8.5

G

GAL Replacement Parts
 & Components 4.3-4.7
 Gauges, Pressure & Tension 29.5-6
 GFCI Devices
 Cord, 6ft. 25.3
 In-line 25.3
 Quad Box, Protected 25.3
 Trouble Light 25.3
 Gibs, Door 4.16
 Greases
 Ball & Roller Bearing Hi-Temp 16.2
 E.P. Polyurea 16.3
 Extreme Pressure 16.3
 General Purpose 16.3
 Hi-Temp Disc Brake/Wheel Bearing 16.2
 Multi-Purpose 16.3
 Grills, Fan 6.4
 Grips, Kellems 2.14-15
 Gutter 32.2

H

Hall Stations 7.5-6
 Hand Cleaner 16.5
 Hardware, Miscellaneous
 Connectors, Split-bolt 5.13
 Lugs, Mechanical & Compression 5.13
 Insulated Butt Splices 5.14
 Polaris Connectors 5.13
 ScotchLok® Components 5.14
 Screws & Fasteners 5.15
 Split-bolt Connectors 5.13
 Tabs, Forks & Rings 5.13

Hardware, Miscellaneous, cont.
 Ty-Raps 5.14
 Wire Marker Cards 5.14
 Wire Nuts 5.14
 Heat Exchanger, Oil-to-Air 6.5
 Heaters
 Elevator Cab 6.4
 Tank 6.4
 Hoisting Equipment
 Blocks 10.5-10.6
 Cable 2.8-9
 Cable Climber 10.2
 Clamps, Rail 10.2
 Blocks, Wire Rope 10.5
 Clevises 10.6-7
 Hoist, Electric Capstan 10.2
 Lifting & Pulling Machine 10.3
 Power Hoist System 10.3
 Rope, Twisted 10.4
 Shackles, Chain & Anchor 10.6
 Winch, Power 10.3
 Wire Rope Sling 10.4
 Hoistway Cable 2.8-9
 Hoistway Safety Netting 2.16, 25.4
 Hoistway Shield Systems 2.16, 25.4
 Hooks, Material 9.2
 Hydraulic Oil Additive 9.17
 Hydro Machine, Temporary 11.2
 Hydro Spider 11.3

I

Infrared Curtain Protection 17.9-10
 Insecticide, Wasp & Hornet 16.8
 Inserts, Rail 24.5
 Inserts, Wall 27.7
 Inspection Mirror 25.2
 Inspection Stations
 Car Top 12.2
 Emergency Light Combo 12.3
 Lights/Buzzers 12.4
 Replacement Parts 12.4
 Insulated Butt Splices 5.14
 Interlock Kits (GAL) 4.3-7
 Isolation Coupling 21.2
 Isolation Pad 21.2

J

Junction Boxes 5.11-12

K

Kellems Grips 2.14-15
 Key Boxes
 Fire 13.3

Replacement Locks, Keys & Boxes 13.3
 Key Keepers 13.2
 Keys, Door 13.2
 Key Switches 9.7-9
 Knockout Punches, Kits & Plugs 5.12

L

Ladders, Pit 9.3
 Custom Pit 9.3
 Stepladders 9.4
 Lamps
 Flood, Reflector 14.2
 Fluorescent 14.2
 Incandescent 14.9-10
 Miniature 14.3-11
 Neon 14.11
 Technical Data (Minature) 14.3-4
 Lead Wire & Seal Press 29.5
 LEDs 14.2
 Lighting Fixtures
 Emergency & Replacement Parts 15.2-3
 Strip Fluorescent 15.3
 Light Kit, Halo 11.3
 Lights
 Bulbs, Guards, Specialty 5.2
 Flashlights 5.2
 Limit Switches 5.4-5
 Liquid Tight Fitting 5.10
 Lockout/Tagout Devices 19.6
 Lugs, Mechanical & Compression 5.13

M

MAC Door Operator Service Parts 4.13-15
 Material Hooks 9.2
 Melting Pot 31.9
 Mesh 2.16, 25.4
 Metal Boxes & Covers 5.11-12
 Motor Generator Filters 20.2-3
 Motor Starters, Solid State
 Soft Start 19.2-4
 Nordic 3.16-20
 Motors, Elevator
 Submersible, Belt Drive, DC Door 18.2
 Muffler Isolation Coupling & Pad 22.2
 Mufflers 22.2
 Multimeters, Digital 29.2-3

N

Nudging Device 12.7

O

- Oil Absorbent Pit Pads 9.2
- Oil Cooler 6.5-6.6
- Oil, Hydraulic Additive 19.7
- Orange Stick 9.2
- Overloads
 - Electronic 3.5, 3.25
 - Thermal 3.14

P

- Packing & Seals 22.2-37
- Packing Box Worksheets 22.39
- Packing Replacement Kit 22.41
- Paint, Spray 16.4
- Pearlweave Hoistway Safety Netting 25.4
- Peelle Parts Guide 23.5-18
 - By Category 23.2
 - By Year 23.2-3
- Pendant Stations 5.3
- Phase Monitors 3.36
- Phones, ADA 28.2-5
- Piano Wire 24.3
- Pick-up Tools 30.1-11
- Pipe Couplings, Grooved
 - Caps & Nipples 17.4
 - Elbows, Tees and Crosses 17.3
 - Reducers, Concentric/Eccentric 17.5
 - Reducer, Threaded 17.4
 - Rigid & Flexible 17.2
 - Swaged Nipples 17.4
 - Tees, Reducing 17.5
- Pipe Joint Compound 11.3
- Pipe Nipples, Steel 17.7
- Pit Ladders 9.3
- Pit Pads 9.2
- Pit Switches, Outlets & Work Light 5.6
- Plumb Bob, Adjustable 11.3
- Plumb Line
 - Clamps 24.2
 - Gauges 24.3
 - Tensioner 24.3
- Polishing, Burnishing Tools 9.13
- Power Cable, TEW & THHN 31.4
- Pull Straps, Door 4.19
- Pumps, Scavenger 26.2
- Putty, Epoxy 16.8

R

- Rail
 - Alignment System, Laser 24.4
 - Block/Clevis 10.6
 - Brackets, Extensions & Clips 24.6

- Clamps 10.7
- File, Holder, Handle 24.5
- Gauge, Oilers, Shims 24.5
- Inserts 24.7

Reeving Splices 31.6

Relays

- Bases 3.34
- Control (ABB & Telemecanique) 3.23-27, 3.9-12, 3.15, 3.18
- Cross Reference Info 3.29-30
- General Purpose
 - OP (Open Power) 3.28
 - IC (Ice Cube) 3.30
 - GPM (Miniature) 3.31
 - GPO (Octal Base) 3.33
 - Blade Base 3.32
- Numbering System
- Overload
- Special Purpose 3.35

Ring & String 25.6

Roebbling Clamp 31.7

Rollers

- Door 4.8-12

Rope Grips 31.6

Rope, Polyester 10.4

Rupture Valves 17.7

S

Safety

- Glasses 25.2
- Gloves 25.2
- Handbook 25.2
- Mirrors 25.2
- Netting 25.4
- Switches, Heavy Duty 19.6
- Square Mesh Safety Cloth 2.10

Saws

- Blades, Arbors 30.2
- Hole Saw Kits 30.2-3

Scavenger Pumps 26.2

ScotchLok® Components 5.14

Screws & Fasteners 5.15

Sealant/Adhesive, Silicone 16.8

Seismic Switch 25.6

Selector Tape Guide 9.17

Shackles, Chain & Anchor 10.6

Shortening Clamp 31.6

Signs, Acrylic & Screen Printed 27.9-17

Signs, Die Cast 27.2-7

Signs, Metal Stamped 27.8

Silencers (MEI) 21.3

Smoke Detector 12.5

Smoke Test® 16.8

Snake Eye Driver Kit, Bits & Screws 30.6

Sockets, Wedge & Babbit 31.9

Soft Start Additive 9.17
 Soft Starters 3.6
 Spirators 4.17
 Split-bolt Connectors 5.13
 Springs 31.9
 Starters, Motor
 Solid State 3.20, 19.1-4
 Strip Light 15.3
 String Lights 5.2
 Strippers, Cable 30.8
 Struts 5.15
 Submersible Motors 18.1
 Swayless Devices 2.11
 Switches
 Bussman Power Module 19.5
 Heavy Duty Safety 19.6
 Limit 5.5
 Pit, Outlets & Work Light 5.6

T

2:1 Rope Change Tooling 31.10
 Tabs, Forks & Rings 5.13
 Tachometers 29.5
 Tank Heaters & Coolers 6.5-6
 Tapes, Friction, Rubber, Electrical, All-Weather 9.6
 Telephone Cabinets 28.5
 Telephone Replacement Parts
 & Accessories 28.6
 Telephones, ADA
 Building Powered AC 28.2
 Phone Line Powered 28.3
 Test Weight Carts 29.6
 Testers, Electrical 29.4
 Timers
 Socket Mounted, Solid State & Rail Mount 3.37
 Traveling Cable 2.2-7
 Trough 32.2
 Ty-Raps 5.14

V

Valve, Ball 17.6-7
 Valve, Rupture 17.7
 Victaulic Fittings 17.3-5

W

Wall Panel Splines, Aluminum 9.2
 Wedge Sockets 31.9
 Wipers 4.6
 Winch, Power 10.3

Wire
 Door Lock 31.5
 Seizing 31.6
 Wire Cloth, Square Mesh 3.16, 25.4
 Wire, Copper, Power, TEW, THHN 31.4
 Wire Hookup 31.4-5
 Wire Marker Cards 5.14
 Wire Mesh Grips (Kellems) 2.14-15
 Wire Nuts 5.14
 Wire Rope 31.2-3
 Cable Bands 31.7
 Clips 31.7
 Cutters 31.8
 Grips 31.6
 Oil (Wire Rope Oil) 16.2
 Roebling Clamp 31.7
 Sling, Wire Rope 10.4
 Tags 31.2
 Tension Gauge 29.5
 Wedge Sockets 31.9
 Wire Seals, Lead 29.5
 Wireway
 45° Elbow Assembly 32.4
 90° Elbow Assembly 32.3
 Connector 32.2
 Crossover Assembly 32.4
 Duct 32.2
 End Cap/Reducer 32.5
 Hatch Duct Mounting Kit 32.6
 Insulated Bushing 32.5
 Reducer 32.5
 Tee Assembly 32.5
 Wire Support Kit 32.6

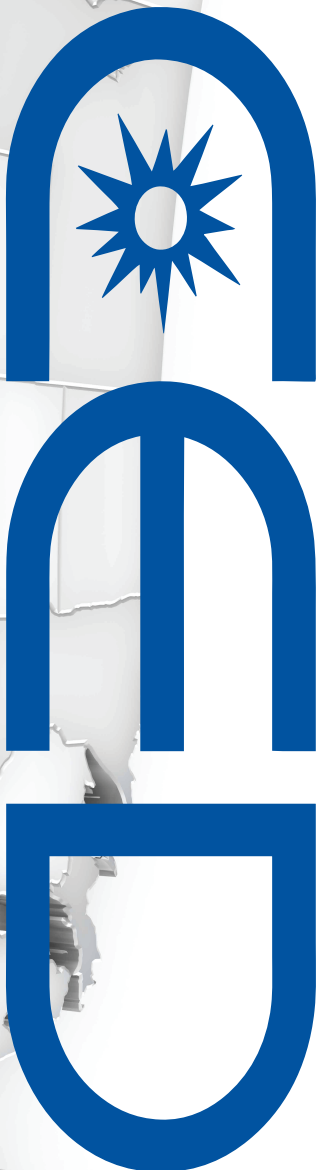

ELEVATOR & ELECTRICAL

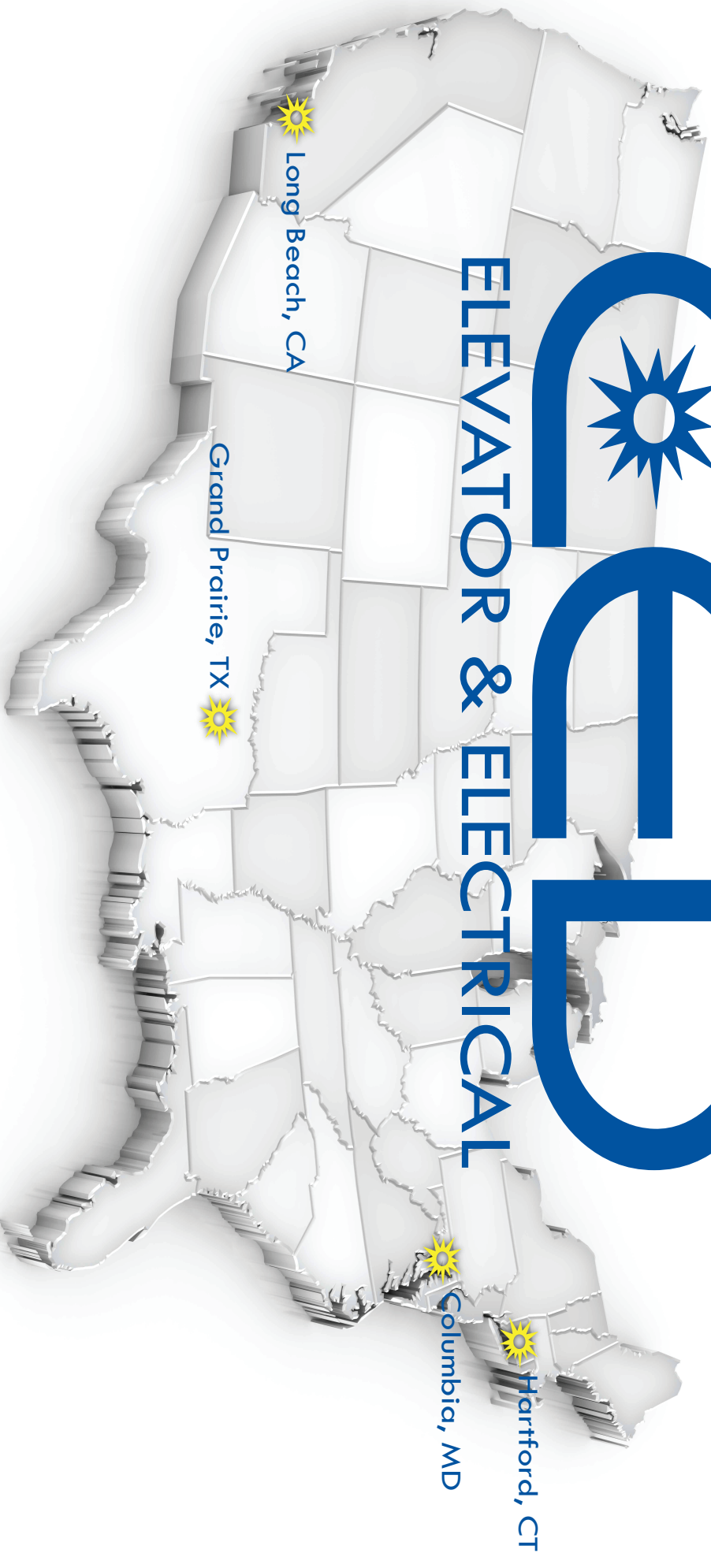

Long Beach, CA

Grand Prairie, TX

Columbia, MD

Hartford, CT

EXPANDING TO SERVE YOUR NEEDS

Long Beach/

Grand Prairie/Columbia

Hartford

866-253-2915

866-CED-ELEV

(233-3538)

